



Fully Integrated, Yet Flexible

PKvalve



PK valve

Fully Integrated, Yet Flexible

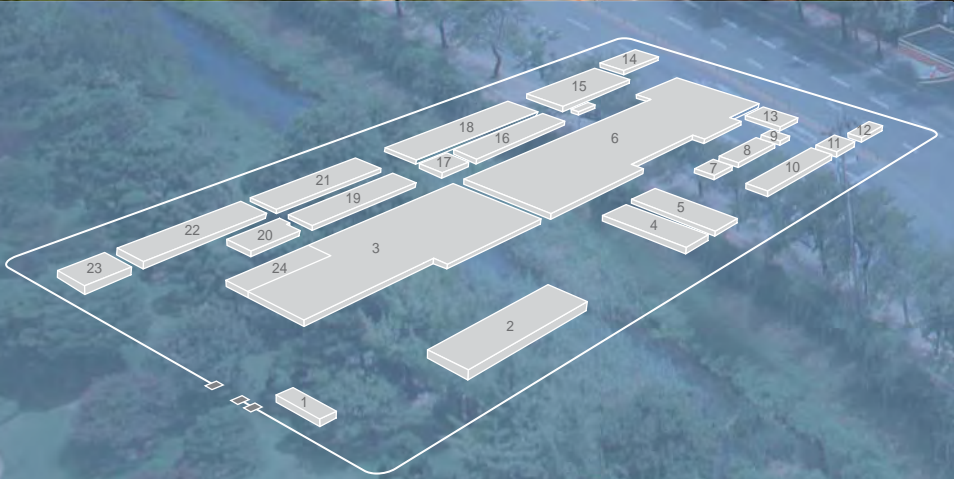

- 01. Entrance, Lounge
- 02. Main Office
- 03. Machinery Shop ①, Test Shop ①, Auditorium
- 04. Cryogenic Test Shop
- 05. Machinery Shop ②
- 06. Foundry Shop, Molding Shop, Heat Treatment Furnace, Test Shop ②
- 07. Foundry Office
- 08. Material R&D Center
- 09. Laboratory
- 10. Pattern Shop
- 11. Facility Maintenance Office
- 12. After Sales Service Shop
- 13. Lounge
- 14. Pattern Warehouse ①
- 15. Painting Shop
- 16. Casting Warehouse
- 17. Health Clinic
- 18. Painting Shop
- 19. Test Shop ③
- 20. R&D Center
- 21. Packaging Shop
- 22. Production Warehouse ①
- 23. Office ③, Cafeteria, Production Warehouse ②
- 24. Receiving Inspection Shop





CEO GREETING

All of our passion and energies have been committed to the development and supply of high quality valves and related services for more than 60 years, and during that time we have taken a leading role in the advancement of designs, technology, and service. In the rapidly changing world of today and tomorrow, PK Valve will step up to the challenges and lead our industry.

We are responsible for the quality and impact of our products and services on the industrial community and on our environment. As we continue to serve industries such as traditional power generation, nuclear power, oil & gas, shipbuilding, semiconductor, aerospace, marine industries, and others, we will remain committed and disciplined in meeting our responsibilities while leading our industry.



President
Hern-Gun Park

MANAGEMENT POLICY



On the basis of "Base on Reliability" as a fundamental management philosophy, all employees at PK Valve Co., Ltd. respect human life and worker's health care before all production activities, provide satisfactory products and services that meet the requirements of customers by means of management activities in harmony with environment and continuing technological development and quality innovations, and further make every effort to fulfill our social responsibilities and obligations with the realization of human happiness as our top priority, including the policies specified below.

- Recognize the Safety, Health, Environment & Quality (SHEQ) management as key factors in accomplishing our continuous stability and growth. we also comply with all legal and regulatory requirements, other applicable requirements as agreed and internal regulations that relate to safety, health, environment, and quality aspects.
- Improve and upgrade management system continuously through process improvement and technological development so that all the factors impeding safety, health, environment, and quality activities can be minimized.
- Establish and implement the management objectives and targets to accomplish our SHEQ management policy, and review and improve the continuing suitability of the management policy and system.
- Give careful consideration to safety, health, environment, and quality over the whole process ranging from product development, design, production, servicing, and disposal.
- Make every effort to prevent accidents by taking precautions to eliminate harmful and dangerous factors involving safety, health, and environment activities, and where an accident occur, take a proper measure to minimize the damage.
- Do our best to earn customer's trust and love by grasping accurately the quality requirements of customer and furnishing the best quality products that always satisfy customer's expectations and requests.
- Continuously give training to all PK Valve employees and other representatives who perform safety, health, environment, and quality related activities to inspire awareness and induce active participation.



QUALITY APPROVAL

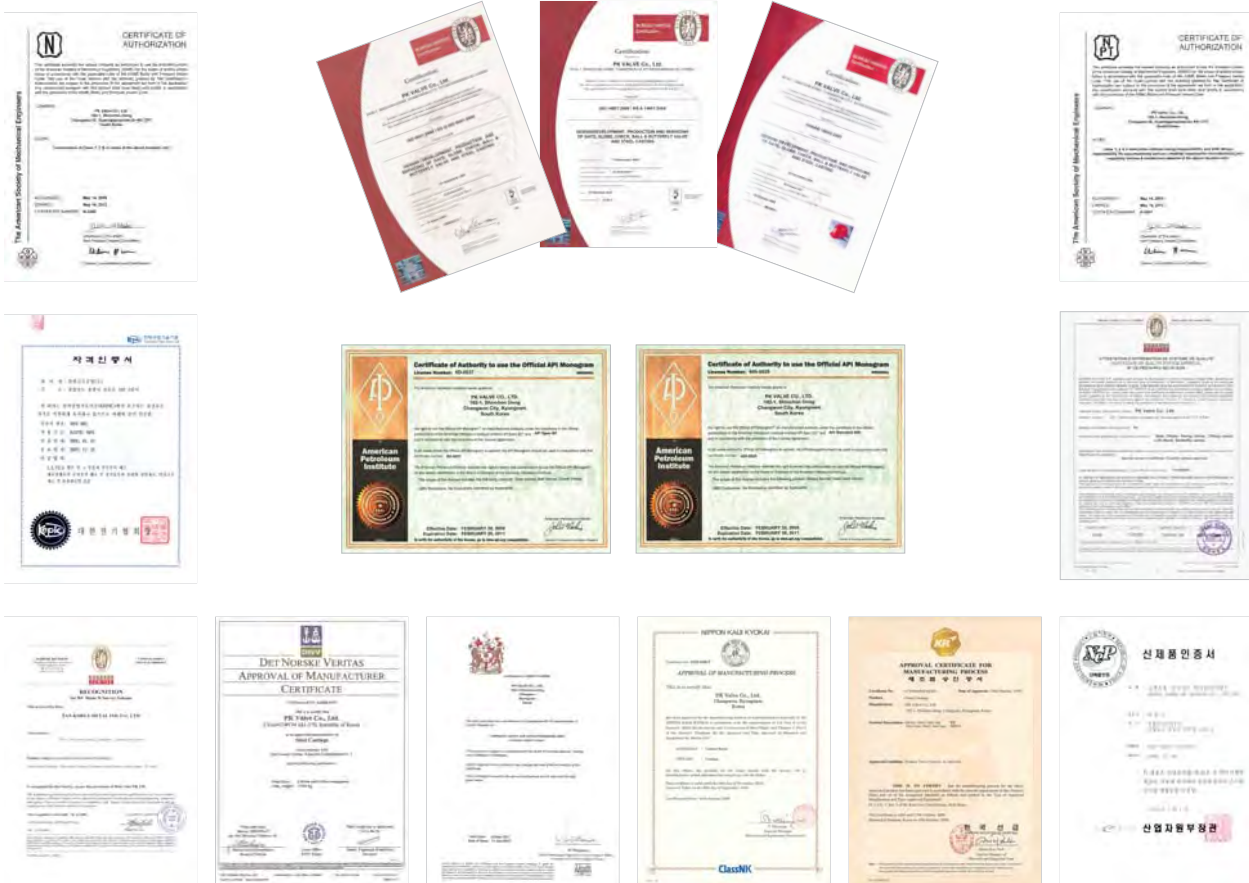

1. ASME-N (ASME) | May. 2009
2. ASME-NPT (ASME) | May. 2009
3. ISO 9001 / BVQI (Bureau Veritas Quality International) Management System | Sep. 1993
4. ISO 14001 / BVQI (Bureau Veritas Quality International) Management System | Nov. 2005
5. OHSAS 18001 / BVQI (Bureau Veritas Quality International) Management System | Nov. 2005
6. KEPIC (Korea Electric Power Industry Code) MN | Aug. 1998
7. CE(Community of Europe) PED 97/23/EC | Jul. 2001
8. API (American Petroleum Institute) 6D | Mar. 1978
9. API (American Petroleum Institute) 600 | Nov. 2005
10. BV (Bureau Veritas) Steel Casting | Apr. 1986
11. DNV (Det Norske Veritas) Steel Casting | Feb. 1983
12. LR (Lloyd's Register of shipping) Steel Casting | Oct. 1980
13. NK (Nippon Kaiji KyoKai) Steel Casting | Nov. 1981
14. KR (Korean Register of Shipping) Steel Casting | Oct. 1978
15. NEP (New Excellent Product) | Jan. 2006

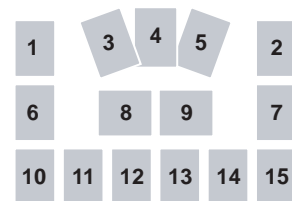

COMPANY HISTORY

- 1946** • Established Busan Pokum Ind. Company in Busan, Korea
- 1968** • Reorganized Busan Pokum Ind. Co., Ltd.

- 1971** • Obtained "KS" (Korean Industrial Standard) mark for Bronze & Cast Iron Valves / 5 Items (B2301, B2303, B2332, B2351, B2353)
- 1974** • Removed all facilities and factory to Changwon Industrial Complex (Current Location)
- 1975** • Obtained "KS" mark for Cast Steel & Marine Valves / 10 Items (B2361, B2363, B2365, B2367, V7311, V7313, V7314, V7323, V7324)
- 1978** • Approved Steel Valves Manufacturer by API (American Petroleum Institute) / API 6D Pipe Line Valves (Gate, Check, Ball, Plug)
 - Approved Carbon Steel & Stainless Steel Castings Manufacturer by KR (Korean Register of Shipping)
- 1979** • Expanded laboratory by installing SPECTROMETER and other equipment
 - Obtained "KS" mark for Cast Bronze Valves / 2 Items (B2311, B2313)

- 1980** • Renamed to Pan-Korea Metal Ind.Co., Ltd.
 - Approved Steel Casting Manufacturer by LR (Lloyd's Register of Shipping)
- 1981** • Designated as specialized installation of Power plant by Ministry of Commerce and Industry, Republic of Korea
 - Approved Steel Casting Manufacturer by NK (Nippon Kaiji Kyokai) / Licence No.81-49
- 1983** • Approved Steel Casting Manufacturer by DNV (Det Norske Veritas)
- 1985** • Developed Cryogenic Valves
- 1986** • Listed as specialized installation of power plant at KHIC (Korea Heavy Industries & Construction Co., Ltd.)/ List No.86-020
 - Affiliated as member of KAIF (Korea Atomic Industrial Forum)
 - Obtained Certificate of Manufacturer for Emergency Shutoff Ball Valve by Government
 - Approved Steel Castings Manufacturer by BV (Bureau Veritas)
- 1987** • Approved Fire Safe Ball Valves by AMTECH / API 607
 - Developed Pressure Seal Type Valves for high pressure and high temperature
 - Obtained Type Approval of Fire Safe Ball Valves by DNV
- 1988** • Listed as a manufacturer for installation of nuclear power plant at KEPCO (Korea Electric Power Corporation) / Non-Safety Class ANSI B31.1 Valves / Licence No.6
 - Obtained certificate of manufacturer for Nuclear Valve by Ministry of Science and Technology, Republic of Korea
 - Listed as manufacturer of Cryogenic Valve in KGC (Korea Gas Corporation) / List No.88-05

- 1989** • Listed as a manufacturer for installation of nuclear power plant at KEPCO / Safety Class ASME III Valves
 - Listed as a manufacturer for installation of thermal & hydroelectric power plant at KEPCO

- 1992** • Listed as a manufacturer for installation of nuclear power plant at KEPCO / ANSI B31.1 Motor Operated Valve
- 1993** • Listed as a manufacturer for installation of nuclear power plant at KEPCO / ANSI III Motor Operated Valve
 - Obtained ISO 9001 certificate by BVQI (Bureau Veritas Quality International)
- 1994** • Approved API 600, API 603 & ASME / ANSI B16.34 Manufacturer by Mobil Research Development Corp
- 1996** • Developed Bellows Seal Gate & Globe valve
 - Developed Metal Seat Ball valve
 - Developed Wafer Tilting Check valve
 - Started Low Fugitive Emission test
- 1997** • Obtained Quality Assurance Qualification certificate by KEPIC
- 1998** • Obtained TUV certificate by TUV Rheinland
 - Obtained EM (Excellent Machine, Mechanism and Material) mark for High-Pressure Metal Seat Tilting Check valve
- 1999** • Developed Low Emission Packing for valve
 - Developed Super Duplex Stainless Steel for casting

- 2000** • Developed Triple Offset Butterfly Valve
- 2001** • Selected as INNO-BIZ
 - Obtained CE (Community of Europe PED 97/23/EC) certificate
 - Obtained EM mark for high pressure Triple Offset Butterfly Valve
- 2002** • Listed approved valve manufacturer by ExxonMobil
 - Listed approved valve manufacturer by Shell Chemical
 - Obtained EM mark for Triple Offset Metal Seat Butterfly Valve

CONTENTS

1. CAST STEEL VALVES

- GATE VALVES
- GLOBE VALVES
- SWING CHECK VALVES
- TILTING DISC CHECK VALVES
- DUAL PLATE CHECK VALVES

2. PRESSURE SEAL VALVES

- GATE VALVES
- GLOBE VALVES
- SWING CHECK VALVES
- TILTING DISC CHECK VALVES

3. PARALLEL SLIDE GATE VALVES

- BOLTED BONNET TYPE
- PRESSURE SEAL BONNET TYPE

4. STAINLESS STEEL VALVES

- GATE VALVES
- GLOBE VALVES
- SWING CHECK VALVES

5. CRYOGENIC VALVES

- GATE VALVES
- GLOBE VALVES
- SWING CHECK VALVES
- BUTTERFLY VALVES

6. BELLOWS SEAL VALVES

- GATE VALVES
- GLOBE VALVES

7. BUTTERFLY VALVES

- TRIPLE OFFSET TYPE
- DOUBLE ECCENTRIC TYPE
- CONCENTRIC TYPE

8. BALL VALVES

- FLOATING BALL
- TRUNNION BALL

9. FORGED STEEL VALVES

- GATE VALVES
- GLOBE VALVES
- LIFT CHECK VALVES
- SWING CHECK VALVES

10. ACCESSORY

- 2003**
 - Listed approved valve manufacturer by Saudi Aramco
 - Joined NSSS(Nuclear Steam Supply System) for Motor Operated Valve as one of the Vendors
- 2005**
 - Obtained ISO 14001, OHSAS 18001 by BVQI
- 2006**
 - Obtained NEP Mark for Cryogenic Metal Seated Butterfly Valve
 - Changed company name and logo to PK Valve Co.,Ltd. & 
- 2007**
 - Honored with "U\$ 70 Millions Achievement Award" at the 44th Annual Trade Day
 - Awarded by Government for " New Technology Practicality Promotion "
 - Obtained the Patent of Live-loading Seat Supporting for Cryogenic Butterfly Valves
 - Carried out the QME-1 test for NSSS (Nuclear Steam Supply System) By Wyle Laboratories
- 2008**
 - Appointed as excellent company for productivity improvement by Government
- 2009**
 - Obtained ASME "N" & "NPT" certificates
- 2010**
 - Award the biggest 88" valve
 - Constructed a new Production Office
- 2011**
 - Established Material R & D Center
 - Built a new R & BD Center



PK FIGURE NUMBER SYSTEM

Example

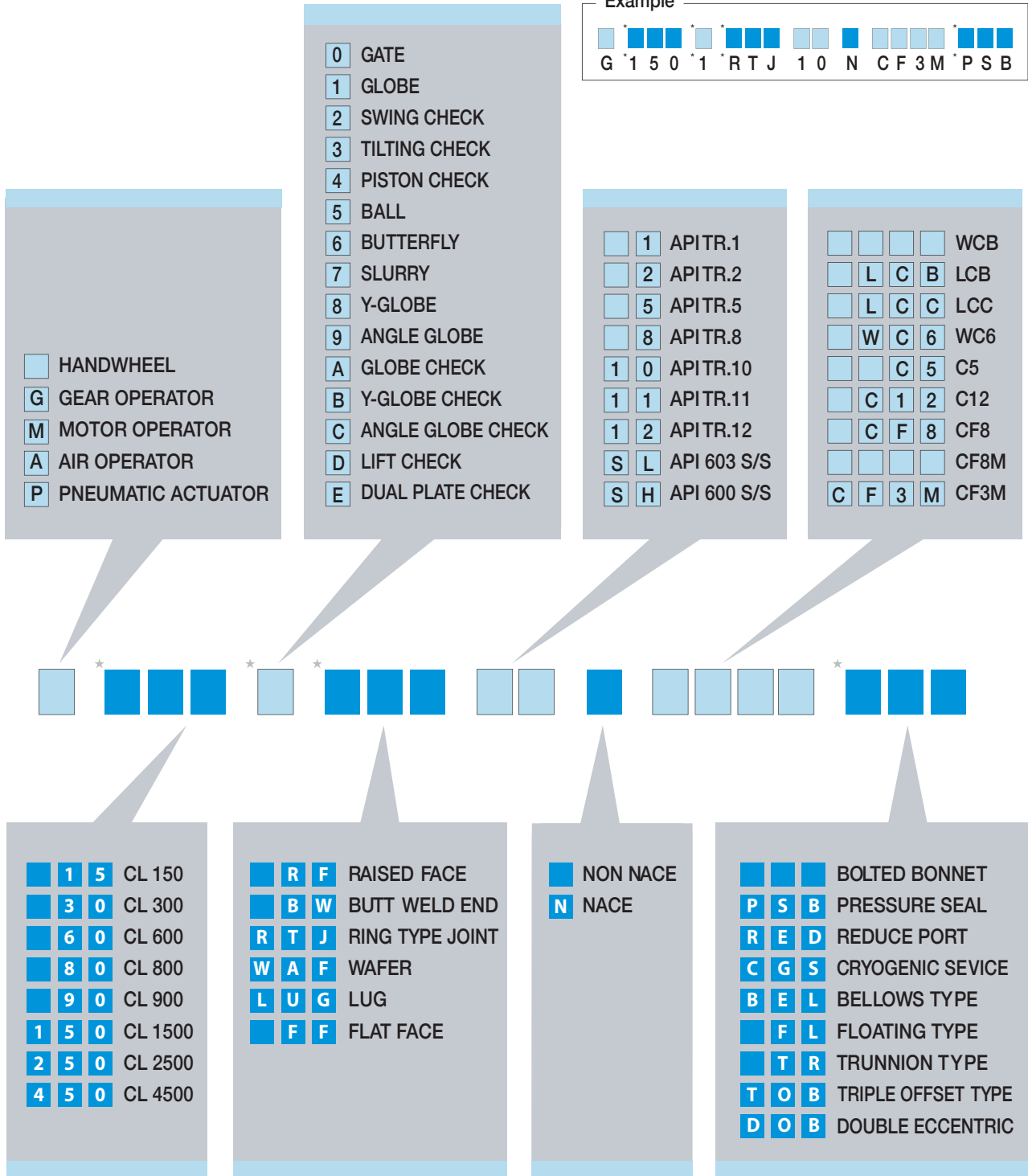
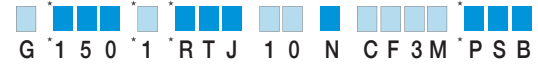

CAST STEEL VALVES

- *GATE VALVES*
- *GLOBE VALVES*
- *SWING CHECK VALVES*
- *TILTING DISC CHECK VALVES*
- *DUAL PLATE CHECK VALVES*



CAST STEEL VALVES

SERVICE FEATURES

- Several trim combinations available for various services.
- Straight-through port design offering a good flow with minimum frictional loss and turbulence.
- Cast steel valves suitable for works demanding strength, shock resistance, elongation and heat resistance.
- Bottom seating of seat rings ground accurately for maximum strength and tightness(globe).
- Bypass mounting to equalize pressures.
- Normal yoke bushing furnished with ductility resistant to high melting point of above 2200°F.
- Level and weight available to accelerate/decelerate disc closing (swing check).
- Designed for maximum flow with minimum pressure drop if possible.
- Precision-ground seating surfaces and revolving disc providing a long life.

In the refineries, power plants, utilities and petrochemical/chemical process industries, PK cast steel valves have been regarded as of great importance about their excellent performance and reliability.

By discriminatory blending of carefully selected materials combined with sound design and precision machining/assembly under strict quality controls, PK steel valves have gained general and wide acceptance. The products are manufactured in accordance with ASTM, ANSI, or other international standards.

CAST STEEL VALVES PRODUCTION RANGE

UNIT : NPS

Type \ Class	150	300	600	900	1500
GATE	2-96	2-80	2-48	2-48	2-24
GLOBE	2-24	2-24	2-24	2-24	2-24
SWING CHECK	2-56	2-48	2-48	2-36	2-24
TILTING CHECK	2-48	2-48	2-48	2-36	2-24
Y-GLOBE	2-24	2-24	2-24	2-24	2-24
ANGLE GLOBE	2-24	2-24	2-24	2-24	2-24

PRODUCTION MATERIALS

- Carbon Steel : ASTM A216-WCB or Equivalent
- Alloy Steel : ASTM A217-WC6, WC9, C5, C12, C12A or Equivalent
- Stainless Steel : ASTM A351-CF8, CF8M, CF3, CF3M, CN7M, or Equivalent
- Duplex Stainless Steel : ASTM A995-1A, 2A, 4A, 5A or Equivalent
- Special Alloy Steel : Inconel 625, Incoloy 825, Hastelloy C, Monel, AL-BRONZE
- ASME SA designation material(e.g ASME SA217-WC6)

GATE VALVES

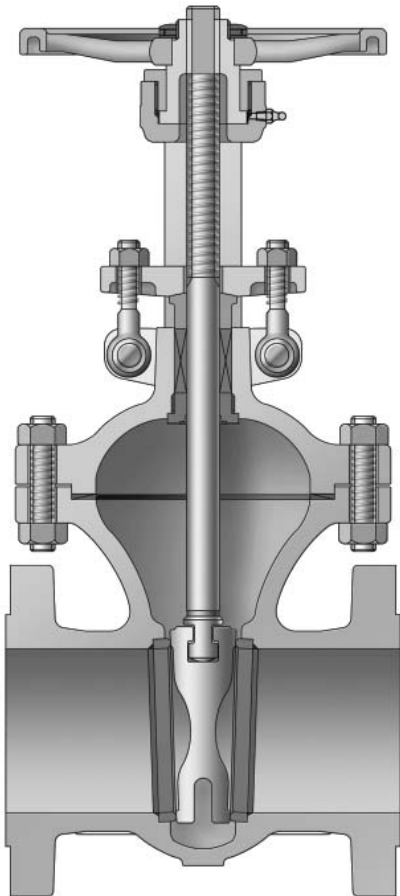

FUNCTION

Gate valve is characterized by a sliding wedge which is moved by actuator perpendicular to the flow direction. There are a variety of valve sizes and types. The valve is used primarily as a stop valve to open or close fully. Normally it works for slurries, viscous fluid, etc., but not for throttling. The gate valve usually has a minimum pressure drop in full open and a tight seal in full close, and therefore there is little possibility that contaminants may enter the valve.

BODY AND BONNET

The body and bonnet is designed to achieve most uniform distribution of stress on all sides and minimum turbulence and resistance to flow. The bonnet on valve is equipped with back seat ring up to 12" for Class 150 & 300 and up to 10" for Class 600 or higher. The yoke is integrated with bonnet.

BODY-BONNET JOINT

Body-bonnet joint of gate valve is machined as follows:

Class 150 Plain faced

Class 300 and higher class Male and female

We can supply any kinds of gasket as required by customer.

WEDGE

The valve is normally supplied with a one-piece flexible wedge of which the cross section is a tapered H shape.

All wedges are fully guided. The flexible wedge is cast or machined with circumferential grooves to allow the seating faces to move independently and adjust the movement of body seat.

It is used where the line load or thermal expansion of system may distort the seating face of valve, and especially useful to prevent sticking that may happen in case the valve is closed at a hot temperature and opened at a cold temperature.

Ideally the wedge is suitable for steam and other high temperature service.

SEAT RING

The seat ring as a welded-in type is designed to prevent any turbulence and damage by corrosion. It is forged or rolled type into one piece for all dimensions, heat treated to obtain the desired surface hardness, and cleaned thoroughly before assembling.

STEM

The stem connection to the wedge shall have an integrated tee head (without welding) and is rectified in the packing area to ensure a long life and perfect tightness. Through experiments, we have calculated and checked the connections between stem and wedge not to disengage the stem from wedge while gate valve is working.

The strength of stem and wedge connections is stronger than that of stem alone at the root of thread.

PACKING

The packing size is designed to secure maximum tightness along the stem, and the standard packing is a non-asbestos type. We can supply any kinds of packing as required by customer.

YOKE SLEEVE

The yoke sleeve is designed to be able to be disassembled without discounting bonnet and stem, and provided with ball bearing of 14" or over for Class 150 ~ 300 valves, 6" or over for Class 600, and 2" or over for Class 900 ~ 1500.

GLAND

The gland is made of two pieces. Packing gland is in contact with the packing which is connected to gland flange through a spherical joint. Particular design permits a correct pressure on the packing without any damage to stem due to friction or corrosion.

STUFFING BOX

The stuffing box gives maximum packing stem seal.

Lantern ring and grease injector shall be furnished only if specified on the purchase order.

HAND WHEELS

Hand wheels are designed for easy operation. With gearing, motor actuator or cylinder actuator, it is also available for more difficult services.

BOLTS AND NUTS

Bolts and nuts are made from four different types of steel materials in conformity with the ASTM specification:

1) A307 Grade B : It has a minimum tensile strength of 55,000 pounds per square inch (3870kg/mm²).

The nuts normally used with machine bolts are a hot pressed steel conforming to ASTM specification A307, which is usually applied to hinge bolts and nuts.

2) A193 Grade B7/B16 : It usually retains the strength well at an elevated temperature and offers higher resistance to creep than any other high grade steel used as bolting materials. This steel is regularly used in bonnet bolts.

3) A194 Grade 2H/4 : The nuts of this grade shall be re-heated above the critical range of steel, quenched in a suitable medium, and then tempered at a temperature not less than 850°F(455°C). This steel is regularly used in bonnet nuts.

4) Carbon steel : It is used in hand wheel nuts, set screws, or nipples.

END CONNECTIONS

In our standard production of valves, the flange ends(RF.FF) and the face to face dimensions conform to ANSI B16.5 and ASME B16.10, respectively, and they have a raised face serrated finish type or other finish type as requested.

For butt-welded ends (B.W.), of which the end to end dimension conforms to ASME B16.10, customer must specify the schedule type required, pipe class, or bore diameter.

Ring type joint flanged ends (R.T.J) conform to ASME B16.5 and the end to end dimension follows ASME B16.10. The other special end connections may be supplied as required by customer.

GEAR OPERATED VALVES

Valves can be supplied with gear operators.

MOTOR OPERATED VALVES

Valves can be supplied with actuators, either electric or pneumatic, according to customer's requirements.

ACCESSORIES

We can supply a valve fitted with accessories such as bypass, locking device, chain wheel, extension stem, etc. For more details, refer to the Accessories column.

PACKING AND GASKET MATERIALS

Packing material supplied in standard valves is non-asbestos graphite, with braided graphite rings and die-formed rings configured to provide reliable and long-lasting performance. Braided rings are coated with zinc dust to inhibit corrosion.

Dieformed rings are 98% carbon(minimum)and have maximum 50PPM chloride 550PPM sulfur content.

For standard valves, gasket materials are as follows;

Class 150 - graphite sheet type with 304 stainless steel tanged insert. (1.6mm minimum overall thickness)

Class 300 - spiral wound 304 stainless steel and graphite.

Class 600 - same as class 300 or 900

Class 900 and 1500 - Ring type joint

SEAL AREA DESIGN

Cast steel valves are designed and manufactured to satisfy strict requirements in order to prevent external leakage and to meet fugitive emission requirements of most customers.

Stuffing box finishes of 63 to 125 RMS, stem finishes of 16 to 32 RMS, control of straightness and concentricity of stems, and controlled diametrical clearances between stem and gland, stem and backseat, and gland and stuffing box, all combine to guarantee consistent performance of stem seals.

Gasket surfaces between bodies and bonnets are strictly controlled to finishes of 32 to 63 AARH. When combined with engineered bolting design, quality materials and strict assembly procedures, these finishes guarantee consistent sealing in gasket areas.

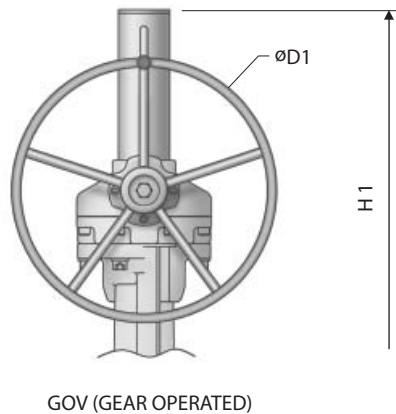
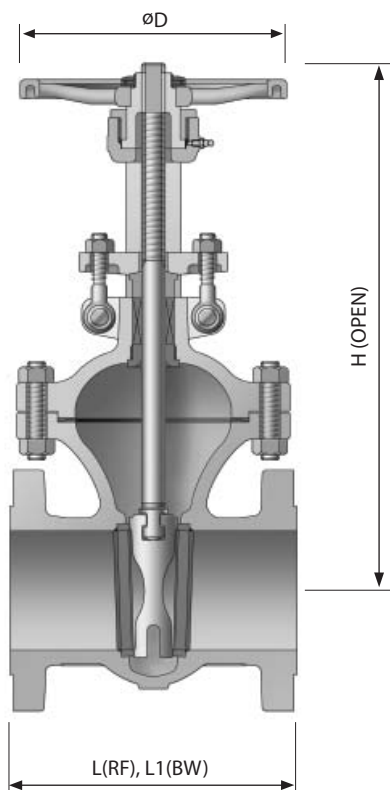

END CONNECTION

- R.F FLANGED ENDS TO ASME B16.5
- B.W. ENDS TO ASME B16.25
- R.T.J FLANGED ENDS TO ASME B16.5
- SIZE 26" AND LARGER, FLANGED ENDS ACCORDING TO ASME B16.47 SER.A OR SER.B

STANDARD MATERIAL SPECIFICATIONS

NO	PART NAME	MATERIAL		
1	BODY	A216 - WCB	A216 - WCB	A351 - CF8M
2	DISC	A217 - CA15	A351 - CF8M	A351 - CF8M
3	SEAT	13 Cr. / STELLITE #6	SS 316	METAL TO METAL
4	HINGE PIN	A276 - 410	A276 - 316	A276 - 316
5	STOP PIN	A276 - 410	A276 - 316	A276 - 316
6	SPRING	INCONEL X-750 / SS 316		
7	GUIDE	A576 - 1020	A576 - 1020	A276 - 316
8	WASHER	A276 - 304	A276 - 316	A276 - 316
9	SET SCREW	A193 - B7	A193 - B7	A193 B8M
10	EYE BOLT	SS 400 or SS 304		
11	HINGE BOLT	A307 - B	A307 - B	A193 - B8
12	HINGE NUT	A194 - 2H	A194 - 2H	A194 - 8
13	HINGE PIN	A576 - 1020	A576 - 1020	A479 - 304
14	PACKING GLAND	A576 - 1020 + Cr	A479 - 410	A479 - 304
15	BONNET BOLT	A193 - B7	A193 - B16	A193 - B8
16	BONNET NUT	A194 - 2H	A194 - 4	A194 - 8
17	YOKE CAP	A576 - 1020	A576 - 1020	A576 - 1020 + Zn
18	YOKE SLEEVE	A439 - D2C	A439 - D2C	A439 - D2C
19	HANDLE NUT	A47- 32510 + Zn	A47- 32510 + Zn	A47- 32510 + Zn
20	SET SCREW	STEEL	STEEL	STEEL +Cr
21	NIPPLE	STEEL + Cr	STEEL + Cr	STEEL +Cr
22	GEAR BOX	DUCTILE IRON	DUCTILE IRON	DUCTILE IRON
23	STEM COVER	A53	A53	A53

DIMENSION AND WEIGHT

CLASS 150

UNIT : mm

SIZE	2	3	4	6	8	10	12	14	16	18	20	24	26	28	30
L	177.8	203.2	228.6	266.7	292.1	330.2	355.6	381.0	406.4	431.8	457.2	508.0	558.8	609.6	609.6
L1	215.9	282.4	304.8	403.4	419.1	457.2	501.7	571.5	609.6	660.4	711.2	812.8	-	-	-
D	200	224	250	315	355	400	450	500	560	630	710	800	-	900	900
D1	-	-	-	250	250	355	355	355	500	500	630	630	710	710	710
H	339	441	535	735	927	1125	1317	1550	1823	1900	2120	2502	-	2873	3066
H1	-	-	-	950	1071	1260	1462	1658	1830	2058	2268	2660	2950	3052	3268
WEIGHT(Kg)	16	29	43	72	116	173	263	388	535	648	822	1276	1552	1777	2119

CLASS 300

UNIT : mm

SIZE	2	3	4	6	8	10	12	14	16	18	20	24	26	28	30
L	215.9	282.4	304.8	403.4	419.1	457.2	501.7	762.0	838.2	914.4	990.6	1143.0	1244.6	1346.2	1397
L1	215.9	282.4	304.8	403.4	419.1	457.2	501.7	762.0	838.2	914.4	990.6	1143.0	-	-	-
D	200	224	250	355	400	450	500	560	630	710	800	900	-	-	-
D1	-	-	-	250	355	355	355	500	500	630	630	710	800	800	900
H	340	442	536	745	951	1142	1325	1631	1692	1909	2119	2492	-	-	-
H1	-	-	-	895	1087	1269	1470	1669	1849	2065	2272	2667	3057	3265	3475
WEIGHT(Kg)	22	41	59	119	193	291	410	687	876	1201	1500	2258	3026	3450	4147

CLASS 600

UNIT : mm

SIZE	2	3	4	6	8	10	12	14	16	18	20	24	26	28	30
L	292.1	355.6	431.8	558.8	660.4	787.4	838.2	889.0	990.6	1092.2	1193.8	1397.0	1447.8	1549.4	1651
L1	292.1	355.6	431.8	558.8	660.4	787.4	838.2	889.0	990.6	1092.2	1193.8	1397.0	-	-	-
D	200	250	355	450	500	630	-	-	-	-	-	-	-	-	-
D1	-	-	-	355	500	500	630	630	710	710	800	900	900	900	900
H	394	475	591	801	1005	1192	-	-	-	-	-	-	-	-	-
H1	-	-	-	995	1233	1360	1605	1792	2079	2160	2366	2740	3002	3235	3480
WEIGHT(Kg)	35	64	110	222	405	626	878	1165	1490	1836	2410	3639	4437	5589	6933

CLASS 900

UNIT : mm

SIZE	2	3	4	6	8	10	12	14	16	18	20	24
L	368.3	381.0	457.2	609.6	736.6	838.2	965.2	1028.7	1130.3	1219.2	1320.8	1549.4
L1	368.3	381.0	457.2	609.6	736.6	838.2	965.2	1028.7	1130.3	1219.2	1320.8	1549.4
D	250	355	355	500	630	710	-	-	-	-	-	-
D1	-	250	250	500	500	630	710	710	710	900	900	900
H	474	623	718	958	1290	1451	-	-	-	-	-	-
H1	-	678	900	1112	1322	1542	1786	1792	1955	2308	2466	2889
WEIGHT(Kg)	73	103	159	318	568	908	1234	1628	2288	3025	3850	5200

CLASS 1500

UNIT : mm

SIZE	2	3	4	6	8	10	12	16
L	368.3	469.9	546.1	704.9	831.9	990.6	1130.3	1384.4
L1	368.3	469.9	546.1	704.9	831.9	990.6	1130.3	-
D	250	355	400	560	800	900	-	1092
D1	-	-	355	500	630	710	800	800
H	474	603	730	944	1205	1414	-	2129
H1	-	-	880	1106	1350	1570	1826	2341
WEIGHT(Kg)	81	141	227	515	992	1603	2572	5255

GLOBE VALVES

FUNCTION

The globe valve is used where throttling alone or both throttling and shutoff is needed. It may also be used for on-off service, but because of high pressure drop, such application is limited to the cases that the valve is normally closed and the pressure drop is of no importance in valve open condition.

PK cast steel globe valve is regularly made in outside screw and yoke design with full-way type disc.

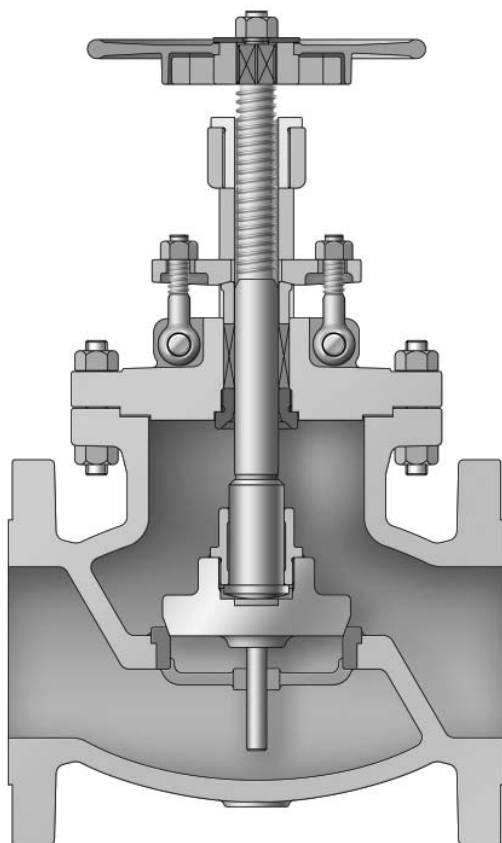

BODY AND BONNET

The body has a spherical form with large radius, which permits the stress, turbulence and resistance to flow to be kept minimum. The bonnets on valve are equipped with back seat rings.

BODY-BONNET JOINT

Body-bonnet joint of globe valve is machined as follows:

All Male and female.

We can supply any kinds of gasket as required by customer.

DISC

The valve is normally supplied with plug type disc.

SEAT RING

The valve is normally supplied with bottom seated type on 8" or larger valves, and the disc has bottom guide type seat rings.

STEM

All stem have the turning and rising cut ACME threads.

YOKE BUSH

The yoke nuts on globe valve are threaded and mounted to the bonnet, where it is secured with tack welding.

PACKING

The packing size is designed to secure maximum tightness along the stem, and the standard packing is a non-asbestos type. We can supply any kinds of packing as required by customer.

GLAND

The gland is made of two pieces. Packing gland is in contact with the packing which is connected to gland flange through a spherical joint. Particular design permits a correct pressure on the packing without any damage to stem due to friction or corrosion.

STUFFING BOX

The stuffing box gives maximum packing stem seal. Lantern ring and grease injector shall be furnished only if specified on the purchase order.

HAND WHEELS

Hand wheels are designed for easy operation. They are provided with hammer blow type of 8" and over for Class 150 valves, 6" and over for Class 300 and, 4" and over for Class 600, and 2.5" and over for Class 900 & 1500. With gearing, motor actuator or cylinder actuator, They are also available for more difficult services.



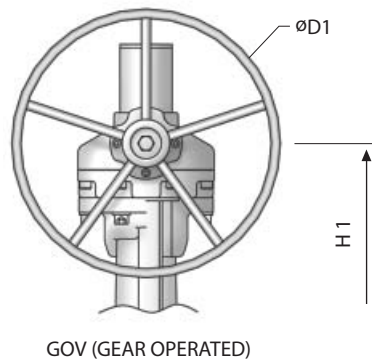
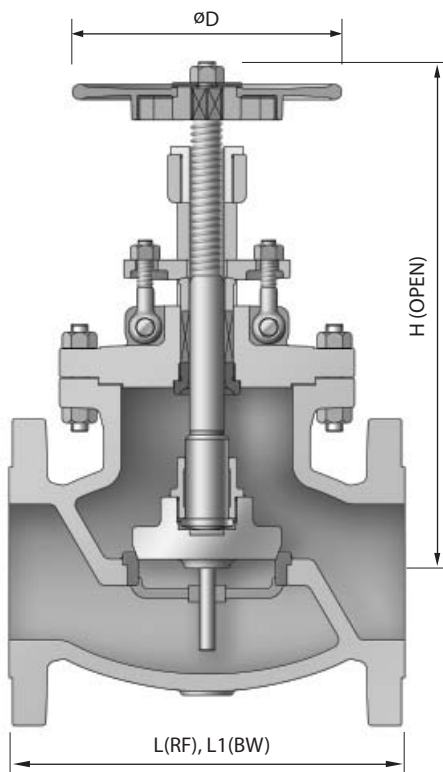

END CONNECTION

- R.F FLANGED ENDS TO ASME B16.5
- B.W. ENDS TO ASME B16.25
- R.T.J FLANGED ENDS TO ASME B16.5
- SIZE 26" AND LARGER, FLANGED ENDS ACCORDING TO ASME B16.47 SER.A OR SER.B

STANDARD MATERIAL SPECIFICATIONS

NO.	PART NAME	MATERIAL		
1	BODY	A216 - WCB	A217 - WC6	A351 - CF8M
2	BONNET	A216 - WCB	A217 - WC6	A351 - CF8M
3	DISC	A217 - CA15+STL	A217 - CA15+STL	A351 - CF8+STL
4	STEM	A479 - 410	A479 - 410	A479 - 304
5	HAND WHEEL	DUCTILE IRON	DUCTILE IRON	DUCTILE IRON
6	BODY SEAT RING	A216 - WCB+STL	A217 - WC6+STL	A351 - CF8+STL
7	BACK SEAT RING	A479 - 410	A479 - 410	A479 - 304
8	GASKET	SPIRAL WOUND / GRAPHITE+304+304		
9	PACKING	GRAPHITE+GRAPHITE WITH INCONEL WIRE		
10	GLAND FLANGE	A283 - D	A283 - D	A351 - CF8
11	HINGE BOLT	A307 - B	A307 - B	A193 - B8
12	HINGE NUT	A194 - 2H	A194 - 2H	A194 - 8
13	HINGE PIN	A576 - 1020	A576 - 1020	A479 - 304
14	PACKING GLAND	A576 - 1020+Cr	A479 - 410	A479 - 304
15	BONNET BOLT	A193 - B7	A193 - B16	A193 - B8
16	BONNET NUT	A194 - 2H	A194 - 4	A194 - 8
17	YOKE BUSH	A439 - D2C	A439 - D2C	A439 - D2C
18	LOCK NUT	A479 - 410	A479 - 410	A479 - 304
19	HANDLE NUT	A563 - A	A563 - A	A194 - 8
21	SHAKE ADAPTER	DUCTILE IRON	DUCTILE IRON	DUCTILE IRON
22	HANDLE COVER	A283 - D	A283 - D	A283 - D
23	GEAR BOX	DUCTILE IRON	DUCTILE IRON	DUCTILE IRON
24	STEM COVER	A53	A53	A53

DIMENSION AND WEIGHT

CLASS 150

UNIT : mm

SIZE	2	3	4	6	8	10	12	14	16	18	20	24
L	203.2	241.3	292.1	406.4	495.3	622.3	698.5	787.4	914.4	978.0	978.0	1295.4
L1	203.2	241.3	292.1	406.4	495.3	622.3	698.5	787.4	914.4	978.0	-	-
D	200	250	315	355	355	400	400	-	-	-	-	-
D1	-	-	-	-	450	450	500	560	630	630	800	800
H	284	344	388	505	623	805	839	-	-	-	-	-
H1	-	-	-	-	577	626	800	922	980	1140	1825	2029
WEIGHT(Kg)	14	27	43	91	178	256	409	616	825	960	1387	1988

CLASS 300

UNIT : mm

SIZE	2	3	4	6	8	10	12	16	18	20	24	28
L	266.7	317.5	355.6	444.5	558.8	622.3	711.2	863.6	914.4	1016.0	1346.2	1498.6
L1	266.7	317.5	355.6	444.5	558.8	622.3	711.2	863.6	-	-	-	-
D	200	250	315	355	400	450	500	-	-	-	-	-
D1	-	-	-	-	500	560	630	710	710	800	800	800
H	286	346	392	618	793	1145	1260	-	-	-	-	-
H1	-	-	-	-	805	880	971	1120	1220	1674	2086	2338
WEIGHT(Kg)	20	37	58	140	260	422	567	975	1700	2090	3481	4590

CLASS 600

UNIT : mm

SIZE	2	3	4	6	8	10	12	14	16	18	20	24	30
L	292.1	355.6	431.8	558.8	660.4	787.4	838.2	889.0	990.6	1092.2	1193.8	1397.0	1651.0
L1	292.1	355.6	431.8	558.8	660.4	787.4	838.2	-	-	-	-	-	-
D	224	315	315	450	-	-	-	-	-	-	-	-	-
D1	-	-	-	500	560	630	800	800	800	800	800	800	800
H	392	478	531	675	-	-	-	-	-	-	-	-	-
H1	-	-	-	689	754	959	1690	1871	2015	2449	2504	2595	3237
WEIGHT(Kg)	35	63	120	233	415	652	1316	1565	2120	3110	3490	4320	10800

CLASS 900

UNIT : mm

SIZE	2	3	4	6	8	12	14
L	368.3	381.0	457.2	609.6	736.6	965.2	1029
L1	358.3	381.0	457.2	609.6	736.6	965.2	-
D	315	315	355	450	710	-	900
D1	-	-	400	560	630	710	-
H	498	513	605	730	894	-	1913
H1	-	-	600	710	970	1101	-
WEIGHT(Kg)	77	103	177	388	655	1288	1500

CLASS 1500

UNIT : mm

SIZE	2	3	4	6	8	14
L	368.3	469.9	546.1	704.9	831.9	990.6
L1	358.3	469.9	546.1	704.9	831.9	990.6
D	315	355	400	500	800	-
D1	-	-	400	630	710	800
H	497	584	714	1065	1191	-
H1	-	-	700	1105	1100	1206
WEIGHT(Kg)	77	147	262	669	1187	1827

SWING CHECK VALVES

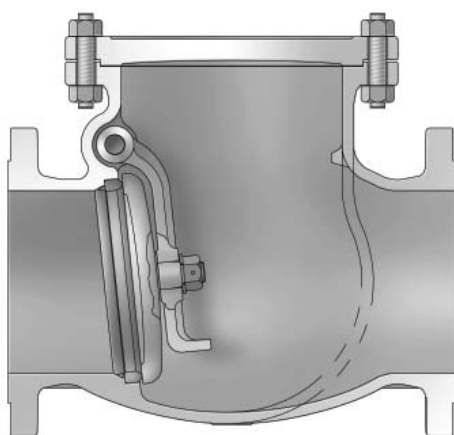
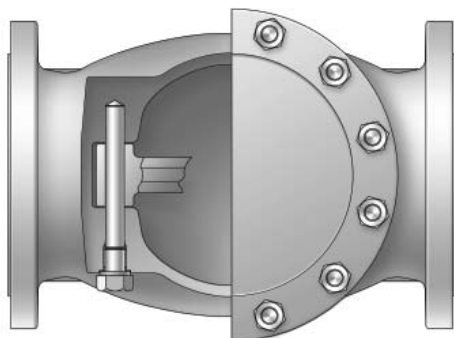

FUNCTION

The swing check valve is designed so that it is opened automatically at the forward flow and closed at the reverse flow in horizontal or vertical (upward flow only through valve) piping runs. It has an advantage of low pressure drop and therefore is best suitable for velocity application.

BODY

The body has a spherical form with large radius, which permits the stress, turbulence and resistance to flow to be kept minimum.

BODY-COVER JOINT

Body-cover joint of swing check valve is machined as follows:

- Class 150 Male and female.
- Class 300 and 600 Male and female.
- Class 900 higher class Ring type joint.

We can supply any kinds of gasket as required by customer.

SEAT RING

The seat ring as a welded-in type is designed to prevent any turbulence and damage by corrosion. It is forged or rolled into one piece for all dimensions, heat treated to obtain the desired surface hardness, and cleaned thoroughly before assembling.

END CONNECTIONS

In our standard production of valves, the flange ends (RF) and the face to face dimensions conform to ANSI B16.5 and ASME B16.10, respectively, and they have a raised face serrated finish type or other finish type as requested.

For butt-welded ends (B.W), of which the end to end dimension conforms to ASME B16.10, customer must specify the schedule type required, pipe class, or bore diameter.

Ring joint flanged ends (R.T.J) conform to ASME B16.5 and the end to end dimension follows ASME B16.10. The other special end connections may be supplied as required by customer.

HINGE ARRANGEMENT

- Body penetration is sealed with blind flange and spiral-wound gasket
- Arm pin is located near the disc center of gravity, minimizing sealing surface radius rotation and thus velocity.

ARM ARRANGEMENT

- Hydrofoil profile maintains the disc stability while being lifted by a hydrodynamic force at a flow including pulsating.
- Heavy-balanced weight insures that disc goes to seat immediately upon cessation of flow and minimizes water hammer.

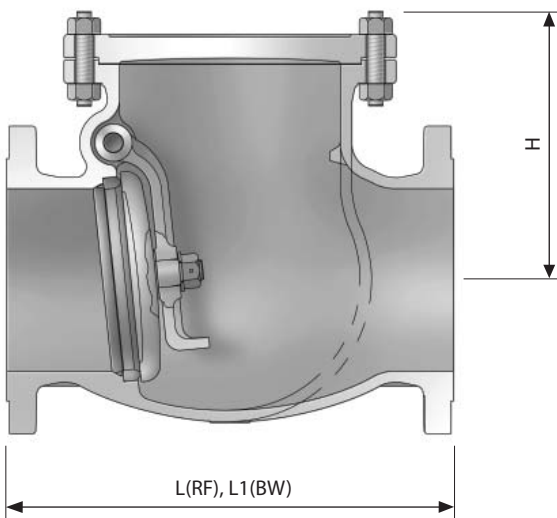
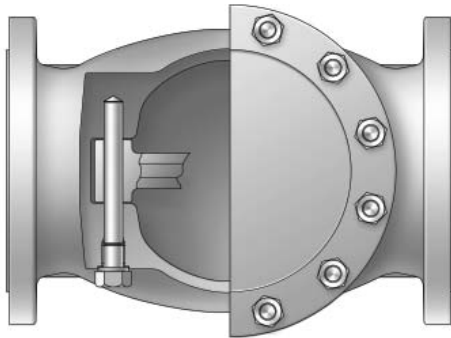

END CONNECTION

- R.F FLANGED ENDS TO ASME B16.5
- B.W. ENDS TO ASME B16.25
- R.T.J FLANGED ENDS TO ASME B16.5
- SIZE 26" AND LARGER, FLANGED ENDS ACCORDING TO ASME B16.47 SER.A OR SER.B

STANDARD MATERIAL SPECIFICATIONS

NO.	PART NAME	MATERIAL		
1	BODY	A216 - WCB	A217 - WC6	A351 - CF8
2	BONNET	A216 - WCB	A217 - WC6	A351 - CF8
3	DISC	A217 - CA15+STL	A217 - CA15+STL	A351 - CF8+STL
4	ARM	A216 - WCB	A216 - WC6	A351 - CF8
5	ROD PIN	A479 - 410	A479 - 410	A479 - 304
6	BODY SEAT RING	A576 - 1020+STL(S20C)	A182 - F11+STL	A240+304+STL
7	PLUG BOLT	A307 - B	A479 - 304	A479 - 304
8	GASKET	SPIRAL WOUND / GRAPHITE+304+304		
9	PLUG GASKET	SOFT STEEL	304 S.S	304 S.S
10	BONNET BOLT	A193 - B7	A193 - B16	A193 - B8
11	BONNET NUT	A194 - 2H	A194 - 4	A194 - 8
12	DISC NUT	A194 - 8	A194 - 8	A194 - 8
13	PIN	304 S.S	304 S.S	304 S.S
14	WASHER	304 S.S	304 S.S	304 S.S

DIMENSION AND WEIGHT

CLASS 150

UNIT : mm

SIZE	2	3	4	6	8	10	12	14	16	18	20	24	26	28	30
L	203.2	241.3	292.1	355.6	495.3	622.3	698.5	787.4	863.6	977.9	977.9	1295.4	1295.4	1447.8	1524
L1	203.2	241.3	292.1	355.6	495.3	622.3	698.5	787.4	863.6	977.9	977.9	1295.4	-	-	-
H	160	190	225	260	320	350	380	405	460	505	570	680	865	918	962
WEIGHT(kg)	16	26	45	78	136	214	319	412	514	749	933	1346	1727	1964	2247

CLASS 300

UNIT : mm

SIZE	2	3	4	6	8	10	12	14	16	18	20	24	26	28	30
L	266.7	317.5	355.6	444.5	533.4	622.3	711.2	838.2	863.6	977.9	1016.0	1346.2	1346.2	1498.6	1593.9
L1	266.7	317.5	355.6	444.5	533.4	622.3	711.2	838.2	863.6	977.9	1016.0	1346.2	-	-	-
H	160	199	227	278	322	383	435	510	521	572	622	712	979	983	1115
WEIGHT(kg)	21	42	54	124	222	291	444	632	786	1058	1210	1916	2000	2600	3664

CLASS 600

UNIT : mm

SIZE	2	3	4	6	8	10	12	14	16	18	20	24	26	30
L	292.1	355.6	431.8	558.8	660.4	787.4	838.2	889.0	990.6	1092.2	1193.8	1397.0	-	1651
L1	292.1	355.6	431.8	558.8	660.4	787.4	838.2	889.0	990.6	1092.2	1193.8	1397.0	1448	-
H	197	210	256	329	364	464	486	572	660	711	787	864	1028	1135
WEIGHT(kg)	31	56	103	204	342	624	776	938	1250	1518	2390	3686	4000	5502

CLASS 900

UNIT : mm

SIZE	2	3	4	6	8	10	12	14	16	18	20	24
L	368.3	381.0	457.2	609.6	736.6	838.2	965.2	1028.7	1130.3	1219.2	1320.8	1549.4
L1	368.3	381.0	457.2	609.6	736.6	838.2	965.2	1028.7	1130.3	1219.2	1320.8	1549.4
H	267	290	306	338	460	500	578	647	710	785	850	1006
WEIGHT(kg)	68	106	139	294	525	731	1025	1444	1850	2610	3407	5842

CLASS 1500

UNIT : mm

SIZE	2	3	4	6	8	10	12	16
L	368.3	469.9	546.1	704.9	831.9	990.6	1130.3	1384.3
L1	368.3	469.9	546.1	704.9	831.9	990.6	1130.3	1384.3
H	267	296	355	465	540	657	728	1116
WEIGHT(kg)	73	125	212	470	825	960	1510	4630

TILTING DISC CHECK VALVES

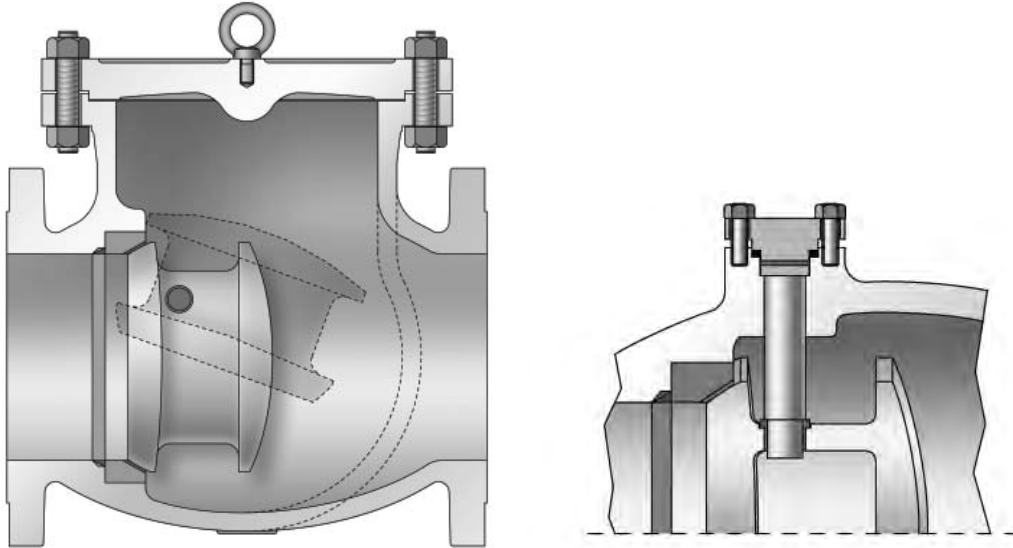

FUNCTION

Today, higher velocity and pressure of piping often requires a sophisticated check valve rather than conventional swing type valve. PK tilting disc check valve is designed to handle such higher velocities, prevent damages due to turbulence and avoid “water hammer” phenomenon in piping systems, and it is closed quickly and quietly. The valve is closed quickly because its pivot(hinge pins) is shut by a very small arc. Moreover, line fluid flows both over and under the disc, so that valve closing is cushioned by the line fluid itself. By virtue of quick and quiet closing ability, up to now PK tilting disc check valve has earned good reputation as a “non-slam” check valve.

BODY

Body-cover joint of swing-check valve are machined as follows:

Class 150 Male and female.

Class 300 and 600 Male and female.

Class 900 and 1500 Ring type joint.

We can supply any kind of gasket per customer requirements.

SEAT RING

Seat rings are welded into valve bodies in order to prevent turbulence and avoid damage due to corrosion seats, forged or rolled in one piece for all dimensions, heat treated to obtain the required surface hardness, and perfectly cleaned before assembly.

END CONNECTIONS

Our standard production covers valves with;

FLANGED ENDS(RF) that conform to ASME B16.5 and face to face dimensions that conform to ASME B16.10, with a raised face serrated finish or, on request, with any other finish;

BUTT-WELDING ENDS(B.W) with end to end dimensions that conform to ASME B16.10;

(Customer must specify the schedule required, or class of pipe, or diameter and bore.)

RING JOINT FLANGED ENDS(R.T.J) that conform to ASME B16.5 and with end to end dimensions to ASME B16.10; Other special end connections are supplied to customer requirements.

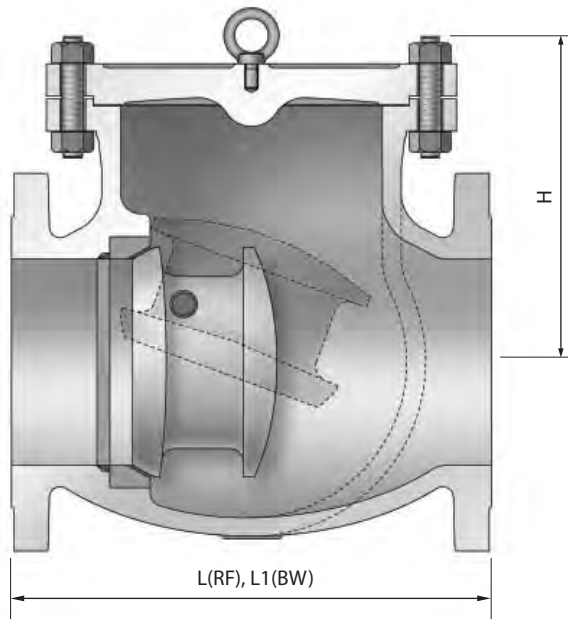

END CONNECTION

- R.F FLANGED ENDS TO ASME B16.5
- B.W. ENDS TO ASME B16.25
- R.T.J FLANGED ENDS TO ASME B16.5
- SIZE 26" AND LARGER, FLANGED ENDS ACCORDING TO ASME B16.47 SER.A OR SER.B

STANDARD MATERIAL SPECIFICATIONS

NO.	PART NAME	MATERIAL		
1	BODY	A216 - WCB	A217 - WC6	A351 - CF8
2	BONNET	A216 - WCB	A217 - WC6	A351 - CF8
3	DISC	A216 - WCB+STL	A217 - WC6+STL	A351 - CF8+STL
4	BODY SEAT RING	A576 - 1020+STL(S20C)	A182 - F11+STL	A240 - 304+STL
5	GASKET	SPIRAL WOUND / GRAPHITE+304+304		
6	HINGE PIN	A479 - 410	A479 - 410	A479 - 304
7	BUSHING	A479 - 304	A479 - 304	A479 - 304
8	BONNET BOLT	A193 - B7	A193 - B16	A193 - B8
9	BONNET NUT	A194 - 2H	A194 - 4	A194 - 8
10	COVER	A576 - 1020	A240 - 304	A240 - 304
11	COVER BOLT	A193 - B7	A193 - B7	A193 - B8
12	COVER NUT	A194 - 2H	A194 - 2H	194 - 8
13	COVER GASKET	SPIRAL WOUND / GRAPHITE+304		
14	EYE BOLT	A307 - B	A307 - B	A307 - B+Cr

DIMENSION AND WEIGHT

CLASS 150

UNIT : mm

SIZE	2	3	4	6	8	10	12	14	16	18	20	24	26	30
L	203.2	241.3	292.1	355.6	495.3	622.3	698.5	787.4	863.6	977.9	977.9	1295.4	1295.4	1524
L1	203.2	241.3	292.1	355.6	495.3	622.3	698.5	787.4	863.6	977.9	977.9	1295.4	-	-
H	152	190	195	242	298	320	384	381	465	517	579	597	820	970
WEIGHT(kg)	19	31	54	94	163	257	383	494	617	899	1120	1615	2072	2696

CLASS 300

UNIT : mm

SIZE	2	3	4	6	8	10	12	14	16	18	20	24	26	28
L	266.7	317.5	355.6	444.5	533.4	622.3	711.2	838.2	863.6	977.9	1016.0	1346.2	1346.2	1498.6
L1	266.7	317.5	355.6	444.5	533.4	622.3	711.2	838.2	863.6	977.9	1016.0	1346.2	-	-
H	163	202	205	331	298	345	425	490	494	554	578	690	909	977
WEIGHT(kg)	25	50	77	149	266	349	533	758	943	1270	1452	2299	2400	3120

CLASS 600

UNIT : mm

SIZE	2	3	4	5	8	10	14	16	18	20	26	28	30
L	292.1	355.6	431.8	558.8	660.4	787.4	889.0	990.6	1092.2	1193.8	1447.8	1600.2	1651
L1	292.1	355.6	431.8	558.8	660.4	787.4	889.0	990.6	1092.2	1193.8	-	-	-
H	170	190	225	305	379	466	520	534	697	695	1216	1176	1306
WEIGHT(kg)	37	67	124	245	410	749	1126	1500	1822	2868	5560	5810	7150

CLASS 900

UNIT : mm

SIZE	3	4	5	8	10	16
L	381.0	457.2	609.6	736.6	838.2	1130.3
L1	381.0	457.2	609.6	736.6	838.2	1130.3
H	288	292	378	448	510	948
WEIGHT(kg)	127	167	353	530	877	2220

CLASS 1500

UNIT : mm

SIZE	2	3	4	6	8	10	12	14	15
L	368.3	469.9	546.1	704.9	831.9	990.6	1130.3	1257.3	1384.3
L1	368.3	469.9	546.1	704.9	831.9	990.6	1130.3	1257.3	1384.3
H	260	288	350	434	512	633	722	873	948
WEIGHT(kg)	88	150	254	564	990	1152	1812	3582	5556

DUAL PLATE CHECK VALVES

TYPICAL CONSTRUCTIONS

Dual plate check valves are supplied retainerless as standard. Our patented design does not have any threaded plugs in the pressure boundary and totally eliminates the potential leakpath to atmosphere. This design meet fugitive emission control.

VALVE FEATURES & ADVANTAGES

- Dual plate Check Valve is economical on installation and maintenance because installation is required less and light weight.
- Dual plate Check Valve is possible to prevent water hammering due to closing valve disk by operating the spring in valve before back flow. Also Due-Check valve prevents large piping the for big gap water levels.
- Dual plate Check Valve can apply variously in piping line because of less than existing Check Valve on restrictions of instaling direction.
- Life spans is longer than existing Check Valve, and preservation and repair are simple.
- It's possible to reduce maintenance fee due to longer durability than existing check valve, easy maintenance.

RANGE		APPLICATION
NORMINAL SIZE		1 1/2"(40A) - 84"(2100A)
FLUID		Water, Air, Steam, Gas, Sea Water
RATING		JIS 10K, 20K, 30K, ANSI 150#, 300#, 600#, 900#, 1500#, PN 10, 16, 20, 40, AWWA C 207
END CONNECTION		Wafer, Lugged, Flanged
TEMP. RANGE		-50 ~ 600°C
MATERIAL	BODY	A126-CLB, A536 Gr. Carbon Steel (A216-WCB etc.) Stainless Steel (CF8, CF8M, CF3 etc.) B148-C97800, Special Steel (Alloy etc.)
	DISC	Carbon Steel (A216-WCB etc.) Stainless Steel (CF8, CF8M, CF3 etc.) B148-C95800, Special Steel (Alloy etc.)
	SEAT	Rubber (EPDM, Buna-N etc.) Metal (Stainless Steel, Stellite #6 etc.)
	SPRING	Stanless Steel (304, 316 etc) Inconel (625, X750 etc)

MATERIAL TEMPERATURE LIMITS

UPPER TEMPERATURE LIMITS

MATERIAL	UPPER LIMIT F(°C)
316SS	250(121)
INCONEL X 750	1000(537)
MONEL	400(204)
HASTELLOY	800(426)
ALLOY20	250(121)
BUNA-N(NBR)	250(121)
EPDM	300(149)
PTFE	450(232)
METAL OVELAY	AS BODY
METAL TO METAL	AS BODY

LOWER TEMPERATURE LIMITS

MATERIAL	LOWER LIMIT F(°C)
WCB	-20(-28.9)
LCC	-50(-45.6)
CF8M	-450(-268)
BUNA-N(NBR)	-70(-56.7)
EPDM	-14(-11.4)
VITON	-40(-40)
PTFE	-200(-129)
METAL TO METAL	AS BODY

STANDARD DESIGN

WAFER TYPE

Retainerless design supplied as standard

- **ANSI B16.5**

- Flange dims to ANSI B16.5 (MSS-SP44>24")
- Face to face dims to API 594

- **API 605**

- Flange dims to API 605
- Face to face dims to API 594

FLANGED TYPE

- Flange dims to ANSI B16.5 (MSS-SP44>24")
- Face to face dims to API 594

- **API 6A**

- Flange dims to API 6A
- Face to face dims to API 6A

- **API 6D**

- Flange dims to ANSI B16.5
- Face to face dims to API 6D

SOLID LUG TYPE

- Flange dims to ANSI B16.5 (MSS-SP44>24")
- Face to face dims to API 594
- * Threaded lug type also available

- **JIS 2210 & KS B1511**

- **EXTENDED BODY**

- Flange dims to ANSI B16.5

PRESSURE CLASSES •ASME 150 TO 1500 LB, PN 10 TO 40. •JIS & KS 5K TO 20K

NOMINAL SIZE RANGE

ASME 150 lb.2" to 60"
ASME 300 lb.2" to 40"
ASME 600 lb.2" to 36"
ASME 900 lb.2" to 36"
ASME 1500 lb.2" to 24"

Larger diameter valves for the respective pressure classes can be designed and manufactured on request.

RETAINERLESS DESIGN

Dual plate check valves are supplied retainerless as standard. Our patented design does not have any threaded plugs in the pressure boundary and totally eliminates the potential leakpath to atmosphere. This design meet fugitive emission control.

SEAT

The seat is designed equal pressure at the plate with the state of stationary hour. The shape of rubber seat could not be changed even in many operation because of having its most hardness satisfaction. The metal to metal seated valve is tested to API 598.

DISC (PLATE)

The two semicircle plate responsiveness of opening and closing is quick and it is strong against corrosion also has a strong durability.

SPRING

The springs have been designed to endure stresses and also ensure operating without failure for much cycles.

RUBBER LINED

Fully Rubber Lined Valves to avoid corrosion Inside are available.

DUAL PLATE CHECK VALVE TYPES



Wafer Retainerless



Flanged Retainerless



Solid Lug Retainerless



Hub Ended

STANDARD MATERIAL SPECIFICATIONS

NO.	PART NAME	MATERIAL		
1	BODY	A216 - WCB	A351 CF8M	A351 CF3M
2	DISC	A351 CF8M	A351 CF3M	A217 CA15
3	SEAT	SS 316	13 CR	STELLITE \$6
4	HINGE PIN	A276 316	A276 410	A276 304
5	STOP PIN	A276 316	A276 410	A276 304
6	SPRING	INCONEL X-750	SS 316	
7	GUIDE	A276 316	A276 410	A276 304
8	WASHER	A276 316	A276 304	
9	SET SCREW	A193 B7	A193 B8	A193 B8m
10	EYE BOLT	SS400 or SS304	SET SCREW	SS304

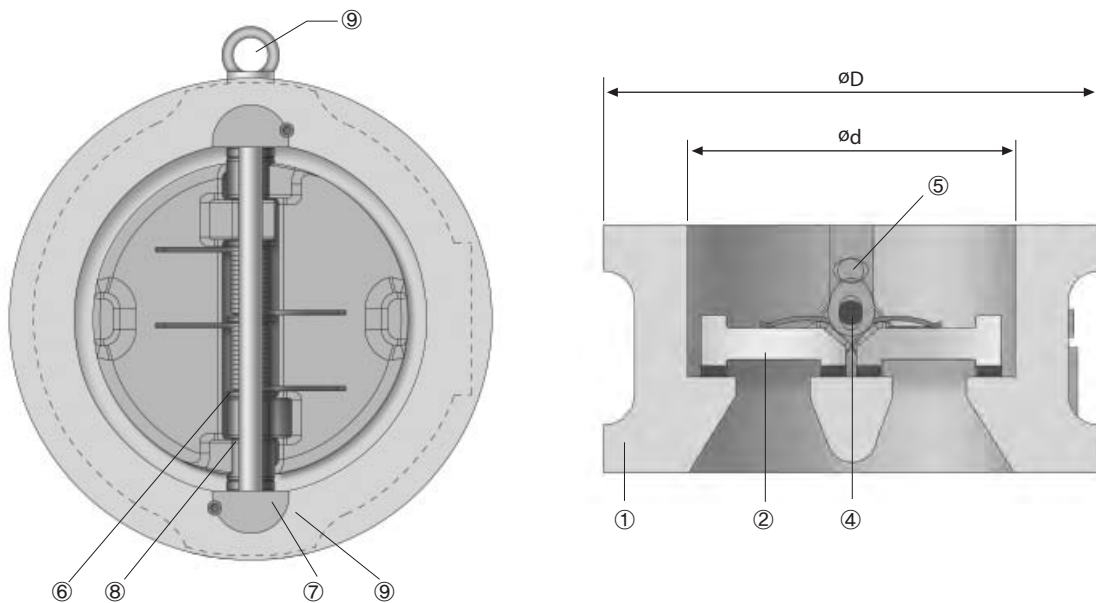

DIMENSION AND WEIGHT

CLASS 150

UNIT : mm

SIZE	2"	3"	4"	6"	8"	10"	12"	14"	16"	18"	20"	24"
ØD	102	133	171	219	276	337	406	448	511	546	603	714
Ød	60	87	113	166	207	260	300	339	387	438	487	580
L	60	73	73	98	127	146	181	184	191	203	219	222

CLASS 300

UNIT : mm

SIZE	2"	3"	4"	6"	8"	10"	12"	14"	16"	18"	20"	24"
ØD	108	146	178	248	305	359	419	483	537	594	651	772
Ød	60	87	113	166	207	260	300	339	387	438	487	580
L	60	73	73	98	127	146	181	222	232	264	292	318

CLASS 600

UNIT : mm

SIZE	2"	3"	4"	6"	8"	10"	12"	14"	16"	18"	20"	24"
ØD	108	146	191	264	317	397	454	489	562	610	679	787
Ød	60	87	113	166	207	260	300	339	387	438	487	580
L	60	73	79	137	165	213	229	273	305	362	368	438

CLASS 900

UNIT : mm

SIZE	2"	3"	4"	6"	8"	10"	12"	14"	16"	18"	20"	24"
ØD	140	165	203	286	356	432	495	518	571	635	695	835
Ød	60	87	113	166	207	260	300	339	387	438	487	580
L	70	83	102	159	206	241	292	356	384	451	451	495

CLASS 1500

UNIT : mm

SIZE	2"	3"	4"	6"	8"	10"	12"	14"	16"	18"	20"	24"
ØD	140	171	206	279	349	432	518	575	638	702	752	899
Ød	60	87	113	166	207	260	300	339	387	438	487	580
L	70	83	102	159	206	248	305	356	384	468	533	559

MEMO

Fully Integrated, Yet Flexible
PKvalve

PRESSURE SEAL VALVES

- *GATE VALVES*
- *GLOBE VALVES*
- *SWING CHECK VALVES*
- *TILTING DISC CHECK VALVES*



PRESSURE SEAL VALVES

PRODUCTION MATERIALS

CLASS TYPE	UNIT : NPS			
	600	900	1500	2500
GATE	2 - 60	2 - 48	2 - 48	2 - 48
GLOBE	2 - 24	2 - 24	2 - 24	2 - 24
SWING CHECK	2 - 24	2 - 42	2 - 42	2 - 42
TILTING CHECK	2 - 24	2 - 42	2 - 42	2 - 42
Y-GLOBE	2 - 24	2 - 24	2 - 24	2 - 24
ANGLE GLOBE	2 - 24	2 - 24	2 - 24	2 - 24

- Carbon Steel : ASTM A216-WCB or Equivalent
- Alloy Steel : ASTM A217-WC6,WC9,C5,C12,C12A, ASTM A182-F91 or Equivalent
- Stainless Steel : ASTM A351-CF8,CF8M,CF3,CF3M, CN7M or Equivalent
- Duplex Stainless Steel : ASTM A995-1A,2A,4A,5A or Equivalent
- Special Alloy Steel : Inconel 625, Incoloy 825, Hastelloy C, Monel ASME SA designation material(e.g ASME SA217-WC6)

DESIGN

Pressure seal valves are intended for high pressure and high temperature applications in all types of fluid, except where severe coking may occur.

A selection of design and material would give an excellent service in nuclear steam generating stations, industrial/chemical plants and thermal power plants.

The pressure seal valves provide the most efficient use for flow passage and sealing, and result in significant weight saving and ease and simple installation and maintenance. Manufacturing and quality assurance procedures include extra controls of dimensional and non-destructive examinations and tests on critical areas such as gasket sealing, weld ends, or stellite sealing surfaces.

CONSTRUCTION

- BODY AND BONNET
 - BODY : Flow areas are designed for minimum turbulence and pressure drop.
 - BONNET : Ample stuffing box and stellite back seat are to guide accurately stem and back seat.
- When designing a PK valve, casting of body and bonnet shall be considered thoroughly as a quality requirement.

- BONNET TYPE

Type A

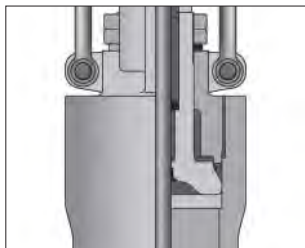

GATE
Class 600,900,1500 & 2500
Size 4" & smaller
GLOBE
Class 600,900,1500
Size 4" & smaller
Class 2500
Size 3" & smaller

Type B

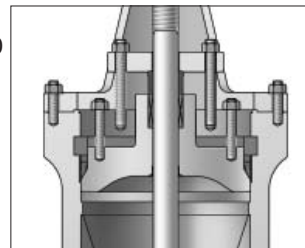

GATE
Class 600,900,1500 & 2500
Size 6" & larger
GLOBE
Class 600,900,1500
Size 6" & larger
Class 2500
Size 4" & larger

Type C

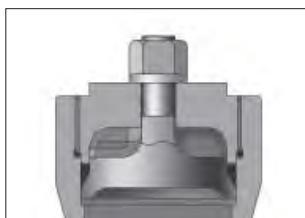

SWING CHECK
Class 600,900,1500 & 2500
Size 4" & smaller
Class 2500
Size 3" & smaller

Type D

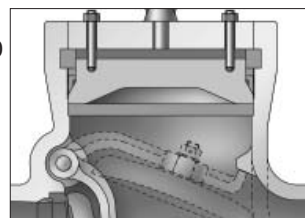

SWING CHECK
Class 600,900,1500 & 2500
Size 6" & larger
Class 2500
Size 4" & larger

GATE VALVES

FLEXIBLE GATE

A flexible wedge is a one piece and fully guided cast with a central hub allowing the seating faces to move reciprocally and thus compensating for the distortion on body seats due to thermal expansion or pipe loads.

Seat ring and wedge seating face are set to 9° angle from the vertical to minimize the sliding contacts between wedge and seat ring while opening or closing them.

Wedging helps lead to a tight seal in a low differential pressure service.

A flexible wedge resists wedge sticking or binding in a service. The wedge may be closed in a hot condition and opened in cold. The seating surface are stellite to provide high cycle capability in a very high differential pressure service.

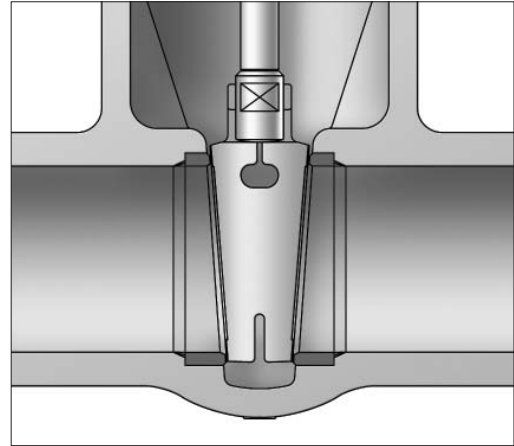

STANDARD PRESSURE SEAL DESIGN

A segment thrust ring absorbs all the thrusts applied by internal pressure. A protective ring made by hardened stainless steel prevents the deformation on the top surface of soft metal gasket. The gasket can be removed smoothly without any damage on the sealing surface of body.

PACKING ADJUSTMENT

All gate and globe valves have a two-piece packing gland to minimize the scoring on valve stem which may occur if tightened unevenly. Gland bolts remain fastened to the bonnet. They swing out of the way to simplify the packing replacement and are oriented to adjust the packing from one side of valve.

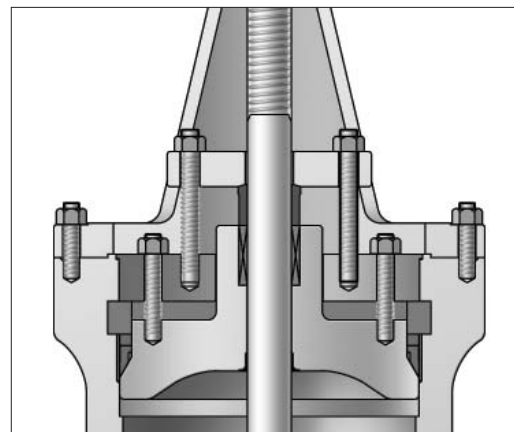

DEEP STUFFING BOXES

Deep stuffing boxes are standard type for gate and globe valves.

They allow for extra packing to ensure more reliable stem seal and sufficient packing depth containing an optional lantern ring in the middle of box. where lantern ring is included, a tapped and plugged hole is made. If specified, a ball grease injector can be fitted with.

BEARING INSERT TYPE YOKE SLEEVE

Large and high pressure valve may require a tremendous amount of torque to open or close the valve. Ball bearing in the yoke sleeve will reduce the operating torque of valve by up to 50 percent.

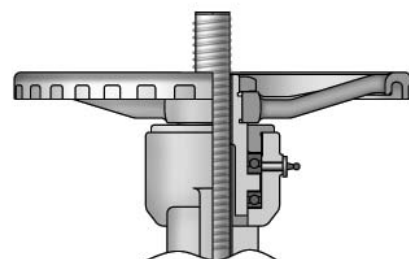

UNIT : NPS

CASS	GATE	GLOBE
600	SIZE 6 & LARGER	
900	SIZE 2, 2 1/2 & 6 LARGER	SIZE 6 & LARGER
1500	SIZE 2 & LARGER	
2500		SIZE 3 & LARGER

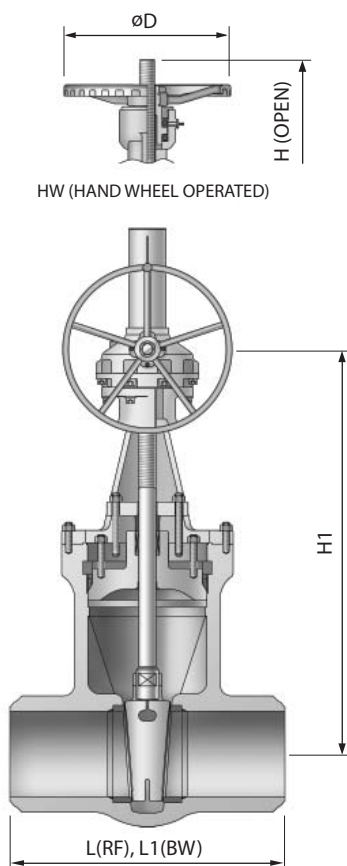

SERVICE RECOMMENDATION

1. The gate valve is normally used for on-off service.

It is not recommended for throttling.

2. The gate valve is normally installed to pipe horizontally and the valve stem stands vertically. It can also be mounted to the vertical direction with the stem facing to the opposite or other directions except the vertical, provided that a special construction is prepared depending on the valve size, service conditions, or materials. In case of valve purchase for a special purpose other than the normal installation, the orientation of valve should be specified.

3. After the gate valve is closed completely with a sufficient force enough to shut off, the stem should be backed slightly about 1/8 to 1/4 turn to relieve the load on stem. This will cause the stem to expand a little without valve bending or damage, not affecting the valve shutoff.

END CONNECTION

- R.F FLANGED ENDS TO ASME B16.5
- B.W. ENDS TO ASME B16.25
- R.T.J FLANGED ENDS TO ASME B16.5
- SIZE 26" AND LARGER, FLANGED ENDS ACCORDING TO ASME B16.47 SER.A OR SER.B

STANDARD MATERIAL SPECIFICATIONS

NO.	PART NAME	MATERIAL	
1	BODY	A216 - WCB	A217 - WC6
2	BONNET	A216 - WCB	A217 - WC6
3	WEDGE	A216 - WCB+STL	A217 - WC6+STL
4	STEM	A479 - 410	A479 - 410
5	HAND WHEEL	A53	A53
6	BODY SEAT RING	A576 - 1020+Cr(S20C)	A182 - F11+STL
7	BACK SEAT	A216 - WCB+STL	A217 - WCB+STL
8	GASKET	SOFT STEEL	304 S.S
9	PACKING	GRAPHITE+GRAPHITE WITH INCONEL WIRE	
10	GLAND FLANGE	A283 - D	A283 - D
11	GLAND BOLT	A193 - B7	A193 - B7
12	GLAND NUT	A194 - 2H	A194 - 2H
14	PACKING GLAND	A576 - 1020+Cr	A479 - 410
15	BONNET BOLT	A193 - B7	A193 - B16
16	NUT	A194 - 2H	A194 - 4
17	GEAR BOX	DUCTILE IRON	DUCTILE IRON
20	STEM PROTECTOR	A53	A53
23	YOKE	A216 - WCB	A216 - WCB
24	YOKE BOLT	A193 - B7	A193 - B7
25	NUT	A194 - 2H	A194 - 2H
27	BONNET CLAMP	A576 - 1045	A576 - 1045
28	RETAINER	A576 - 1045+Cr	A240 - 304
29	ADAPTER RING	A576 - 1045+Cr	A240 - 304
30	HAND WHEEL	A197	A197
31	YOKE CAP	A576 - 1045	A576 - 1020
32	YOKE SLEEVE	A439 - D2C	A439 - D2C

DIMENSION AND WEIGHT

CLASS 600

UNIT: mm

SIZE	2	3	4	6	8	10	12	14	15	18	20	24	26	30
L	292.1	355.6	431.8	558.8	660.4	787.4	838.2	889.0	990.6	1092.2	1193.8	1397.0	1447.8	1651
L1	177.8	254.0	304.8	457.2	584.2	711.2	812.8	889.0	990.6	1092.2	1193.8	1397.0	1447.8	1651
D	200	250	355	-	-	-	-	-	-	-	-	-	-	-
D1	-	-	-	355	500	500	630	630	710	710	800	900	900	900
H	507	588	710	-	-	-	-	-	-	-	-	-	-	-
H1	-	-	-	1160	1302	1480	1697	1825	2148	2354	2741	3042	3118	3383
WEIGHT(Kg)	29	52	121	189	339	497	758	1057	1549	2183	2763	3915	5010	7033

CLASS 900

UNIT: mm

SIZE	2	3	4	6	8	10	12	14	16	18	20	24
L	358.3	381.0	457.2	609.6	736.6	838.2	965.2	1028.7	1130.3	1219.2	1320.8	1549.4
L1	215.9	304.8	355.6	508.0	660.4	787.4	914.4	990.6	1092.2	1219.2	1320.8	1549.4
D	315	355	355	-	-	-	-	-	-	-	-	-
D1	-	-	-	500	500	630	710	710	710	900	900	900
H	586	628	740	-	-	-	-	-	-	-	-	-
H1	-	-	-	1151	1355	1626	1764	1934	2160	2512	2750	3000
WEIGHT(Kg)	33	59	110	227	349	622	922	1493	1638	2284	3577	4338

CLASS 1500

UNIT: mm

SIZE	2	3	4	6	8	10	12	14	16	18	20	24	26	30
L	368.3	469.9	546.1	704.9	831.9	990.6	1130.3	1257.3	1384.3	1536.7	1663.7	1943.1	-	2159
L1	215.9	304.8	406.4	558.8	711.2	863.6	990.6	1066.8	1193.8	1346.2	1473.2	1397.0	1473.2	2032
D	315	355	400	-	-	-	-	-	-	-	-	-	-	-
D1	-	-	-	500	630	710	710	800	900	900	900	900	900	900
H	586	712	856	-	-	-	-	-	-	-	-	-	-	-
H1	-	-	-	1065	1300	1745	1908	2040	2213	2350	2950	3218	3236	4329
WEIGHT(Kg)	40	66	121	312	458	1121	1344	1658	2064	2883	5678	5360	7015	19320

CLASS 2500

UNIT: mm

SIZE	2	3	4	6	8	10	12	14	16	18
L	450.9	577.9	573.1	914.4	1022.4	1270.0	1422.4	-	-	-
L1	279.4	368.3	457.2	609.6	762.0	914.4	1041.4	1117.6	1244.6	1397.0
D	315	355	450	-	-	-	-	-	-	-
D1	-	-	-	500	710	800	900	900	900	900
H	586	693	805	-	-	-	-	-	-	-
H1	-	-	-	1165	1500	1740	2100	2080	2540	2900
WEIGHT(Kg)	47	75	129	379	654	1276	1910	2420	3238	5944

GLOBE VALVES

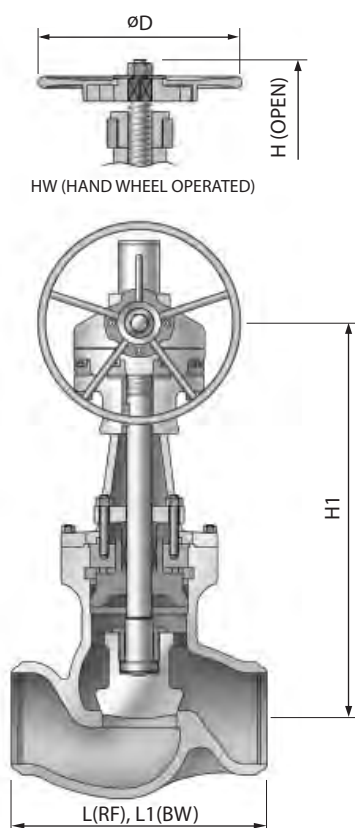

SERVICE RECOMMENDATION

1. The globe valve is normally installed with flow direction and pressure under the disc. In case the flow in valve directs to the opposite direction, always check at factory before installing the valve. Under a certain service condition, especially when a valve is equipped with cylinders or electric motor actuators, there is a cost advantage in designing and installing the valve flow over the disc. If the actuator is sized to such condition, care must be taken to install the valve correctly.

2. The globe valve is suitable for most throttling applications; however, it must not be used for a prolonged throttling at 10% open or less, which may cause excessive vibration, noise or damage to disc and seat. Use of small valves with a lower flow capacity may permit the valve to be opened to a greater percentage, and thus avoid damage. For continuous severe throttling, a control valve is required.

END CONNECTION

- R.F FLANGED ENDS TO ASME B16.5
- B.W. ENDS TO ASME B16.25
- R.T.J FLANGED ENDS TO ASME B16.5
- SIZE 26" AND LARGER, FLANGED ENDS ACCORDING TO ASME B16.47 SER.A OR SER.B

STANDARD MATERIAL SPECIFICATIONS

NO.	PART NAME	MATERIAL	
1	BODY	A216 - WCB	A217 - WC6
2	BONNET	A216 - WCB	A217 - WC6
3	DISC	A216 - WCB+STL	A217 - WC6+STL
4	STEM	A479 - 410	A479 - 410
5	HAND WHEEL	STEEL	STEEL
6	BODY SEAT	A216 - WCB+STL	A217 - WCB+STL
7	BACK SEAT	A216 - WCB+STL	A217 - WCB+STL
8	GASKET	SOFT STEEL	304 S.S
9	PACKING	GRAPHITE+GRAPHITE WITH INCONEL WIRE	
10	GLAND FLANGE	A283 - D	A283 - D
11	GLAND BOLT	A193 - B7	A193 - B7
12	GLAND NUT	A194 - 2H	A194 - 2H
14	PACKING GLAND	A576 - 1020+Cr	A479 - 410
15	BONNET BOLT	A193 - B7	A193 - B16
16	BONNET NUT	A194 - 2H	A194 - 4
17	GEAR BOX	DUCTILE IRON	DUCTILE IRON
19	LOCK NUT	A479 - 410	A479 - 410
21	YOKE	A216 - WCB	A216 - WCB
22	YOKE BOLT	A193 - B7	A193 - B7
23	YOKE NUT	A194 - 2H	A194 - 2H
25	BONNET CLAMP	A576 - 1045	A576 - 1045
26	RETAINER	A576 - 1045+Cr	A240 - 304
27	ADAPTER RING	A576 - 1045+Cr	A240 - 304
28	STEM PROTECTOR	A53	A53
29	HANDWHEEL	DUCTILE IRON	DUCTILE IRON
30	YOKE BUSH	A439 - D2C	A439 - D2C
31	HANDLE NUT	A563 - A	A563 - A

ACME threads machined accurately prolong the life of stem and bushing.

Inner row of studs establish the initial seal of the pressure seal joint.

Outer row of studs secures the yoke arm to the body.

By inserting knockout pin into a drilled hole, segmental thrust ring can be easily driven out of the retaining groove.

Stream line contour of body makes simple application and insulation cost reduction with a remarkable saving in both space and weight.

The stellited back seat area provides an accurate guide for stem.

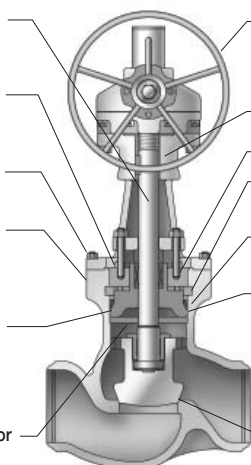

All globe valves are equipped with hammer blow type handwheels. Two integrally-cast lugs on the upper side of the handwheel strike a steel crossbar simultaneously.

Bearings for easy operation.

Gland bolts and gland shelves facilitate re-packing.

Segmental thrust ring absorbs all the thrusts applied by internal pressure.

A hardened stainless steel protective ring prevents deformation of the top portion of the soft metallic gasket.

The bonnet joint shall remain tight under all operating conditions as the sealing pressure is always much greater than the fluid pressure in the line, thereby eliminating any leakage. The higher internal pressure, the greater sealing pressure. The gasket can be removed freely without any damage to the sealed of the body.

The seat face of integral body is faced with stellite 6

DIMENSION AND WEIGHT

CLASS 600

UNIT : mm

SIZE	2	3	4	6	8	10	12	16	18
L	292.1	355.6	431.8	558.8	660.4	787.4	-	-	-
L1	177.8	254.0	304.8	457.2	584.2	711.2	812.8	990.6	1092.2
D	224	315	315	-	-	-	710	-	-
D1	-	-	-	500	560	630	-	800	900
H	406	557	556	-	-	-	1324	-	-
H1	-	-	-	802	980	1060	-	1608	2038
WEIGHT(Kg)	25	44	73	158	413	475	672	1900	2989

CLASS 900

UNIT : mm

SIZE	2	3	4	6	8	10
L	368.3	381.0	457.2	609.6	736.6	838.2
L1	215.9	304.8	355.6	508.0	660.4	787.4
D	315	315	355	-	-	-
D1	-	-	-	560	630	630
H	575	585	669	-	-	-
H1	-	-	-	894	983	1069
WEIGHT(Kg)	49	76	119	355	586	700

CLASS 1500

UNIT : mm

SIZE	2	3	4	6	8	10	12	14
L	368.3	469.9	546.1	704.9	831.9	990.6	-	-
L1	215.9	304.8	406.4	558.8	711.2	863.6	990.6	1067
D	315	355	400	-	-	-	-	-
D1	-	-	-	630	710	800	900	900
H	575	658	765	-	-	-	-	-
H1	-	-	-	850	1220	1353	1658	1858
WEIGHT(Kg)	60	91	132	420	668	934	1995	2035

CLASS 2500

UNIT : mm

SIZE	2	3	4	6	8	10
L	450.9	577.9	673.1	914.4	1022.4	1270.0
L1	279.4	368.3	457.2	609.6	762.0	914.4
D	355	400	-	-	-	-
D1	-	-	450	710	800	900
H	565	870	-	-	-	-
H1	-	-	903	1130	1278	1676
WEIGHT(Kg)	56	121	337	579	1085	1913

SWING CHECK VALVES

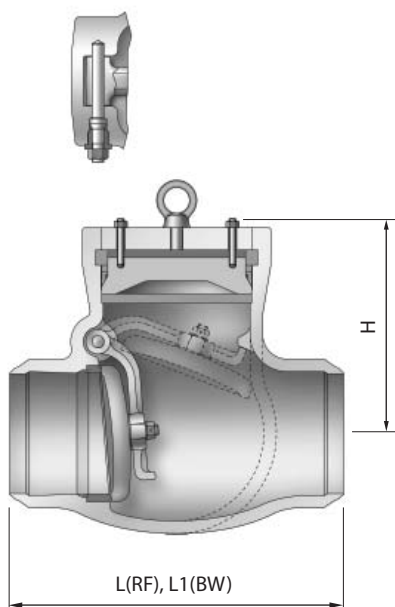

SERVICE RECOMMENDATION

1. The swing check valve shall be operated in a manner to avoid the following troubles;

1) Formation of excessive high surge pressure as a result of valve closing, and

2) Rapid fluctuating movement of valve closing member. The excessively high surge pressure by valve closing is prevented by closing the valve fast enough not to develop a significant reverse flow on a sudden shutoff which is a source of the surge pressure. Thus, the closing speed of valve should match closely with the speed of forward flow retard.

The rapid fluctuating movement of valve closing member must be avoided to prevent the moving valve parts from excessive wear which may result in early failure of valve.

Such movements can be precluded by sizing the valve to a flow rate which forces the closure member not to move.

2. The swing check valve can also be mounted to the vertical position, provided the disc should not reach the valve position. However, the closing moment of disc by weight is very low in fully-opened position, so the valve tends to close late.

In order to overcome such slow response to flow retardation, the disc may be supplied with a lever-mounted weight or with spring loaded.

STANDARD MATERIAL SPECIFICATIONS

NO.	PART NAME	MATERIAL	
1	BODY	A216 - WCB	A217 - WC6
2	BONNET	A216 - WCB	A217 - WC6
3	DISC	A216 - WCB+STL	A217 - WC6+STL
4	ARM	A216 - WCB	A217 - WC6
5	ROD PIN	A479 - 410	A479 - 410
6	BODY SEAT RING	A576 - 1020+STL(S20C)	A182 - F11+STL
7	PLLG BOLT	A307 - B	A479 - 304
8	GASKET	SOFT STEEL	304 S.S
9	PLUG GASKET	GRAPHITE	304 S.S
10	BONNET BOLT	A193 - B7	A193 - B16
11	BONNET NUT	A194 - 2H	A194 - 4
12	DISC NUT	A194 - 8	A194 - 8
13	PIN	304 S.S	304 S.S
14	WASHER	A240 - 304	A240 - 304
15	BONNET CLAMP	A576 - 1045	A576 - 1045
16	RETAINER	A576 - 1045+Cr	A240 - 304
17	ADAPTER RING	A576 - 1045+Cr	A240 - 304
18	SEALING BOLT	A479 - 410	A479 - 410
19	SEALING NUT	A194 - 2H	A194 - 2H
20	EYE BOLT	A307 - B	A307 - B

The sealing mechanism through spindle is the same construction as the pressure seal bonnet.

By inserting knockout pin into a drilled hole, segmental thrust ring can be easily driven out of the retaining groove.

The gasket can be removed freely without any damage to the sealed area of the body. The bonnet joint shall remain tight under all operating conditions as the sealing pressure is always much greater than the fluid pressure in the line, thereby eliminating any leakage. The higher internal pressure, the greater sealing pressure.

Seat rings are stellite faced and securely welded in place.

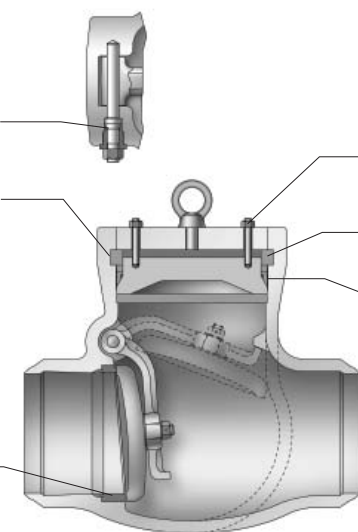

Inner row of studs establish the initial seal of the pressure seal joint.

Segmental thrust ring absorbs all the thrusts applied by internal pressure.

A hardened stainless steel protective ring prevents deformation of the top portion of the soft metallic gasket.

To ensure a secure connection between the arm and the disc nut, split pin is used.

DESIGN DATA FEATURES

1. Comply with the following standards; ASME B16.25, B16.34, MSS-SP-25, API 600 Style A.
2. The butt-welded end details of PK standard product shall be prepared in accordance with ASME B16.25

DIMENSION AND WEIGHT

CLASS 600

UNIT : mm

SIZE	2	3	4	6	8	10	12	14	16	18
L	292.1	355.6	431.8	558.8	660.4	787.4	838.2	889.0	990.6	1092.2
L1	177.8	254.0	304.8	457.2	584.2	711.2	812.8	889.0	990.6	1092.2
H	214	248	287	350	410	465	510	535	574	722
WEIGHT(kg)	34	43	48	106	217	369	503	588	798	1277

CLASS 900

UNIT : mm

SIZE	2	3	4	5	8	10	12	18	20	24
L	368.3	381.0	457.2	609.6	736.6	838.2	965.2	1219.2	1320.8	-
L1	215.9	304.8	355.6	508.0	660.4	787.4	914.4	1219.2	1320.8	1549.4
H	243	242	300	362	420	480	628	746	888	1070
WEIGHT(kg)	31	46	72	232	318	660	606	2650	3060	4010

CLASS 1500

UNIT : mm

SIZE	2	3	4	6	8	10	12	14	15	20
L	368.3	469.9	546.1	704.9	831.9	990.6	1130.3	1257.3	1384.3	1663.7
L1	215.9	304.8	406.4	558.8	711.2	863.6	990.6	1066.8	1193.8	1473.2
H	243	300	340	378	435	505	605	656	668	808
WEIGHT(kg)	34	52	90	181	346	546	828	1200	1941	3228

CLASS 2500

UNIT : mm

SIZE	2	3	4	6	8	10	12	14	18
L	450.9	577.9	673.1	914.4	1022.4	1270.0	1422.4	-	-
L1	279.4	368.3	457.2	609.6	762.0	914.4	1041.4	1117.6	1397.0
H	246	310	345	400	451	542	718	679	827
WEIGHT(kg)	32	56	92	219	460	713	1446	1568	2500

TILTING DISC CHECK VALVES

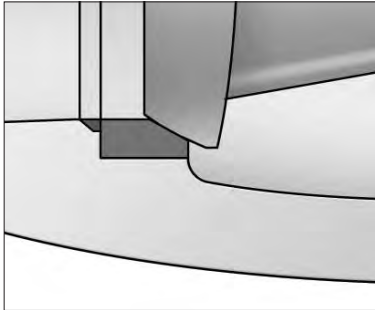

TILTING DISC CHECK ADVANTAGES

- Quick closing system
- Stability at low and pulsating flow
- Moderate pressure drop
- Tight sealing of metal seats

Seat contacts don't occur until the disc is seated and closed.

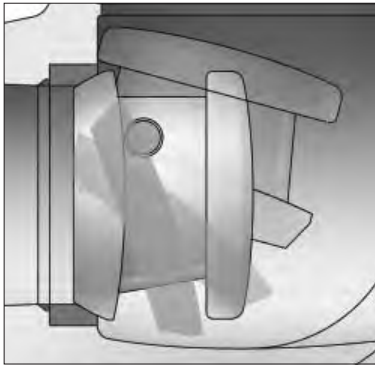

DOUBLE OFFSET

A high performance tilting disc check valve has double offset pivot (hinge pin) design.

The pivot offsets are made when constructing the valve with hinge pins which are located behind the centerline of sealing surface and slightly to one side of pipe centerline.

The offset purpose is to reduce rubbing and thus wear between seat and seal while valve is travelling.

OFFSET 1

The hinge pin is located in the centerline of disc seal surface.

OFFSET 2

The hinge pin is offset to the conical axis.

SERVICE RECOMMENDATION

1.The center of gravity of disc is very close to the axis of rotation, so that the disc can be opened or closed very quickly without damage to the body, disc or seat. Since the valve is closed quickly upon flow reversal significant fluid velocities are not developed in the reverse direction, therefore minimizing the effects of water hammer.

2.The tilting disc check valve has greater stability at low flow rates and in pulsating service when compared to a swing check valve.

3.The pressure drop across a tilting disc check will usually be much less than for an equivalent life check. Although a tilting disc check valve will restrict flow slightly more than a swing check, the straight-through flow path provides a minimal pressure drop.

4.Tilting disc check valves have moderate sealing capability and can provide tight shutoff if the differential pressure across the disc is relatively large.

Hinge pin

The hinge pins for supporting the disc are inserted through capped and gasketed bearing bosses in the outlet section of body. Sealing mechanism by hinge pins is the same as pressure seal bonnet.

Seat Ring

Seat ring is hardfaced for a long life and securely welded in place.

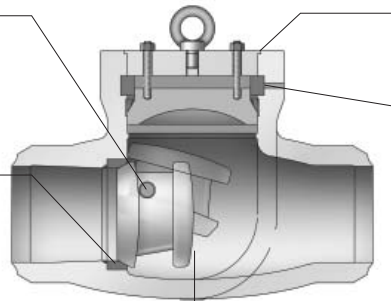

Pressure seal bonnet

A simple design has segmental retaining ring and soft steel gasket to aid disassembly and provide maximum bonnet seal.

Retainer Ring

Segmental retainer ring absorbs all the thrusts applied by internal pressure.

Disc

Conical seating has a structure of self-alignment, tightening and closing in no flow condition.

DESIGN DATA FEATURES

1. Face to face & end to end dimensions : ASME B 16.10
2. Flanged dimensions : ASME B 16.5
3. Butt welded end dimensions :ASME B 16.25
4. Valve size (if applicable) and ratings :ASME B 16.34
5. Wall thickness dimensions of valves comply with API 600

STANDARD MATERIAL SPECIFICATIONS

NO.	PART NAME	MATERIAL	
1	BODY	A216 - WCB	A216 - WC6
2	BONNET	A216 - WCB	A216 - WC6
3	DISC	A216 - WCB+STL	A217 - WC6+STL
4	HINGE PIN	A479 - 410	A479 - 410
5	BODY SEAT RING	A576 - 1020+STL	A182 - F11+STL
6	COVER	A576 - 1020	A240 - 304
7	GASKET	SOFT STEEL	304 S.S
8	COVER GASKET	GRAPHITE	304 S.S
9	BONNET BOLT	A193 - B7	A193 - B16
10	BONNET NUT	A194 - 2H	A194 - 4
11	BUSHING	A479 - 304	A479 - 304
12	BONNET CLAMP	A576 - 1045	A576 - 1045
13	RETAINER	A576 - 1045+Cr	A240 - 304
14	ADAPTER RING	A576 - 1045+Cr	A240 - 304
15	COVER BOLT	A193 - B7	A193 - B16
16	COVER NUT	A194 - 2H	A194 - 4
17	HINGE PIN NUT	A194 - 2H	A194 - 2H
18	EYE BOLT	A307 - B	A307 - B

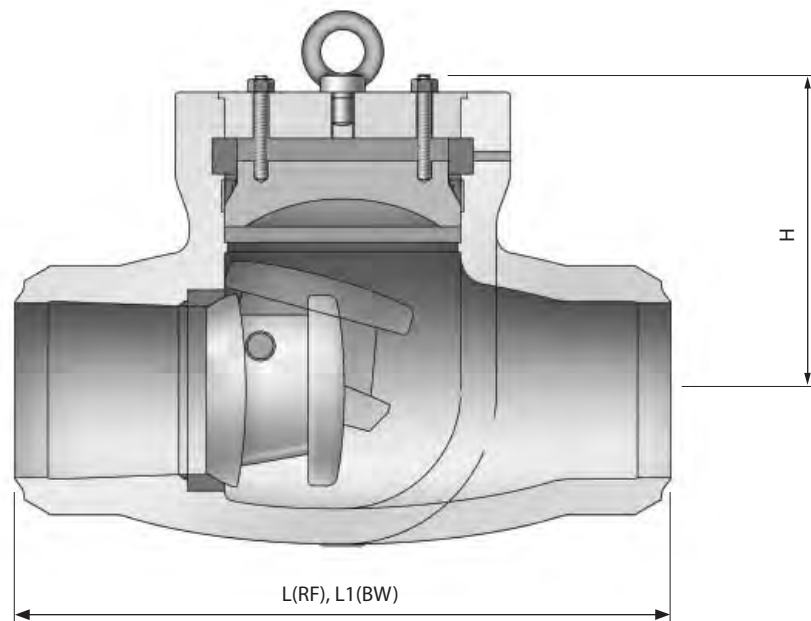

DIMENSION AND WEIGHT

CLASS 600

UNIT: mm

SIZE	2	3	4	6	20
L	292.1	355.6	431.8	558.8	1193.8
L1	177.8	254.0	304.8	457.2	1193.8
H	191	205	245	257	590
WEIGHT(kg)	41	52	58	127	-

CLASS 900

UNIT: mm

SIZE	3	4	6	8	10	12	16
L	381.0	457.2	609.6	736.6	838.2	965.2	1130.3
L1	304.8	355.6	508.0	660.4	787.4	914.4	1092.2
H	230	250	252	347	391	470	590
WEIGHT(kg)	55	86	278	382	690	727	2189

CLASS 1500

UNIT: mm

SIZE	2	3	4	6	8	10	12	14	16	18	20
L	368.3	469.9	546.1	704.9	831.9	990.6	1130.3	1257.3	1384.3	1536.7	-
L1	215.9	304.8	406.4	558.8	711.2	863.6	990.6	1066.8	1193.8	1346.2	1320
H	185	230	250	266	298	437	459	513	603	633	760
WEIGHT(kg)	41	62	108	217	415	655	994	1500	2329	2600	3060

CLASS 2500

UNIT: mm

SIZE	2	3	4	5	8	10	12	14
L	450.9	577.9	673.1	914.4	1022.4	1270.0	1422.4	-
L1	279.4	368.3	457.2	609.6	762.0	914.4	1041.4	1117.6
H	186	240	224	254	385	464	538	786
d	38.1	57.2	72.9	111.0	146.1	184.2	219.0	241.3
THK°	38	67	110	263	552	856	1735	1900

PARALLEL SLIDE GATE VALVES

- BOLTED BONNET TYPE

- PRESSURE SEAL BONNET TYPE



PARALLEL SLIDE GATE VALVE

Parallel slide gate valves are ideal for high temperature and pressure line to prevent thermal binding.

Features and benefits

Parallel slide construction can be furnished for high differential pressure services or where thermal expansion may cause sticking of a wedge type.

The parallel slide gate assembly consists of two interchangeable spring loaded discs, a fully guided disc holder, and retaining pins.

Springs are fitted between discs to provide initial sealing force only, and do not maintain the sealing force.

Discs are interchangeable which simplifies in-line maintenance and eliminates the need to custom fit the seats to the discs.

Position seating eliminates stress and potential binding due to thermal expansion of the stem.

No additional torque required to achieve a positive seal once disc are in position.

Lower seating torque to reduce actuator size and cost

Hardfaced seating surfaces provide high cycle capability in very high differential pressure services

By-pass valves are used to reduce the traversing differential pressure across the valve seat.

It reduces the size of the operating gear and also provide a convenient means for the initial warming through of pipe lines

Equalizing devices are used to relieve the fluid trapped between the seat forces, and to provide an outlet for the fluid displaced by the valve stem traversing to the shut position.

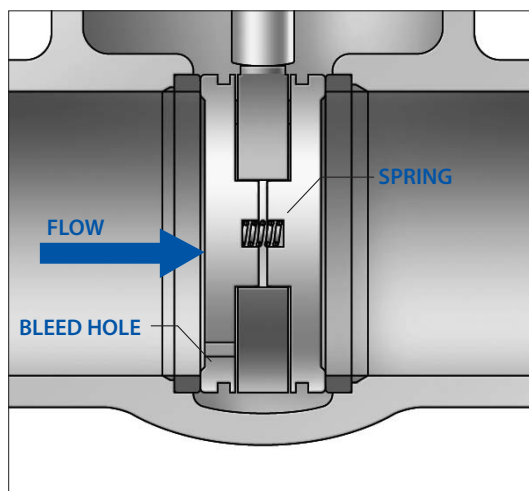



4" & SMALLER

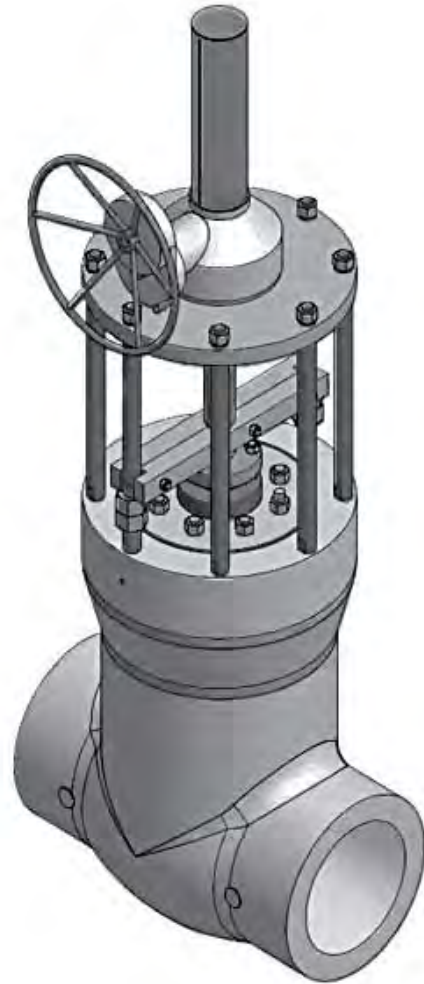

6" & LARGER



BOLTED BONNET TYPE

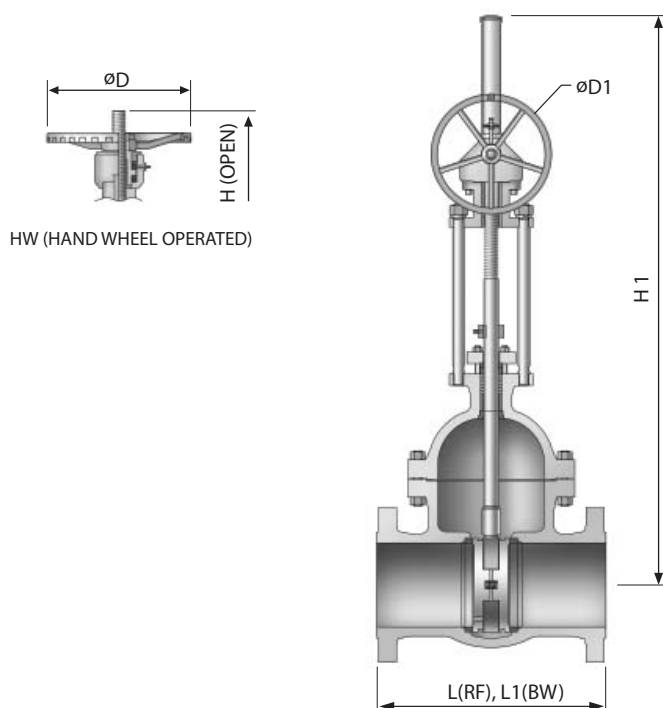

END CONNECTION

- R.F FLANGED ENDS TO ASME B16.5
- B.W. ENDS TO ASME B16.25
- R.T.J FLANGED ENDS TO ASME B16.5
- SIZE 26" AND LARGER, FLANGED ENDS ACCORDING TO ASME B16.47 SER.A OR SER.B

STANDARD MATERIAL SPECIFICATIONS

NO.	PART NAME	MATERIAL		
1	BODY	A216 - WCB	A217 - WC5	A217 - C12A
2	BONNET	A216 - WCB	A217 - WC5	A217 - C12A
3	DISC	A216 - WCB+STL	A217 - WC5+STL	A217 - C12A+STL
4	STEM	A479 - 410	A479 - 410	A479 - 410
5	HAND WHEEL	A53	A53	A53
6	BODY SEAT RING	A575 - 1020+STL	A182 - F11+STL	A182 - F91+STL
7	BACK SEAT RING	A479 - 410	A479 - 410	A479 - 410
8	GASKET	SPIRAL WOUND / GRAPHITE+304+304		
9	PACKING	GRAPHITE+GRAPHITE WITH INCONEL WIRE		
10	GLAND FLANGE	A105	A105	A105
11	GLAND BOLT	A193 - B7	A193 - B7	A193 - B7
12	GLAND NUT	A194 - 2H	A194 - 2H	A194 - 2H
13	PACKING GLAND	A575 - 1020+Cr	A479 - 410	A479 - 410
14	BONNET BOLT	A193 - B7	A193 - B16	A193 - B16
15	BONNET NUT	A194 - 2H	A194 - 4	A194 - 4
16	DISC GUIDE	A215 - WCB	A217 - WC5	A217 - C12A
17	PACKING BUSH	A479 - 410	A479 - 410	A479 - 410
18	YOKE	A283 - D	A283 - D	A283 - D
19	YOKE BAR	A575 - 1020	A576 - 1020	A575 - 1020
20	YOKE NUT	A194 - 2H	A194 - 2H	A194 - 2H
21	STOPPER	A283 - D	A283 - D	A283 - D
22	COIL SPRING	INCONEL X - 750	INCONEL X - 750	INCONEL X - 750
23	STOP BAR	A576 - 1020	A576 - 1020	A576 - 1020
24	SPRING WASHER	A575 - 1020+Zn	A576 - 1045+Zn	A576 - 1045+Zn
25	GEAR BOX	DUCTILE	DUCTILE	DUCTILE
26	STEM PROTECTOR	A53	A53	A53
27	YOKE CAP	A576 - 1020	A576 - 1020	A576 - 1020
28	YOKE SLEEVE	A439 - D2C	A439 - D2C	A439 - D2C
29	HINGE NUT	A47 - 32510+Zn	A47 - 32510+Zn	A47 - 32510+Zn
30	NIPPLE	STEEL	STEEL	STEEL

DIMENSION AND WEIGHT

CLASS 150

UNIT : mm

SIZE	2	3	4	6	8	10	12
L	177.8	203.2	228.6	266.7	292.1	330.2	355.6
L1	215.9	282.4	304.8	403.4	419.1	457.2	501.7
D	200	224	250	315	355	400	450
D1	-	-	-	-	-	-	-
H	490	590	740	1001	1252	1410	1605
H1	-	-	-	-	-	-	-
WEIGHT(Kg)	16	29	43	72	116	173	263

CLASS 300

UNIT : mm

SIZE	2	3	4	6	8	10	14	16	18	24
L	215.9	282.4	304.8	403.4	419.1	457.2	762.0	838.2	914.4	1143.0
L1	215.9	282.4	304.8	403.4	419.1	457.2	762.0	838.2	914.4	1143.0
D	200	224	250	355	400	450	-	-	-	-
D1	-	-	-	-	-	-	500	500	630	710
H	460	565	674	958	1146	1406	-	-	-	-
H1	-	-	-	-	-	-	2071	2203	2530	3220
WEIGHT(Kg)	22	41	59	119	193	291	687	876	1201	2258

CLASS 600

UNIT : mm

SIZE	2	3	4	6	8	10	12	14	16	18	20
L	292.1	355.6	431.8	558.8	650.4	787.4	838.2	889.0	990.6	1092.2	1193.8
L1	292.1	355.6	431.8	558.8	650.4	787.4	838.2	889.0	990.6	1092.2	1193.8
D	200	250	355	450	500	630	-	-	-	-	-
D1	-	-	-	-	-	500	630	630	710	710	800
H	549	650	773	1130	1258	1576	-	-	-	-	-
H1	-	-	-	-	-	1727	1921	2219	2455	2578	2855
WEIGHT(Kg)	35	64	110	222	405	626	878	1165	1490	1836	2410

PRESSURE SEAL BONNET TYPE

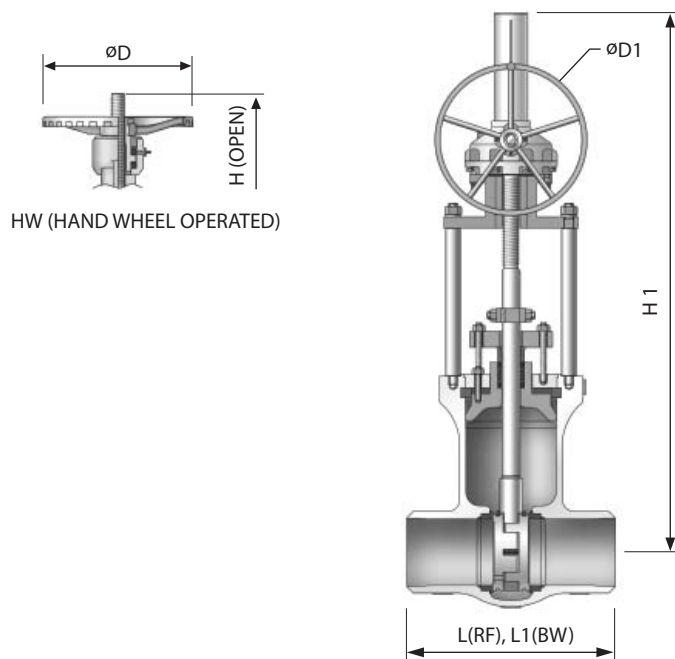

END CONNECTION

- R.F FLANGED ENDS TO ASME B16.5
- B.W. ENDS TO ASME B16.25
- R.T.J FLANGED ENDS TO ASME B16.5
- SIZE 26" AND LARGER, FLANGED ENDS ACCORDING TO ASME B16.47 SER.A OR SER.B

STANDARD MATERIAL SPECIFICATIONS

NO.	PART NAME	MATERIAL		
1	BODY	A216 - WCB	A217 - WC6	A217 - C12A
2	BONNET	A216 - WCB	A217 - WC6	A217 - C12A
3	DISC	A216 - WCB+STL	A217 - WC6+STL	A217 - C12A+STL
4	STEM	A479 - 410	A479 - 410	A479 - 410
5	HAND WHEEL	A53	A53	A53
6	BODY SEAT RING	A576 - 1020+STL	A182 - F11+STL	A182 - F91+STL
7	BACK SEAT RING	A216 - WCB	A217 - WC6+STL	A217 - C12A+STL
8	GASKET	GRAPHITE	GRAPHITE	GRAPHITE
9	PACKING	GRAPHITE+GRAPHITE WITH INCONEL WIRE		
10	GLAND FLANGE	A283 - D	A283 - D	A283 - D
11	GLAND BOLT	A193 - B7	A193 - B7	A193 - B7
12	GLAND NUT	A194 - 2H	A194 - 2H	A194 - 2H
13	YOKE	A283 - D	A283 - D	A283 - D
14	PACKING GLAND	A576 - 1020+Cr	A479 - 410	A479 - 410
15	BONNET BOLT	A193 - B7	A193 - B16	A193 - B16
16	BONNET NUT	A194 - 2H	A194 - 4	A194 - 4
17	GEAR BOX	DUCTILE IRON	DUCTILE IRON	DUCTILE IRON
18	BOLT	A193 - B7	A193 - B7	A193 - B7
19	SPRING WASHER	A576 - 1045+Zn	A576 - 1045+Zn	A576 - 1045+Zn
20	YOKE BAR	A576 - 1020	A576 - 1020	A576 - 1020
21	YOKE NUT	A194 - 2H	A194 - 2H	A194 - 2H
23	RETAINER	A576 - 1045+Cr	A240 - 304	A240 - 304
24	ADAPTER RING	A576 - 1045+Cr	A240 - 304	A240 - 304
25	DISC GUIDE	A216 - WCB	A217 - WC6	A217 - C12A
26	DISC SPRING	INCONEL X - 750	INCONEL X - 750	INCONEL X - 750
27	STOPPER	A283 - D	A283 - D	A283 - D
28	BONNET CLAMP	A576 - 1045	A576 - 1045	A576 - 1045
29	STOP BAR	A576 - 1020	A576 - 1020	A576 - 1020
30	STEM COVER	A53	A53	A53
31	YOKE CAP	A576 - 1020	A576 - 1020	A576 - 1020
32	YOKE SLEEVE	A439 - D2C	A439 - D2C	A439 - D2C
33	HINGE NUT	A47 - 32510+Zn	A47 - 32510+Zn	A47 - 32510+Zn
34	NIPPLE	STEEL	STEEL	STEEL

DIMENSION AND WEIGHT

CLASS 600

UNIT : mm

SIZE	2	3	4	6	8	10	30
L	292.1	355.6	431.8	558.8	660.4	787.4	-
L1	177.8	254.0	304.8	457.2	584.2	711.2	1651.0
D	200	250	355	450	500	630	-
D1	-	-	-	355	500	500	710
H	586	705	872	1089	1274	1520	-
H1	-	-	-	1300	1490	1720	4010
WEIGHT(Kg)	29	52	121	189	339	497	7033

CLASS 900

UNIT : mm

SIZE	2	3	4	6	8	16	24
L	368.3	381.0	457.2	609.6	736.6	1130.3	1549.4
L1	215.9	304.8	355.6	508.0	660.4	1092.2	1549.4
D	315	355	355	-	-	-	-
D1	-	-	-	500	500	500	710
H	658	773	896	-	-	-	-
H1	-	-	-	1287	1495	2542	3646
WEIGHT(Kg)	33	59	110	227	349	1638	4338

CLASS 1500

UNIT : mm

SIZE	2	3	4	6	8	10	12	14	16	18	20	26
L	368.3	469.9	545.1	704.9	831.9	990.5	1130.3	1257.3	1384.3	1536.7	1663.7	-
L1	215.9	304.8	406.4	558.8	711.2	863.6	990.6	1066.8	1193.8	1346.2	1473.2	1473.2
D	315	355	400	630	-	-	-	-	-	-	-	-
D1	-	-	-	500	630	710	710	800	900	710	710	800
H	658	832	963	1178	-	-	-	-	-	-	-	-
H1	-	-	-	1316	1497	1843	2105	2307	2655	2926	3041	3515
WEIGHT(Kg)	40	66	121	312	458	1121	1344	1658	2064	2883	5678	7015

CLASS 2500

UNIT : mm

SIZE	3	6
L	577.9	914.4
L1	368.3	609.6
D	355	630
D1	-	-
H	750	1010
H1	-	-
WEIGHT(Kg)	75	379

MEMO

Fully Integrated, Yet Flexible
PKvalve

STAINLESS STEEL VALVES

- *GATE VALVES*
- *GLOBE VALVES*
- *SWING CHECK VALVES*



STAINLESS STEEL VALVES

Stainless steel valves are utilized in the chemical, petrochemical, food, paper, and pharmaceutical processing industries all over the world.

Stainless steel valves are designed and manufactured in conformity with API, ANSI, BS and other standards recognized with quality meeting the stringent requirements for such industrial applications.

Stainless steel valves are specialized products through the processes of design, material selection, manufacturing, quality control, and experiences to final product.

PRODUCTION RANGE

UNIT: NPS

TYPE \ CLASS	150	300
GATE	1/2-24	1/2-24
GLOBE	1/2-12	1/2-12
SWING CHECK	1/2-24	1/2-24

INVESTMENT CASTING

Investment casting shall be manufactured up to 1 1/2" for class 150 and 300.

VALVE SHELL MATERIALS

Shell materials shall be in accordance with ASTM A351 Grade CF8M & CF8 and the others are optional.

ASTM DESIGNATION	MAXIMUM WORKING TEMPERATURE °F (°C)
A351 Gr. CF8	1500°F (816°C) *
A351 Gr. CF8M	1500°F (816°C) *
A351 Gr. CF3	800°F (427°C)
A351 Gr. CF3M	850°F (454°C)
A351 Gr. CF8C	1500°F (816°C) *
A351 Gr. CN7M	300°F (149°C)
A890 Gr 4A (UNS J92205)	600°F (316°C)
A890 Gr 6A (UNS J93380)	600°F (316°C)

* At temperatures over 1000°F, use the material only when the carbon contents is 0.04% or higher.

OPTIONAL BONNET FLANGE GASKET MATERIAL

Depending on service conditions, various materials are available optionally for flange gasket and stem packing.

A. Gasket materials

1. Glass fiber sheet
2. Spiral wound material (Graphite or PTFE)
3. PTFE
4. Metal ring
5. Graphite

B. Packing materials

1. PTFE
2. Graphite
3. Glass fiber sheet

DESIGN FEATURES OF PK STAINLESS STEEL GATE VALVE WEDGES

PK adopts an H-shaped flexible wedge of which the size is 3" and larger for Class 150 and 2" and higher for Class 300/600. The H-shaped flexible wedges are featured with mechanical flexibility to be able to adjust to the shape of body seat for secure mutual contacts.

It has a particular importance when large gate valve is applied to extremely high pressure and temperature that temporary deformation may occur in valve all the time.

If the H-shape wedge is provided, operating torque would get smaller, seat wear less, and valve closing tighter.

UNIT : NPS

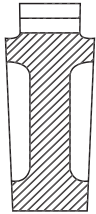
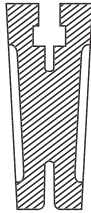
	ONE PIECE SOLID WEDGE	FLEXIBLE ONE PIECE WEDGE
CLASS		
150	2 1/2 & SMALLER	3 & LARGER
300	1 & SMALLER	1 1/2 & LARGER
600	-	2 & LARGER

DESIGN FEATURES OF GLOBE VALVE DISC

Globe valve adopts plug type disc. The bottom guide type plug disc shall be applied following the range shown below.

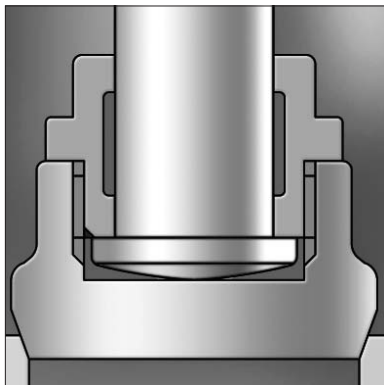

PLUG DISC

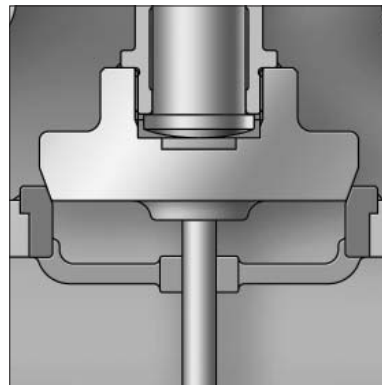

BOTTOM GUIDE
TYPE
PLUG DISC

UNIT : NPS

CLASS	SIZE
150	10 AND LARGER
300	8 AND LARGER

DESIGN FEATURES OF GATE VALVE YOKE SLEEVE

It is manufactured by two different ways depending on the valve size.



TYPE A

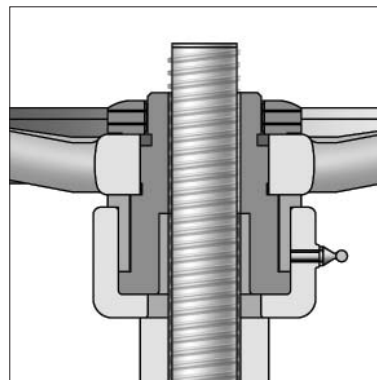

TYPE B

UNIT : NPS

TYPE A	TYPE B
5 AND SMALLER	6 AND LARGER

Yoke caps type B is made of CS 1020+Zn plating.

DESIGN FEATURES OF GATE VALVE YOKE

On 10" and smaller valves, the yoke is integrated with bonnet.

On 12" and larger valves, the yoke is separated from bonnet.

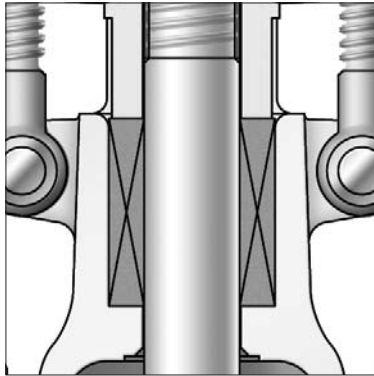

INTEGRAL YOKE

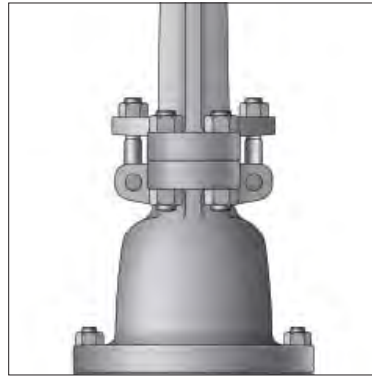

SEPARATE YOKE

DESIGN FEATURES OF VALVE BONNET BOLTS

It is manufactured by two different ways depending on valve class and size.

UNIT: NPS

	CLASS	SIZE	BOLT
Type A	150	5 AND SMALLER	HEX. HEAD
	300	2 1/2 AND SMALLER	
Type B	150	6 AND LARGER	FULL THREAD. BOLT & NUT
	300	3 AND LARGER	

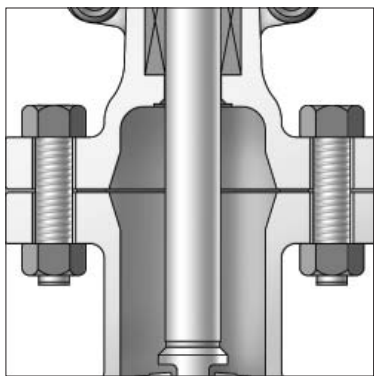

TYPE A
HEX. HEADED BOLT

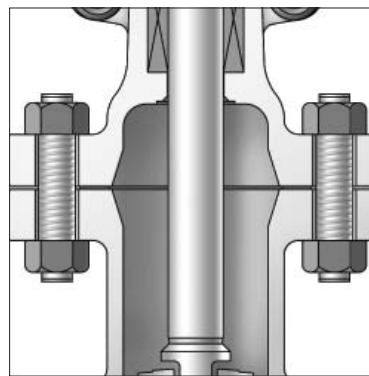

TYPE B
STUD BOLT

DESIGN FEATURES OF VALVE HAND WHEELS

Hand wheels are made in accordance with ASTM A 197 for external dimension 560mm and ASTM A216 WCB for over 560mm. A hammer blow type hand wheel of ASTM A216 WCB is provided for Class 150 (size 8) valves and Class 300 and over valves (size 6")

GATE VALVES

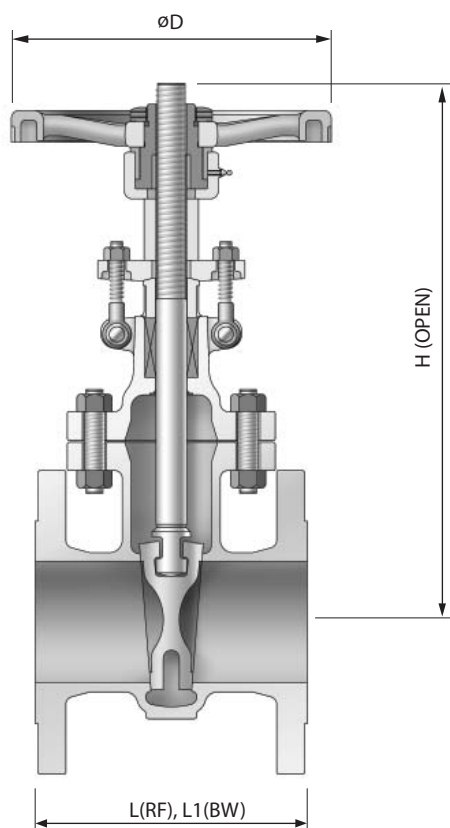

STANDARD MATERIAL SPECIFICATIONS

NO.	PART NAME	MATERIAL	
1	BODY	A351 - CF8	A351 - CF8M
2	BONNET	A351 - CF8	A351 - CF8M
3	WEDGE	A351 - CF8	A351 - CF8M
4	STEM	A479 - 304	A479 - 316
5	HAND WHEEL	A197	A197
6	BODY SEAT	A351 - CF8	A351 - CF8M
7	BACK SEAT	A351 - CF8	A351 - CF8M
8	GASKET	SPIRAL WOUND / GRAPHITE+316+316	
9	PACKING	GRAPHITE+GRAPHITE WITH INCONEL WIRE	
10	GLAND FLANGE	A351 - CF8	A351 - CF8
11	HINGE BOLT	A193 - B8	A193 - B8
12	HINGE NUT	A194 - 8	A194 - 8
13	HINGE PIN	A479 - 304	A479 - 304
14	PACKING GLAND	A479 - 304	A479 - 316
15	BONNET BOLT	A193 - B8	A193 - B8
16	BONNET NUT	A194 - 8	A194 - 8
17	YOKE CAP	A576 - 1020+Zn	A576 - 1020+Zn
18	YOKE SLEEVE	A439 - D2C	A439 - D2C
19	HANDLE NUT	304 S.S	304 S.S
20	SET SCREW	STEEL+ Cr	STEEL+ Cr
21	NIPPLE	STEEL+ Cr	STEEL+ Cr

END CONNECTION - R.F FLANGED ENDS TO ASME B16.5
 - B.W. ENDS TO ASME B16.25
 - R.T.J FLANGED ENDS TO ASME B16.5
 - CONSULT US FOR LARGER SIZE

DIMENSION AND WEIGHT

CLASS 150

UNIT : mm

SIZE	1/2	3/4	1	1 1/2	2	2 1/2	3	4	6	8	10	12
L	108.0	117.3	127.0	165.1	177.8	190.5	203.2	228.6	266.7	292.1	330.2	355.6
L1	108.0	117.3	127.0	165.1	215.9	214.3	282.4	304.8	403.4	419.1	457.2	501.7
D	120	120	120	140	160	160	200	250	315	355	355	400
H	208	208	226	285	333	384	424	531	730	938	1114	1317
WEIGHT(kg)	6	6	6	9	12	18	23	35	62	102	147	213

CLASS 300

UNIT : mm

SIZE	1/2	3/4	1	1 1/2	2	2 1/2	3	4	6	8	10	12
L	139.7	152.4	165.1	190.5	215.9	241.3	282.4	304.8	403.4	419.1	457.2	501.7
L1	139.7	152.4	165.1	190.5	215.9	241.3	282.4	304.8	403.4	419.1	457.2	501.7
D	120	120	120	200	200	200	224	250	355	400	450	500
H	208	211	279	306	346	388	447	542	758	949	1152	1417
WEIGHT(kg)	8	8	8	16	18	29	39	54	112	202	253	390

GLOBE VALVES

STANDARD MATERIAL SPECIFICATIONS

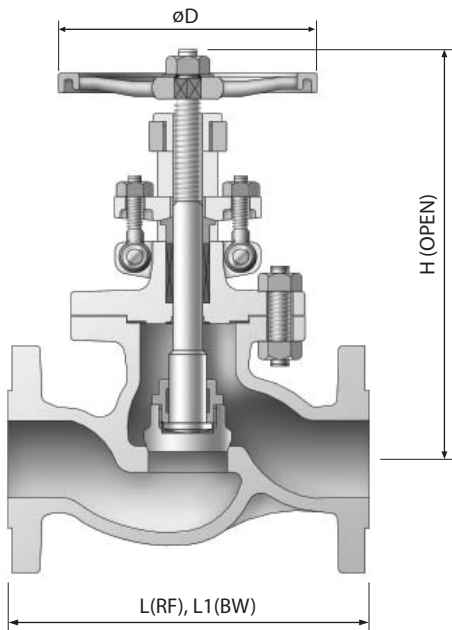

NO.	PART NAME	MATERIAL	
1	BODY	A351 - CF8	A351 - CF8M
2	BONNET	A351 - CF8	A351 - CF8M
3	DISC	A351 - CF8	A351 - CF8M
4	STEM	A479 - 304	A479 - 316
5	HAND WHEEL	A197	A197
6	BODY SEAT	A351 - CF8	A351 - CF8M
7	BACK SEAT	A351 - CF8	A351 - CF8M
8	GASKET	SPIRAL WOUND / GRAPHITE+316+316	
9	PACKING	GRAPHITE+GRAPHITE WITH INCONEL WIRE	
10	GLAND FLANGE	A351 - CF8	A351 - CF8
11	HINGE BOLT	A193 - B8	A193 - B8
12	HINGE NUT	A194 - 8	A194 - 8
13	HINGE PIN	A479 - 304	A479 - 304
14	PACKING GLAND	A479 - 304	A479 - 316
15	BONNET BOLT	A193 - B8	A193 - B8
16	BONNET NUT	A194 - 8	A194 - 8
17	YOKE BUSH	A439 - D2C	A439 - D2C
18	LOCK NUT	A479 - 304	A479 - 316
19	HANDLE NUT	A194 - 8	A194 - 8
20	WASHER	304 S.S	304 S.S

- END CONNECTION**
- R.F FLANGED ENDS TO ASME B16.5
 - B.W. ENDS TO ASME B16.25
 - R.T.J FLANGED ENDS TO ASME B16.5
 - CONSULT US FOR LARGER SIZE

DIMENSION AND WEIGHT

CLASS 150

UNIT : mm

SIZE	1/2	3/4	1	1 1/2	2	2 1/2	3	4	6	8	10	12
L	108.0	117.3	127.0	165.1	203.2	215.9	241.3	292.1	406.4	495.3	622.3	698.5
L1	108.0	117.3	127.0	165.1	203.2	215.9	241.3	292.1	406.4	495.3	622.3	698.5
D	100	100	140	160	160	200	224	280	355	355	400	400
H	174	174	224	259	266	281	342	377	429	558	740	803
WEIGHT(kg)	4	4	4	10	13	21	27	42	76	149	241	395

CLASS 300

UNIT : mm

SIZE	1/2	3/4	1	1 1/2	2	2 1/2	3	4	6	8	10	12
L	152.4	177.8	203.2	228.6	266.7	292.1	317.5	355.6	444.5	558.8	622.3	711.2
L1	152.4	177.8	203.2	228.6	266.7	292.1	317.5	355.6	444.5	558.8	622.3	711.2
D	100	100	140	160	160	200	224	280	355	400	450	500
H	185	194	224	267	329	354	383	443	567	625	881	989
WEIGHT(kg)	9	9	9	15	17	33	34	46	125	218	367	521

SWING CHECK VALVES

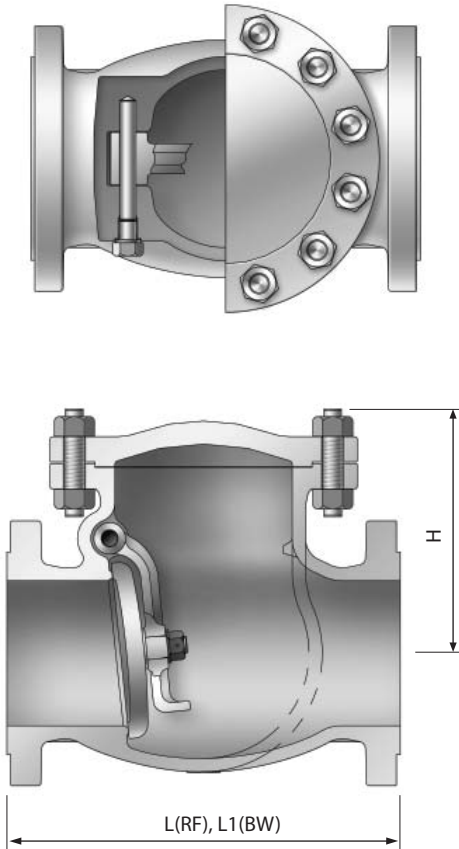

STANDARD MATERIAL SPECIFICATIONS

NO.	PART NAME	MATERIAL	
1	BODY	A351 - CF8	A351 - CF8M
2	BONNET	A351 - CF8	A351 - CF8M
3	DISC	A351 - CF8	A351 - CF8M
4	ARM	A351 - CF8	A351 - CF8M
5	ROD PIN	A479 - 304	A479 - 304
6	BODY SEAT RING	A351 - CF8	A351 - CF8M
7	PLUG BOLT	A479 - 304	A479 - 304
8	GASKET	SPIRAL WOUND / GRAPHITE+316+316	
9	PLUG GASKET	304 S.S	304 S.S
10	BONNET BOLT	A193 - B8	A193 - B8
11	BONNET NUT	A194 - 8	A194 - 8
12	DISC NUT	A194 - 8	A194 - 8M
13	PIN	304 S.S	304 S.S
14	WASHER	A240 - 304	A240 - 304

END CONNECTION

- R.F FLANGED ENDS TO ASME B16.5
- B.W. ENDS TO ASME B16.25
- R.T.J FLANGED ENDS TO ASME B16.5
- CONSULT US FOR LARGER SIZE

DIMENSION AND WEIGHT

CLASS 150

UNIT: mm

SIZE	1/2	3/4	1	1 1/2	2	2 1/2	3	4	6	8	10	12
L	108.0	117.3	127.0	165.1	203.2	215.9	241.3	292.1	355.6	495.3	622.3	698.5
L1	108.0	117.3	127.0	165.1	203.2	215.9	241.3	292.1	355.6	495.3	622.3	698.5
H	85	89	102	120	138	155	160	201	248	293	330	354
WEIGHT(kg)	5	5	5	11	13	18	22	36	62	119	155	235

CLASS 300

UNIT: mm

SIZE	1/2	3/4	1	1 1/2	2	2 1/2	3	4	5	8	10	12
L	152.4	177.8	215.9	241.3	266.7	292.1	317.5	355.6	444.5	533.4	622.3	711.2
L1	152.4	177.8	215.9	241.3	266.7	292.1	317.5	355.6	444.5	533.4	622.3	711.2
H	93	96	112	126	152	164	176	186	262	312	355	393
WEIGHT(kg)	10	10	10	14	19	25	33	53	109	199	231	308

CRYOGENIC VALVES

- *GATE VALVES*
- *GLOBE VALVES*
- *SWING CHECK VALVES*
- *BUTTERFLY VALVES*



CRYOGENIC VALVES

CRYOGENIC SERVICE VALVES

Cryogenic valves are specially engineered and designed for piping systems used in the storage and transport of liquefied gasses such as LNG and liquid nitrogen and oxygen. The main structural feature of these valves is an extended bonnet with an enclosed vapor chamber to isolate packing from the cryogenic fluid and thereby allow packing to function properly. PK Valve Cryogenic designs and liquid nitrogen testing facilities go much further to assure proven performance in this most demanding application.

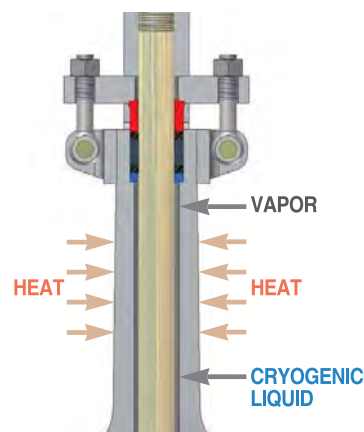

MATERIAL

Materials suitable for working condition must be adopted for low temperature valves.

Especially in petrochemical industry, the types of fluids to be processed are different according to each section even in the same plants.

At the same time, the temperatures used are also different. A full consideration must be paid to the selection of material.

BODY AND BONNET

As for the materials constituting the low temperature valves, special consideration must be paid to the materials used at pressure parts as in the case of body and bonnet.

BODY MATERIAL	SERVICE TEMPERATURE		BOLT	NUT
	°F	°C		
CARBON STEEL(GRADE LCB)	-50	-46	A320 GR. L7	A194 GR. 4
C-1/2Mo(GRADE LC1)	-75	-59	A320 GR. L7	A194 GR. 4
2 1/2NI(GRADE LC2)	-100	-73	A320 GR. L7	A194 GR. 4
3 1/2NI(GRADE LC3)	-150	-101	A320 GR. L7	A194 GR. 4
TYPE 304(GRADE CF8)	-425	-254	A320 GR. B8	A194 CR. 8
TYPE 304(GRADE CF3)	-425	-254	A320 GR. B8	A194 CR. 8
TYPE 316(GRADE CF8M)	-425	-254	A320 GR. B8	A194 CR. 8
TYPE 316L(GRADE CF3M)	-425	-254	A320 GR. B8	A194 CR. 8

TRIM

Following the body and bonnet, selection of materials for main parts such as stem, seat ring, and gland is very important. We adopt austenite stainless steel.

PACKING

Teflon or other plastic packing protecting from shrinkage by large column of insulating gas.

SEATING SURFACE

Stellite 6 for all medium and high pressure application prevents seizing and galling.

BOLT AND NUT

Material for bolts at low temperatures requires especially strength. Therefore, rigidity at low temperature is demanded and brittleness at low temperature of steel material can be improved generally by heat treatment. We use it according to ASTM standard.

TABLE OF LIQUEFIED GASSES

TYPE	BOILING POINT	
	°F	°C
NATURAL GAS, LNG	-270	-168
METHANE, CH ₄	-258	-162
OXYGEN, O ₂	-296	-183
ARGON, AR	-303	-186
CARBON DIOXIDE, CO ₂	-314	-192
NITROGEN, N ₂	-320	-196
HYDROGEN, H ₂	-423	-253
HELIUM, HE	-452	-269

PRODUCTION MATERIALS

ASTM : A351-CF8, CF8M, CF3, CF3M or Equivalent

UNIT : NPS

CLASS TYPE	150	300	600	900	1500
GATE	2-60	2-48	2-36	2-24	2-16
GLOBE	2-24	2-24	2-14	2-14	2-10
SWING CHECK	2-48	2-36	2-36	2-24	2-16
BUTTERFLY	3-48				

GATE VALVES

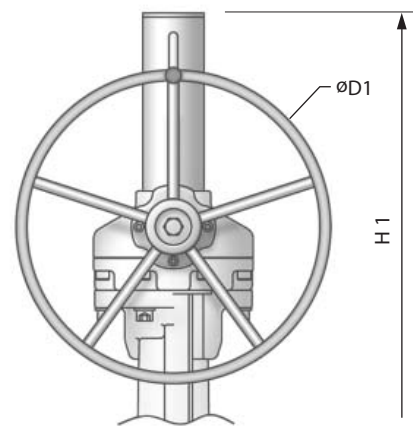
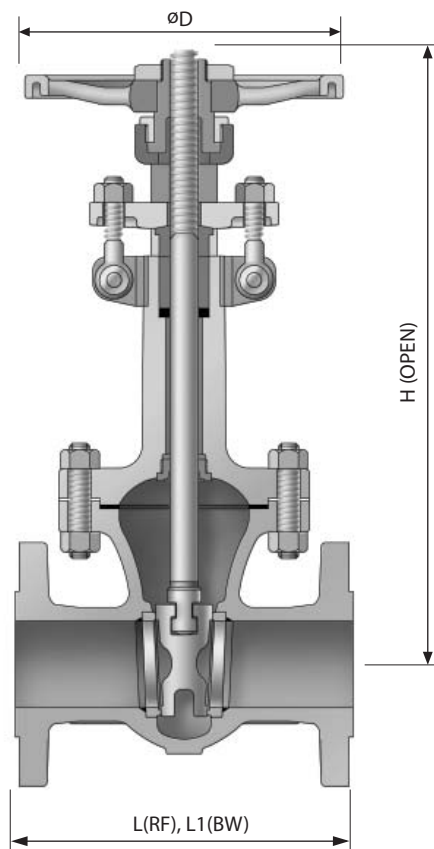

GOV (GEAR OPERATED)

END CONNECTION

- R.F FLANGED ENDS TO ASME B16.5
- B.W. ENDS TO ASME B16.25
- R.T.J FLANGED ENDS TO ASME B16.5
- SIZE 26" AND LARGER, FLANGED ENDS ACCORDING TO ASME B16.47 SER.A OR SER.B
- CONSULT US FOR LARGER SIZE

STANDARD MATERIAL SPECIFICATIONS

NO.	PART NAME	MATERIAL	
1	BODY	A351 - CF8	A351 - CF8M
2	BONNET	A351 - CF8	A351 - CF8M
3	WEDGE	A351 - CF8+STL	A351 - CF8M+STL
4	STEM	A479 - 304	A479 - 316
5	HAND WHEEL	A197	A197
6	BODY SEAT RING	A240 - 304+ STL	A240 - 316+STL
7	BACK SEAT RING	A479 - 304	A479 - 316
8	GASKET	SPIRAL WOUND / GRAPHITE+316+316	
9	PACKING	GRAPHITE+GRAPHITE WITH INCONEL WIRE	
10	GLAND FLANGE	A351 - CF8	A351 - CF8
11	HINGE BOLT	A193 - B8	A193 - B8
12	HINGE NUT	A194 - 8	A194 - 8
13	HINGE PIN	A479 - 304	A479 - 304
14	PACKING GLAND	A479 - 304	A479 - 316
15	BONNET BOLT	A320 - B8 CL.2	A320 - B8 CL.2
16	BONNET NUT	A194 - 8	A194 - 8
17	YOKE CAP	304 S.S	304 S.S
18	YOKE SLEEVE	AL-BRONZE	AL-BRONZE
19	HANDLE NUT	A47 - 32510+Zn	A47 - 32510+Zn
20	SET SCREW	STEEL+ Cr	STEEL+ Cr
21	NIPPLE	STEEL+ Cr	STEEL+ Cr
22	YOKE	A351 - CF8	A351 - CF8
23	STUFFING RING	A479 - 304	A479 - 316
24	GEAR BOX	DUCTILE IRON	DUCTILE IRON
25	STEM COVER	A53	A53

DIMENSION AND WEIGHT

CLASS 150

UNIT : mm

SIZE	2	3	4	6	8	10	12	14	16	18	24	28	30
L	177.8	203.2	228.6	266.7	292.1	330.2	355.6	381.0	406.4	431.8	1143.0	1346.2	1397.0
L1	215.9	282.5	304.8	403.4	419.1	457.2	501.7	571.5	609.6	660.4	1143.0	1346.2	1397.0
D	200	224	250	355	355	355	-	-	-	-	-	-	-
D1	-	-	-	250	250	355	355	355	500	500	710	800	800
H	653	763	844	1045	1222	1458	-	-	-	-	-	-	-
H1	-	-	-	1175	1323	1587	1835	2080	2314	2350	2986	3552	3716

CLASS 300

UNIT : mm

SIZE	2	3	4	5	8	10	12	14	16	18	20	24	28
L	215.9	282.4	304.8	403.4	419.1	457.2	501.7	762.0	838.2	914.4	990.6	1143.0	1346.2
L1	215.9	282.4	304.8	403.4	419.1	457.2	501.7	762.0	838.2	914.4	990.6	1143.0	1346.2
D	200	224	250	355	400	450	-	-	-	-	-	-	-
D1	-	-	-	250	355	355	355	500	500	630	630	710	800
H	676	766	851	1021	1278	1479	-	-	-	-	-	-	-
H1	-	-	-	1154	1457	1602	1853	1980	2316	2393	2663	2986	3552

CLASS 600

UNIT : mm

SIZE	2	3	4	6	8	10	12	14	16	18	20	26
L	292.1	355.6	431.8	558.8	660.4	787.4	838.2	889.0	990.6	1092.2	1193.8	1447.8
L1	292.1	355.6	431.8	558.8	660.4	787.4	838.2	889.0	990.6	1092.2	1193.8	1447.8
D	200	250	355	450	500	-	-	-	-	-	-	-
D1	-	-	-	355	500	500	630	630	710	710	800	900
H	674	785	879	1084	1326	-	-	-	-	-	-	-
H1	-	-	-	1213	1506	1628	1883	2014	2214	2445	2680	3320

CLASS 900

UNIT : mm

SIZE	2	3	4	6	8	10	12	14	16	18	20	24
L	368.3	381.0	457.2	609.6	736.6	838.2	965.2	1028.7	1130.3	1219.2	1320.8	1549.4
L1	368.3	381.0	457.2	609.6	736.6	838.2	965.2	1028.7	1130.3	1219.2	1320.8	1549.4
D	250	355	355	500	630	710	-	-	-	-	-	-
D1	-	250	250	500	500	630	710	710	710	900	900	900
H	595	802	928	1231	1393	1691	-	-	-	-	-	-
H1	-	-	1033	1327	1558	1813	1924	2020	2251	2509	2655	3178

CLASS 1500

UNIT : mm

SIZE	3	6
L	469.9	704.9
L1	469.9	704.9
D	-	-
D1	250	400
H	-	-
H1	950	1480

GLOBE VALVES

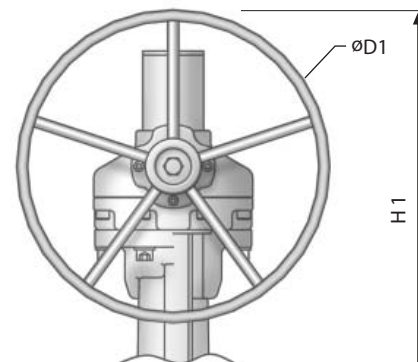
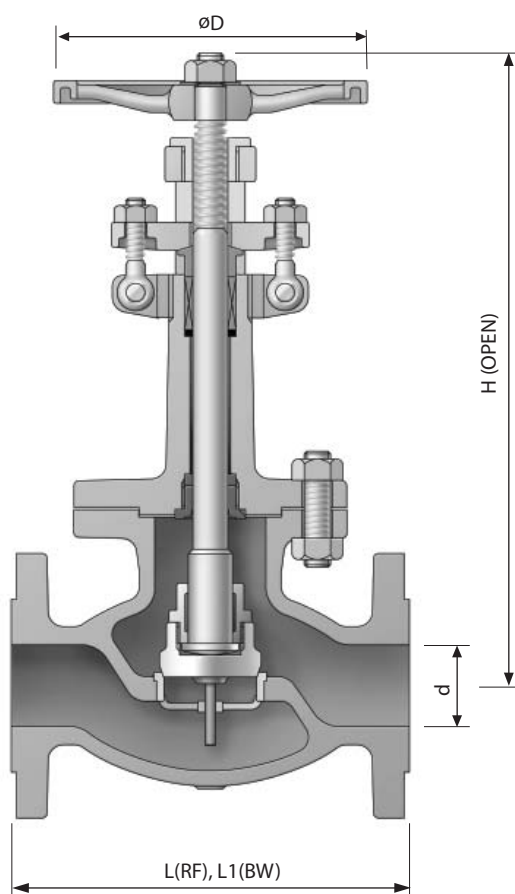

GOV (GEAR OPERATED)

END CONNECTION

- R.F FLANGED ENDS TO ASME B16.5
- B.W. ENDS TO ASME B16.25
- R.T.J FLANGED ENDS TO ASME B16.5
- SIZE 26" AND LARGER, FLANGED ENDS ACCORDING TO ASME B16.47 SER.A OR SER.B
- CONSULT US FOR LARGER SIZE

STANDARD MATERIAL SPECIFICATIONS

NO.	PART NAME	MATERIAL	
1	BODY	A351 - CF8	A351 - CF8M
2	BONNET	A351 - CF8	A351 - CF8M
3	DISC	A351 - CF8+STL	A351 - CF8M+STL
4	STEM	A479 - 304	A479 - 316
5	HAND WHEEL	A197	A197
6	BODY SEAT RING	A351 - CF8+ STL	A351 - CF8M+STL
7	BACK SEAT RING	A479 - 304	A479 - 316
8	GASKET	SPIRAL WOUND / GRAPHITE+316+316	
9	PACKING	GRAPHITE+GRAPHITE WITH INCONEL WIRE	
10	GLAND FLANGE	A351 - CF8	A351 - CF8
11	HINGE BOLT	A193 - B8	A193 - B8
12	HINGE NUT	A194 - 8	A194 - 8
13	HINGE PIN	A479 - 304	A479 - 304
14	PACKING GLAND	A479 - 304	A479 - 316
15	BONNET BOLT	A320 - B8 CL.2	A320 - B8 CL.2
16	BONNET NUT	A194 - 8	A194 - 8
17	YOKE BUSH	AL-BRONZE	AL-BRONZE
18	LOCK NUT	A479 - 304	A479 - 316
19	HANDLE NUT	A194 - 8	A194 - 8
20	WASHER	A240 - 304	A240 - 304
21	YOKE	A351 - CF8	A351 - CF8
22	STUFFING RING	A479 - 304	A479 - 316
23	GEAR BOX	DUCTILE IRON	DUCTILE IRON
24	STEM COVER	A53	A53

DIMENSION AND WEIGHT

CLASS 150

UNIT : mm

SIZE	2	3	4	6	8	10	12	14	18
L	203.2	241.3	292.1	406.4	495.3	622.3	698.5	787.4	978.0
L1	203.2	241.3	292.1	406.4	495.3	622.3	698.5	787.4	978.0
D	200	250	315	355	355	400	400	-	-
D1	-	-	-	350	450	450	500	560	630
H	573	655	693	816	990	-	-	-	-
H1	-	-	-	1094	1056	1148	1266	1358	1891

CLASS 300

UNIT : mm

SIZE	2	3	4	6	8	10	12	14
L	266.7	317.5	355.6	444.5	558.8	622.3	711.2	838.2
L1	266.7	317.5	355.6	444.5	558.8	622.3	711.2	838.2
D	200	250	315	355	400	450	-	-
D1	-	-	-	450	500	560	630	630
H	621	713	773	894	1047	1192	-	-
H1	-	-	-	1159	1156	1400	1638	1627

CLASS 600

UNIT : mm

SIZE	2	3	4	6	8
L	292.1	355.6	431.8	558.8	660.4
L1	292.1	355.6	431.8	558.8	660.4
D	224	315	315	450	-
D1	-	-	-	500	560
H	607	692	776	-	-
H1	-	-	-	1176	1426

CLASS 900

UNIT : mm

SIZE	2	3	4	6	8
L	368.3	381.0	457.2	609.6	736.6
L1	368.3	381.0	457.2	609.6	736.6
D	315	315	355	450	710
D1	-	-	-	560	630
H	688	737	882	-	-
H1	-	-	-	1488	1789

CLASS 1500

UNIT : mm

SIZE	2	3
L	368.3	469.9
L1	368.3	469.9
D	315	355
D1	-	-
H	688	798
H1	-	-

SWING CHECK VALVES

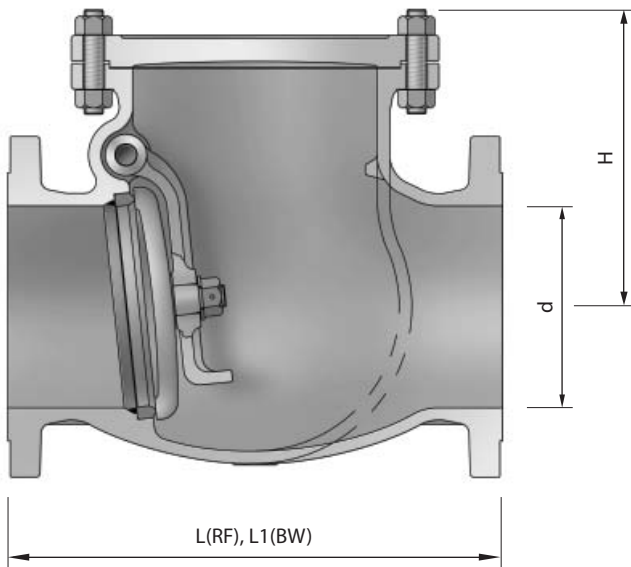
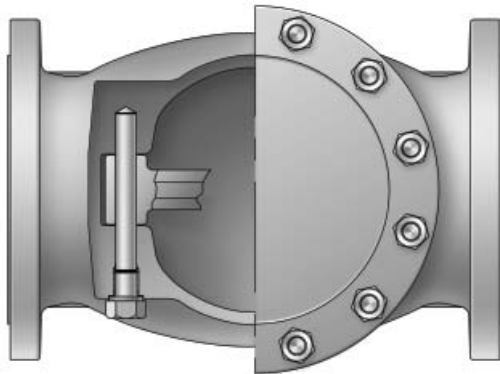

END CONNECTION

- R.F FLANGED ENDS TO ASME B16.5
- B.W. ENDS TO ASME B16.25
- R.T.J FLANGED ENDS TO ASME B16.5
- SIZE 26" AND LARGER, FLANGED ENDS ACCORDING TO ASME B16.47 SER.A OR SER.B
- CONSULT US FOR LARGER SIZE

STANDARD MATERIAL SPECIFICATIONS

NO.	PART NAME	MATERIAL	
1	BODY	A351 - CF8	A351 - CF8M
2	BONNET	A351 - CF8	A351 - CF8M
3	DISC	A351 - CF8M+STL	A351 - CF8M+STL
4	ARM	A351 - CF8	A351 - CF8M
5	ROD PIN	A479 - 304	A479 - 316
6	BODY SEAT RING	A240+304+STL	A240+316+STL
7	PLUG BOLT	A479 - 304	A479 - 316
8	GASKET	SPIRAL WOUND / GRAPHITE+316+316	
9	PLUG GASKET	304 S.S	316 S.S
10	BONNET BOLT	A320 - B8 CL.2	A320 - B8 CL.2
11	BONNET NUT	A194 - 8	A194 - 8
12	DISC NUT	A194 - 8	A194 - 8M
13	PIN	304 S.S	316 S.S
14	WASHER	340 S.S	315 S.S

DIMENSION AND WEIGHT

CLASS 150

UNIT : mm

SIZE	2	3	4	6	8	10	12	14	16	18	20	24	26	28	30
L	203.2	241.3	292.1	355.6	495.3	622.3	698.5	787.4	863.6	977.9	977.9	1295.4	1295.4	1447.8	1524
L1	203.2	241.3	292.1	355.6	495.3	622.3	698.5	787.4	863.6	977.9	977.9	1295.4	-	-	-
H	160	190	225	260	320	350	380	405	460	505	570	680	865	918	962
WEIGHT(kg)	16	26	45	78	136	214	319	412	514	749	933	1346	1727	1964	2247

CLASS 300

UNIT : mm

SIZE	2	3	4	6	8	10	12	14	16	18	20	24	26	28	30
L	266.7	317.5	355.6	444.5	533.4	622.3	711.2	838.2	863.6	977.9	1016.0	1346.2	1346.2	1498.6	1593.9
L1	266.7	317.5	355.6	444.5	533.4	622.3	711.2	838.2	863.6	977.9	1016.0	1346.2	-	-	-
H	160	199	227	278	322	383	435	510	521	572	622	712	979	983	1115
WEIGHT(kg)	21	42	64	124	222	291	444	632	786	1058	1210	1916	2000	2600	3664

CLASS 600

UNIT : mm

SIZE	2	3	4	6	8	10	12	14	16	18	20	24	26	30
L	292.1	355.6	431.8	558.8	660.4	787.4	838.2	889.0	990.6	1092.2	1193.8	1397.0	-	1651
L1	292.1	355.6	431.8	558.8	660.4	787.4	838.2	889.0	990.6	1092.2	1193.8	1397.0	1448	-
H	197	210	256	329	364	464	486	572	660	711	787	864	1028	1135
WEIGHT(kg)	31	56	103	204	342	624	776	938	1250	1518	2390	3686	4000	5502

CLASS 900

UNIT : mm

SIZE	2	3	4	6	8	10	12	14	16	18	20	24
L	368.3	381.0	457.2	609.6	736.6	838.2	965.2	1028.7	1130.3	1219.2	1320.8	1549.4
L1	368.3	381.0	457.2	609.6	736.6	838.2	965.2	1028.7	1130.3	1219.2	1320.8	1549.4
H	267	290	306	338	460	500	578	647	710	785	850	1006
WEIGHT(kg)	68	106	139	294	525	731	1025	1444	1850	2610	3407	5842

CLASS 1500

UNIT : mm

SIZE	2	3	4	6	8	10	12	16
L	368.3	469.9	546.1	704.9	831.9	990.6	1130.3	1384.3
L1	368.3	439.9	546.1	704.9	831.9	990.6	1130.3	1384.3
H	267	296	355	465	540	657	728	1116
WEIGHT(kg)	73	125	212	470	825	960	1510	4630

BUTTERFLY VALVES

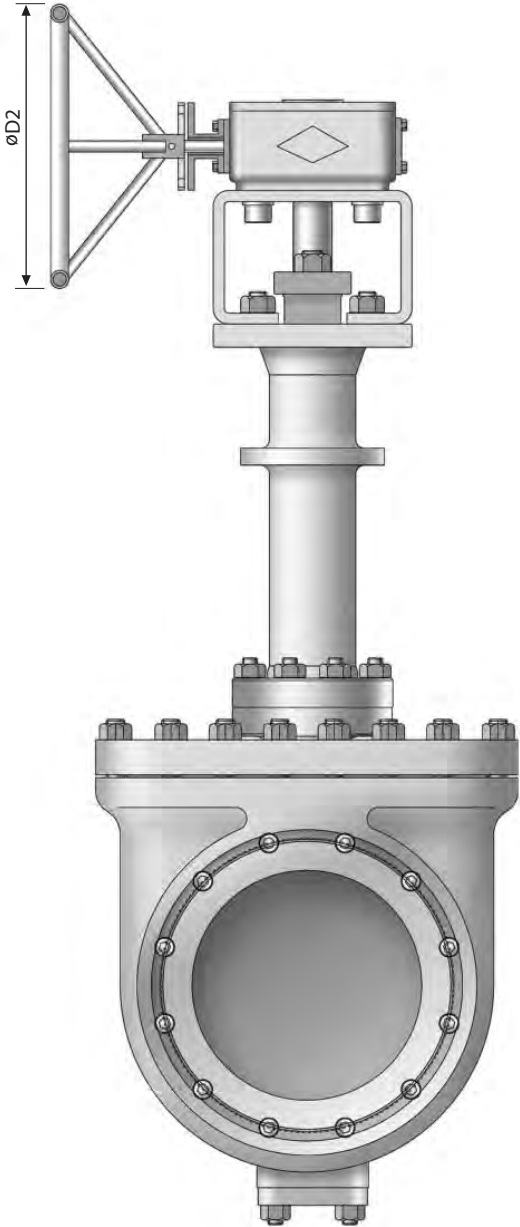
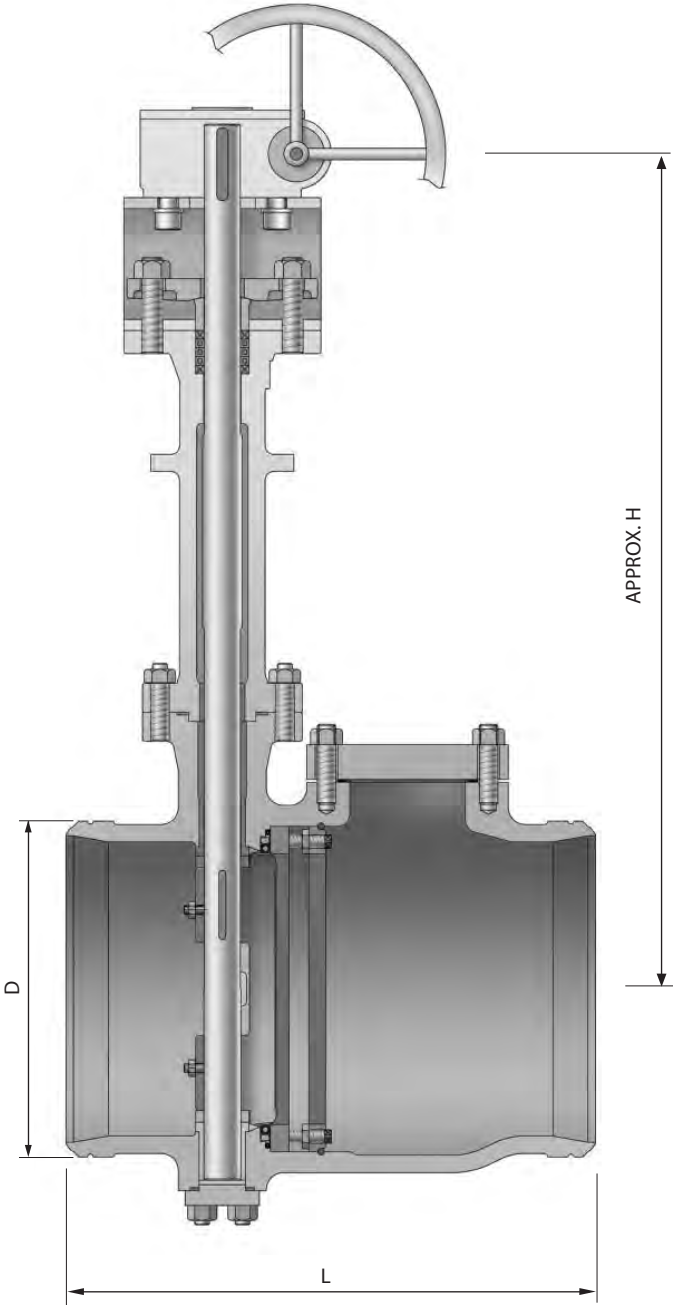

STANDARD MATERIAL SPECIFICATIONS

MATERIAL ACCORDING TO ASTM		
NO.	PART NAME	MATERIAL
1	BODY	A351 - CF3
2	DISC	A351 - CF8M+STL
3	STEM	A479 - 316
4	COVER	A351 - CF3
5	PACKING	GRAPHITE + CARBON FIBER
6	PACKING GLAND	A479 - 304
7	GLAND FLANGE	A351 - CF8
8	GLAND BOLT	A193 - B8
9	GLAND NUT	A194 - 8
10	BUSH BEARING	BI-MESH
11	KEY	A320 - B8
12	SEAL RING	304L SS+Cu ALLOY
13	STOP BOLT/NUT	A320 - B8/A194 - 8
14	YOKE	A240 - 304
15	YOKE BOLT	A193 - B8
16	YOKE NUT	A194 - 8
17	MOUNTING BOLT	A193 - B7+Cr
18	SPRING WASHER	A240 - 304
19	KEY	A576 - 1045
20	GEAR BOX	DUCTILE
21	CAP	A240 - 316
22	GASKET(CAP)	316SS+GRAPHITE
23	THRUST WASHER	B150 - C63000
24	SEAT RETAINER	A240 - 316
25	RETAINER BOLT	A320 - B8
26	RETAINER NUT	A194 - 8
27	ARRANGEMENT RING	A240-316
28	HANDWHEEL	A53 or STEEL
29	CAP BOLT	A320-B8M CLASS2
30	CAP NUT	A194-8MA
31	BONNET	A351 - CF3
32	BONNET BOLT	A320-B8M CLASS 2
33	BONNET NUT	A194-8MA
34	BONNET GASKET	316SS+GRAPHITE
35	COVER BOLT	A320-B8M CLASS 2
36	COVER NUT	A194-BMA
37	COVER GASKET	316SS+GRAPHITE
38	ADAPTER	316 SS
39	ADATER RETAINER	316 SS
40	LOCKING DEVICE	STEEL+ BRASS

DIMENSION AND WEIGHT

SIZE	6	8	10	12	14
d	153	204	254	305	337
L	403.4	419.1	457.2	501.7	571.5
SCH	10S	10S	10S	10S	10S
H	692	810	845	910	940
D2	300	300	400	400	500
Weight(Kg)	70	90	126	175	270

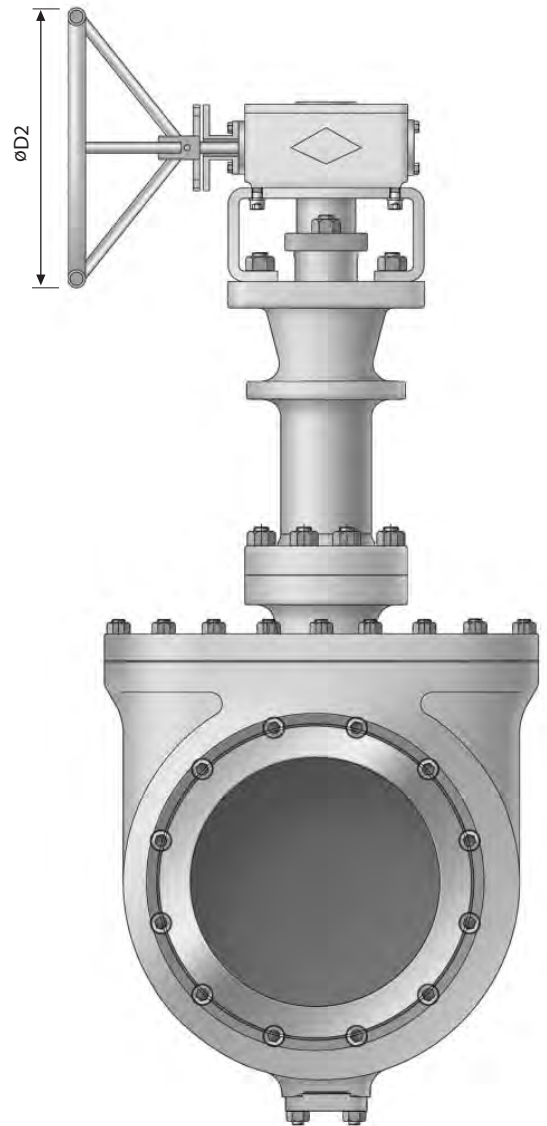
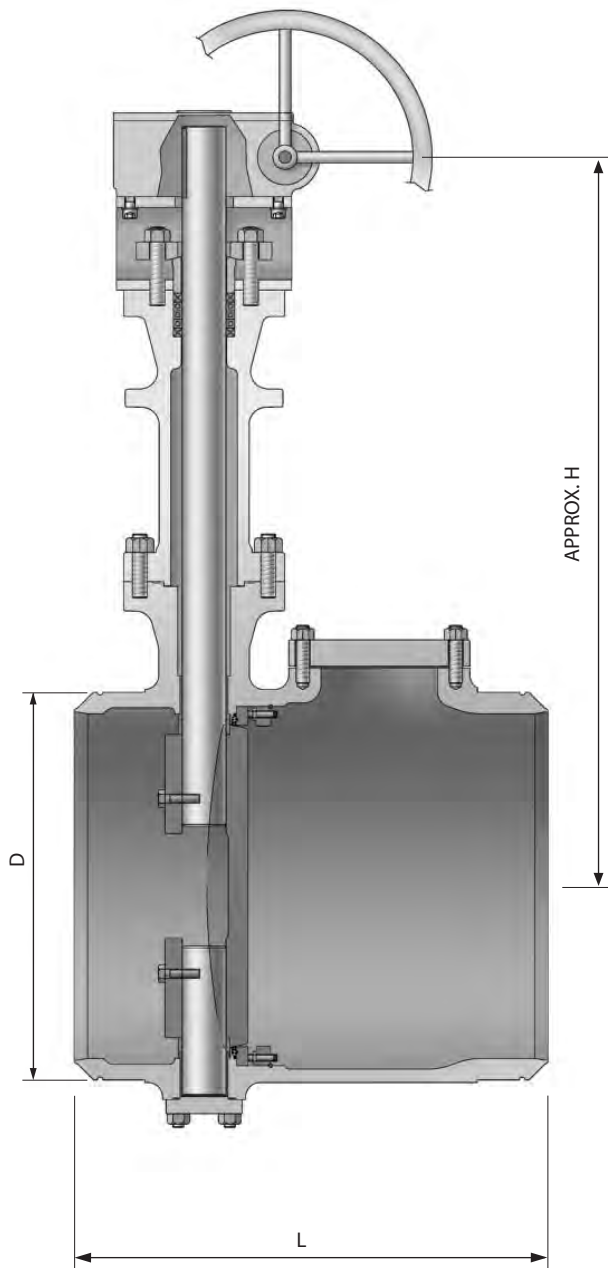

STANDARD MATERIAL SPECIFICATIONS

MATERIAL ACCORDING TO ASTM		
NO.	PART NAME	MATERIAL
1	BODY	A351 - CF3
2	DISC	A351 - CF8M+STL
3	STEM	A479 - 316
4	LOW STEM	A479 - 316
5	BUSH BEARING	BI-MESH
6	THRUST WASHER	B584 - C86300
9	STOP BOLT	A320 - B8
10	CAP	A240 - 316
11	CAP GASKET	316SS+GRAPHITE
12	CAP BOLT	A320-B8M CLASS 2
13	CAP NUT	A194 - 8MA
14	BONNET	A351 - CF3
15	BONNET GASKET	316SS+GRAPHITE
16	BONNET BOLT	A320-B8M CLASS 2
17	BONNET NUT	A194 - 8MA
18	PACKING	GRAPHITE + CARBON FIBER
19	PACKING GLAND	A479 - 304
20	GLAND FLANGE	A351 - CF8
21	GLAND BOLT	A193 - B8
22	GLAND NUT	A194 - 8
23	YOKE	A240 - 304
24	YOKE BOLT	A193 - B8
25	YOKE NUT	A194 - 8
26	KEY	A576 - 1045
27	GEAR BOX	DUCTILE
28	MOUNTING BOLT	A193 - B7+Cr
29	SPRING WASHER	A240 - 304
30	HANDWHEEL	A53 or STEEL
31	SEAL RING	304L SS+Cu ALLOY
32	ARRANGEMENT RING	A240 - 316
33	SEAT RETAINER	A240 - 316
34	RETAINER BOLT	A320 - B8
35	RETAINER NUT	A194 - 8
36	ADAPTER	316 SS
37	ADAPTER RETAINER	316 SS
38	COVER	A351 - CF3
39	COVER GASKET	316SS+GRAPHITE
40	COVER BOLT	A320-B8M CLASS 2
41	COVER NUT	A194 - 8MA
42	LOCKING DEVICE	STEEL+ BRASS

DIMENSION AND WEIGHT

SIZE	16	20	24	30	32	36
d	388	490	591	737	788	893
L	609.6	711.2	812.8	914.4	965.2	1016.0
SCH	10S	10S	10S	10	10	10
H	970	1110	1260	1375	1415	1465
D2	500	560	630	700	700	700
Weight(Kg)	330	600	1050	1750	2050	2800

MEMO

Fully Integrated, Yet Flexible
PKvalve

BELLOWS SEAL VALVES

- GATE VALVES***
- GLOBE VALVES***



BELLOWS SEAL VALVES

OPERATIONAL SERVICE FEATURES

In a maintenance aspect, it is true that this type of valve is accounted less than any other type, but the valve have some important advantages as follows:

1. Useful life is ensured.
2. There is a grease nipple on all bellows seal gate valves under current production to ensure correct lubrication over yoke bush.

The threads on stem in every kind of bellows seal valves should be kept clean if possible and lubricated periodically with high temperature grease.

It is recommended the preventive maintenance should be carried out at least every three months.

The maintenance has a particular importance when the valve is employed to high temperature application in case it is essential to use a grease of high temperature type.

At this time, it is desirable that the valve is operated from open to shut, and vice versa.

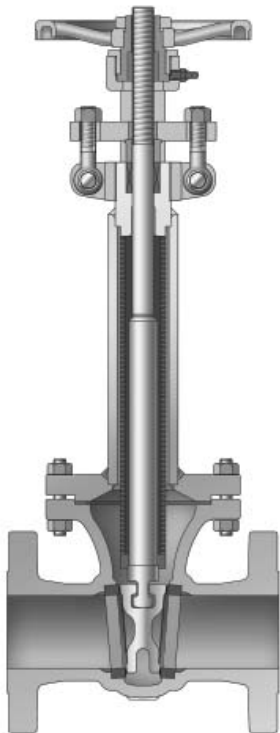

VALVE SELECTION

As a general guide to valve selection suitable for a specific application, the gate valve should be used mainly for low or medium pressure steam, steam tracing lines, or other services such as heat transfer.

The globe valve should be selected for medium or high pressure steam, where the isolation of vessels may be involved in safety problem. It is also used for toxic or explosive media handling and in every case that a trouble may occur in flow regulation.

It should be noted that we have a specially designed valve of which dry escape to gas or fluid is completely prevented. In the valve, conventional stem packing is replaced with flexible metallic membrane where all possible leaking paths through stem or body/bonnet joint are welded.

The bellows units applied to this valve were tested for life cycle to destruction, resulting in satisfactory test results meeting the life time, temperature, and pressure requirements of ASME B16.34.

LOW FUGITIVE EMISSION VALVE

Low Fugitive emission Valve (LFV) is designed and manufactured to ensure leakage of less than 100 ppm of volatile organic compounds. PK Valve has established the test facilities and made its own procedures with Emission Defence Packing (EDP) for fugitive emission test. By using the test facilities and procedures, room temperature cycle and thermal cycle testing have been performed, establishing critical design parameters necessary to achieve low fugitive emissions.

PRODUCTION MATERIALS

- Bellows Set : 321SS(Bellows) + 316SS(Holder)
- Carbon Steel : ASTM A216-WCB or Equivalent
- Stainless Steel : ASTM A351-CF8, CF8M, CF3, CF3M or Equivalent
- ASME SA designation material(e.g. ASME SA351-CF8M)

UNIT : NPS

TYPE \ CLASS	150	300	600
GATE	2-24	2-24	2-12
GLOBE	1/2-24	1/2-24	2-12

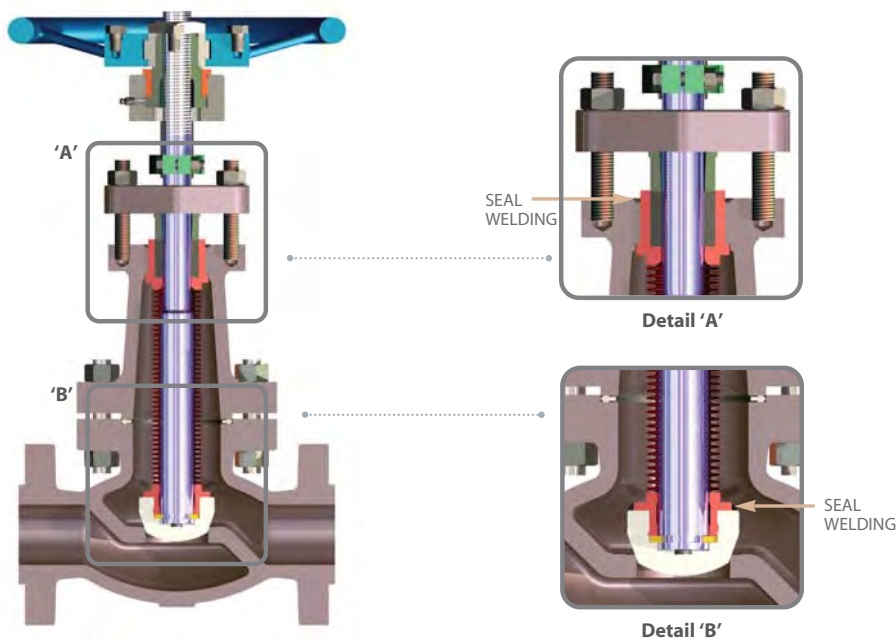

GATE VALVES

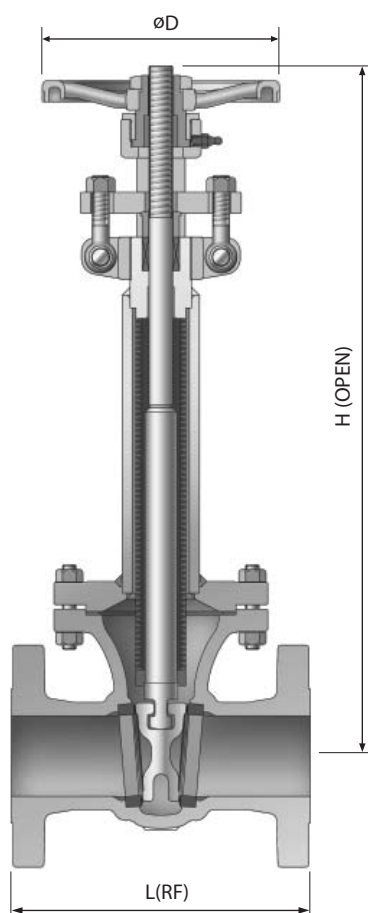

APPLICABLE STANDARD SPECIFICATION :

- BELLOWS INSPECTION AND TEST : MSS-SP-117
- END FLANGE : ASME B16.10
- BUTT WELDING ENDS : ASME B16.25
- SHELL WALL THICKNESS : ASME B16.34 OR API 600
- FACE TO FACE : ASME B 16.10

DIMENSION AND WEIGHT

CLASS 150

UNIT : mm

SIZE	2	3	4	5	6	8
L	177.8	203.2	228.6	254.0	266.7	292.1
D	200	224	355	315	355	400
H	639	890	1272	1141	1209	1588

CLASS 300

UNIT : mm

SIZE	2	3	4	5	6	8
L	215.9	282.4	304.8	381.0	403.4	419.1
D	200	224	355	315	355	400
H	639	890	1272	1141	1209	1588

CLASS 600

UNIT : mm

SIZE	3	4
L	355.6	431.8
D	250	355
H	974	1272

STANDARD MATERIAL SPECIFICATIONS

NO.	PART NAME	MATERIAL
1	BODY	A216 - WCB
2	YOKE	A216 - WCB
3	WEDGE	A217 - CA15+STL
4	STEM	A479 - 410
5	HAND WHEEL	A197
6	BODY SEAT RING	A576 - 1020+STL(S20C)
7	BELLOWS	STAINLESS STEEL TYPE321+316
8	GASKET	SPIRAL WOUND / GRAPHITE+304+304
9	PACKING	GRAPHITE+GRAPHITE WITH INCONEL WIRE
10	GLAND FLANGE	A283 - D
11	HINGE BOLT	A307 - B
12	HINGE NUT	A194 - 2H
13	HINGE PIN	A576 - 1020
14	PACKING GLAND	A576 - 1020+Cr
15	BONNET BOLT	A193 - B7
16	BONNET NUT	A194 - 2H
17	YOKE CAP	A576 - 1020
18	YOKE SLEEVE	A439 - D2C
19	HANDLE NUT	A47 - 32510+Zn
20	SET SCREW	STEEL
21	NIPPLE	STEEL+Cr
22	FLANGE	A216 - WCB
23	EXTENSION PIPE	A106 - B

GLOBE VALVES

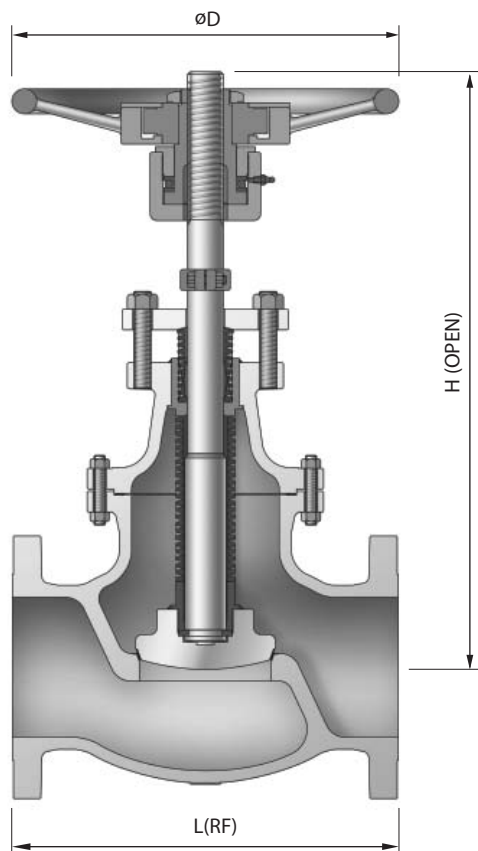

APPLICABLE STANDARD SPECIFICATION :

- BELLOWS INSPECTION AND TEST : MSS-SP-117
- END FLANGE : ASME B16.10
- BUTT WELDING ENDS : ASME B16.25
- SHELL WALL THICKNESS : ASME B16.34 OR API 600
- FACE TO FACE : ASME B 16.10

DIMENSION AND WEIGHT

CLASS 150

UNIT : mm

SIZE	2	2½	3	4	5	6	8	10
L	203.2	215.9	241.3	292.1	355.6	406.4	495.3	622.3
D	200	200	224	355	400	450	560	560
H	413	378	432	579	670	773	945	1208

CLASS 300

UNIT : mm

SIZE	2	2½	3	4	5	6	8	10
L	266.7	292.1	317.5	355.6	400.1	444.5	558.8	622.3
D	200	200	224	355	400	450	560	560
H	364	378	432	569	670	773	945	1213

CLASS 600

UNIT : mm

SIZE	2½	3
L	330.2	355.6
D	355	355
H	576	583

STANDARD MATERIAL SPECIFICATIONS

NO.	PART NAME	MATERIAL
1	BODY	A216 - WCB
2	BONNET	A216 - WCB
3	DISC	A216 - WCB+STL
4	STEM	A479 - 410
5	HAND WHEEL	A216 - WCB
6	BODY SEAT	A216 - WCB+STL
7	BELLOWS SET	STAINLESS STEEL TYPE321+316
8	GASKET	SPIRAL WOUND / GRAPHITE+304+304
9	PACKING	GRAPHITE+GRAPHITE WITH INCONEL WIRE
10	GLAND FLANGE	A105
11	HINGE BOLT	A307 - B
12	HINGE NUT	A194 - 2H
13	PACKING GLAND	A576 - 1020+Cr
14	BONNET BOLT	A193 - B7
15	BONNET NUT	A194 - 2H
16	YOKE	A283 - D
17	YOKE SLEEVE	A439 - D2C
18	YOKE CAP	A576 - 1020
19	STOPPER	A216 - WCB
20	BOLT	A307 - B
21	NUT	A563 - A
22	HAND WHEEL NUT	A47 - 32510+Zn

MEMO

Fully Integrated, Yet Flexible
PKvalve

BUTTERFLY VALVES

- *TRIPLE OFFSET TYPE*
- *DOUBLE ECCENTRIC TYPE*
- *CONCENTRIC TYPE*



TRIPLE OFFSET TYPE

TRIPLE OFFSET DESIGN PRINCIPLES

Triple offset metal seat butterfly valves provide a bi-directional and bubble-tight shutoff which is attributed to the geometry of triple offset seat.

The valve stem is offset by seat (1st offset) and the valve seat surface center line is offset against the center line of pipe (2nd offset) and the conical axis is offset by valve center line (3rd offset: inclined cone). The 3rd offset completely eliminates rubbing.

The seat surfaces of body and seal ring in triple offset valve contact with the inclined “cone-in-cone” and this design requires excellent sealing and seat part durability by slight wedging effect.

In addition, the angle of contact between body and seal ring has a good sealing performance by low torque because the angle travels the initial torque from actuator to seat parts without any loss by jamming.

This valve is characteristic of concentric, offset and double offset construction with remarkable sealing performance and seat part durability, and moreover it is hardly needed to repair.

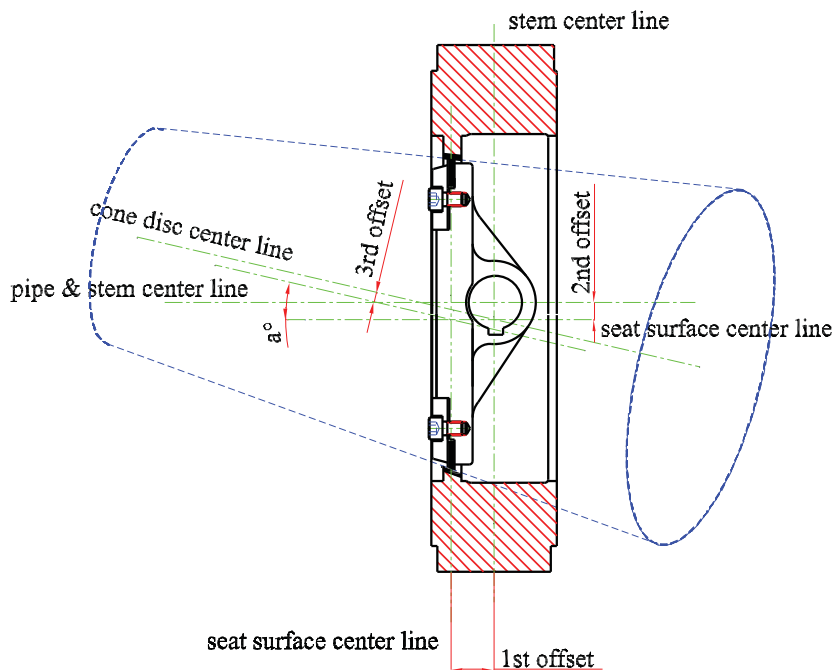

CHARACTERISTICS AND MERITS

- Excellent durability of seat part and low operating torque by non-rubbing characteristics with triple offset construction.
- Bi-directional zero leakage service by resilient metal sealing and torque seating.
- Unrestricted selection of face to face dimensions for API, ASME(ANSI), BS, ISO, etc. and perfect interchangeability of gate, ball, plug, high performance butterfly, and other valves.
- Low emission by quarter turn construction and good performance at automation by virtue of low operating torque and low cost.

DESIGN FEATURE

- Designed in accordance with ASME B 16.34 or other customer requirements.
- Fire safe design

STANDARD

OPTION

FACE TO FACE DIMENSIONS

WAFER AND LUG TYPE

- | | |
|---|--|
| <ul style="list-style-type: none">• API 609 Table 2./ MSS-SP-68 Table 1
Class 150 & 300 : 3"~ 24"
Class 600 : 3"~ 12" | <ul style="list-style-type: none">• ISO 5752 Table 5
Class 150 & 300 : 28"~ 48"
Class 600 : 14"~ 24" |
|---|--|

DOUBLE FLANGE

- | | |
|---|--|
| <ul style="list-style-type: none">• ISO 5752 Table 4, BS 5155 Table 6 (short)
Class 150 & 300 : 3"~ 24"
ISO 5752 Table 4, BS 5155 Table 6 (long)
Class 600 : 3"~12" | <ul style="list-style-type: none">• ISO 5752 Table 4, BS 5155 Table 6 (short)
Class 150 & 300 : 28"~ 80"
ISO 5752 Table 4, BS 5155 Table 6 (long)
Class 150 & 300 : 3"~ 80"
Class 600 : 14"~24"• ASME B16.10
Class 150 & 300 : 3"~ 24"
Class 600 : 3"~24" |
|---|--|

BUTT WELDING

- ISO 5752 Table 4, BS 5155 Table 6(long)
Class 150 & 300 : 3"~ 80"
Class 600 : 3"~24"

END FLANGE

- | | |
|---|--|
| <ul style="list-style-type: none">• ASME B16.5 : Class 150, 300,600
JIS B2210 : 10K, 16K, 20K, 30K, 40K
DIN, ISO PN10, PN16, PN20, PN25, PN40 | <ul style="list-style-type: none">• ASME B16.47 series A : Class 150, 300
MSS-SP-44 : Class 150, 300, 600
BS 3293 : Class 150, 300 |
|---|--|

OPERATING

- | | |
|--|---|
| <ul style="list-style-type: none">• MAUNAL WORM GEAR | <ul style="list-style-type: none">• ELECTRIC, PNEUMATIC & HYDRAULIC
ACTUATOR LOCK LEVER |
|--|---|

MOUNTING FLANGE

- ISO 5211

TESTING

- | | |
|---|---|
| <ul style="list-style-type: none">• API 598 | <ul style="list-style-type: none">• MSS-SP-61, ANSI B16.104 |
|---|---|

BODY

- The valve body shall be one piece cast or fabrication.
- The body can be supplied with different types of materials in wafer, lug, or flanged and butt welding end connections to satisfy all installation requirements.

BODY SEAT

- The valve seat shall be integrated with the body.
- Stellite or stainless steel shall be applied on the seating surface of valve body.
- The valve seat is designed for inclined cone to ensure non-rubbing, non-jamming, bi-directional shutoff, and zero leakage.

DISC

- The valve disc shall be the same material as the valve body. It is supported by laminated seal ring, which is kept in place by seat retainer ring bolted to the disc and can be replaced easily.
- The spiral wound gasket shall be provided between laminated seal ring and disc.

SEAL RING (LAMINATED)

- The seal ring shall be resilient stainless steel lamella alternated by graphite, aramid fiber & ceramic fiber layers.
- The surface contacting between seal ring and body seat is an inclined cone type and the inclined angle generates a slight wedging effect.
- With a seat retainer ring bolted to the disc, the seal ring is fixed to disc not too tightly to be replaced easily.

STEM

- The stem shall be stainless steel and one piece & two piece construction.
- The stem shall be fixed to the disc by pin or in combination of pin and key. It can be protected by internal thrust bush and bush bearing.
- The thrust bush and bush bearing shall be provided to locate the valve disc in a proper position.
- The retainer ring shall be installed to avoid blowing out the stem.

PACKING

- The packing shall be consist of two braided rings in the top and bottom of valve and three die formed graphite rings in the middle.
- The lantern ring may be provided as required by customer.

ACTUATORS

- All valves shall be self-locking manual gear operation type which is served as standard.
- Electric, pneumatic or hydraulic actuator may be provided as required by customer.

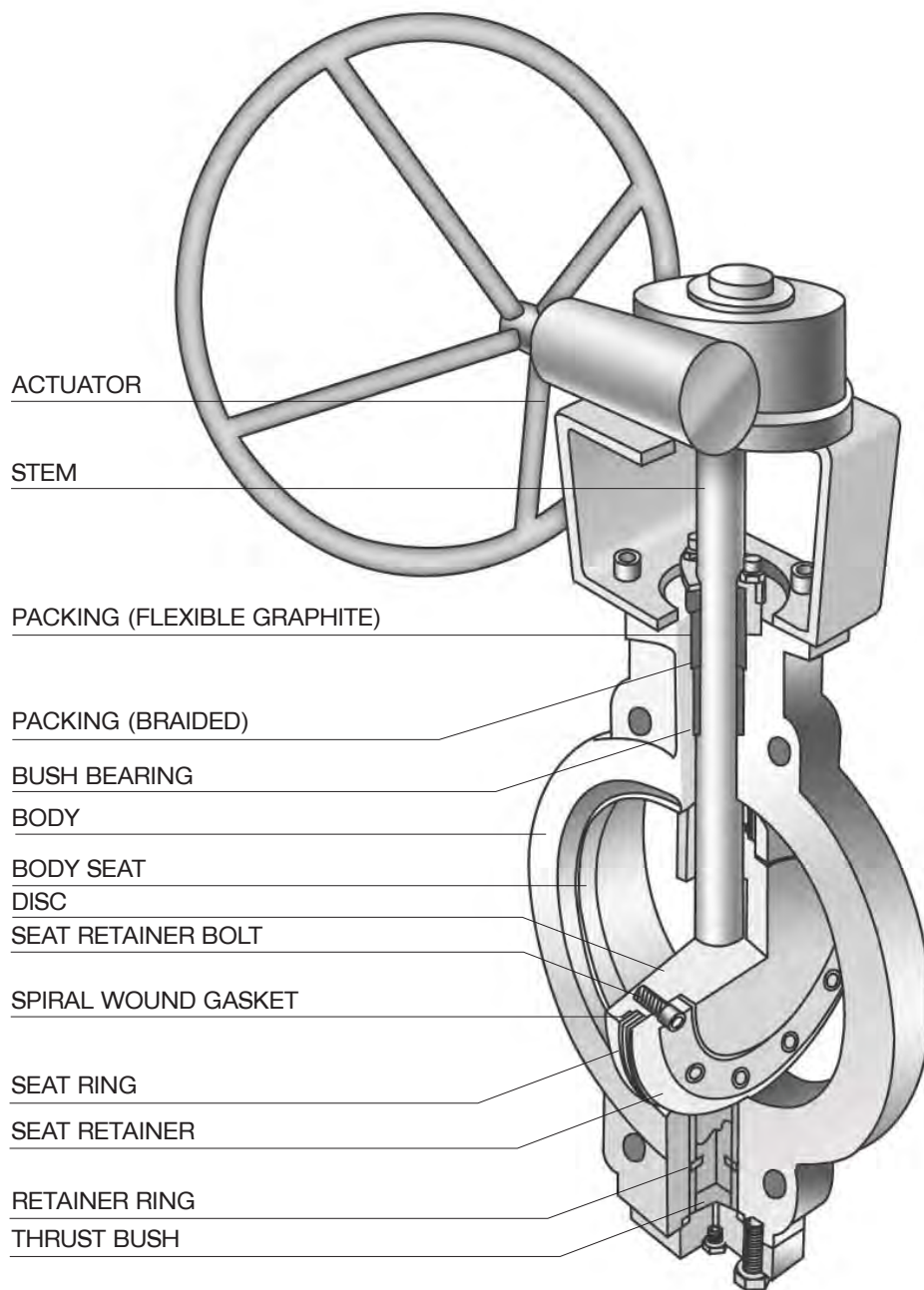

SEAT RING
316SS+Graphite Laminated

SPIRAL WOUND GASKET
316SS+Graphite

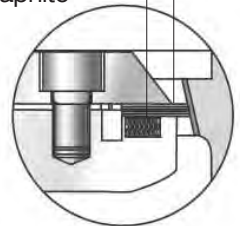

SEAT RING (Solid metal)
316SS+Nitr

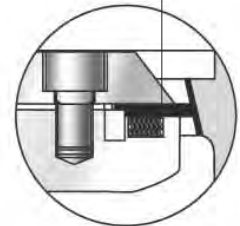

STANDARD MATERIAL LIST

MATERIAL ACCORDING TO ASTM

	NO.	PART NAME	MATERIAL		
S T A N D A R D	1	BODY	A216 - WCB	A217 - WC9	A351 - CF8M
	2	SEAT SURFACE	STELLITE.6 Faced	STELLITE NO.6 Faced	STELLITE.6 Faced
	3	DISC	A217 - CA15	A217 - CA15	A351 - CF8M
	4	STEM	A479 - 410	A479 - 410	A564 - 630
	5	RETAINER RING	A479 - 410	A479 - 410	A479 - 316+Hcr
	6	PACKING	Graphite	Graphite	Graphite
	7	PACKING GLAND	A576 - 1020 + Cr	A479 - 410	A479 - 316
	8	GLAND FLANG	A105 or A576 - 1020(S20C)	A105 or A576 - 1020(S20C)	A351 - CF8
	9	GLAND BOLT	A193 - B7	A193 - B7	A193 - B8
	10	GLAND NUT	A194 - 2H	A194 - 2H	A194 - 8
	11	BUSH BEARING	A479 - 304 + Nitr.	A479 - 304 + Nitr.	A479 - 316 + Hcr. Plating
	12	KEY	A479 - 410	A479 - 410	A564 - 630
	13	SEAL RING	316 SS + GRAPHITE	316 SS + GRAPHITE	316 SS + GRAPHITE
	14	TAPER PIN	410 SS	410 SS	A564 - 630
	15	YOKE	A576 - 1020(S20C)	A576 - 1020(S20C)	A576 - 1020 + Zn. Plating
	16	YOKE BOLT	A193 - B7	A193 - B7	A193 - B8
	17	YOKE NUT	A194 - 2H	A194 - 2H	A194 - 8
	18	MOUNTING BOLT	A193 - B7 or EQ.	A193 - B7 or EQ.	A193 - B7+Hcr or EQ.
	19	SPRING WASHER	STEEL	STEEL	304 SS
	20	KEY	A576 - 1045	A576 - 1045	A576 - 1045
	21	GEAR BOX	DUCTILE	DUCTILE	DUCTILE
	22	CAP	A576 - 1020(S20C)	A240 - 304	A240 - 316
	23	GASKET(CAP)	304 SS + GRAPHITE	304 SS + GRAPHITE	316 SS + GRAPHITE
	24	THRUST BUSH	A479 - 410	A479 - 410	A479 - 316
	25	SEAT RETAINER	304SS	304SS	A240 - 316
	26	RETAINER BOLT	A193 - B8	A193 - B8	A193 - B8M
	27	BUSH BEARING	A479 - 304 + Nitr	A479 - 304 + Nitr	A479 - 316 + Hcr. Plating
	28	GASKET	304 SS + GRAPHITE	304 SS + GRAPHITE	316 SS + GRAPHITE
	29	HANDWHEEL	A53	A53	A53
	30	CAP BOLT	A193 - B7	A193 - B16	A193 - B8
	31	CAP NUT	A194 - 2H	A194 - 4	A194 - 8
	32	SEAL RING PIN	A479 - 304	A479 - 304	A479 - 316
	33	SPACER	A479 - 304	A479 - 304	A479 - 316
O P T I O N	2	SEAT SURFACE	STELLITE NO.6 Faced Duplex SS + GRAPHITE	STELLITE NO.6 Faced Duplex SS + GRAPHITE	STELLITE NO.6 Faced Duplex SS + GRAPHITE
	13	SEAL RING	316 SS + ARAMID 316 SS + CERAMIC A564 - 630 or 316SS + Nitr.	316 SS + ARAMID 316 SS + CERAMIC A564 - 630 or 316SS + Nitr.	316 SS + ARAMID 316 SS + CERAMIC A564 - 630 or 316 S + Nitr.
	34	LANTERN RING	304SS	410 SS	316 SS
	35	PLUG	A105	410 SS	316 SS
	40	GREASE FITTING	CARBON STEEL + Cr. Plating	316 SS	316 SS
		DRAIN PLUG	A105	410 SS	316 SS

• NOTE

1. Nitr : Hardened by Nitriding, HCr : Hard Cr. Plating, ENP. : Electroless Nickel Plating
2. CLASS 150 & 300 : 316 SS Faced & Integral
CLASS 600 & OVER : STELLITE NO.6 Faced
3. RECOMMEND SPARE PARTS : PART NO.6, 13, 23, 28

TOB VALVES-WAFER TYPE-OUTDRAWING

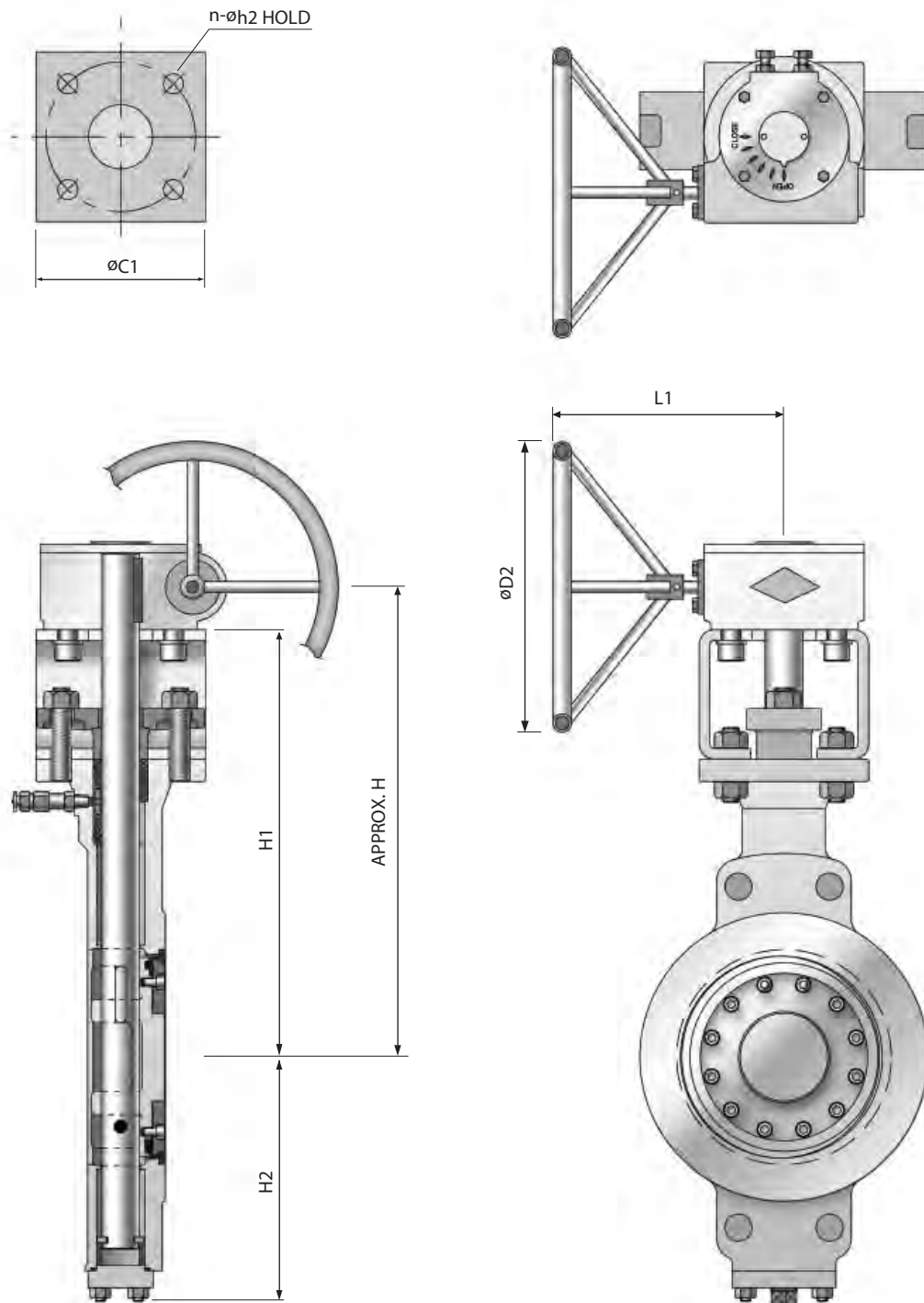

TOB VALVES - WAFER TYPE

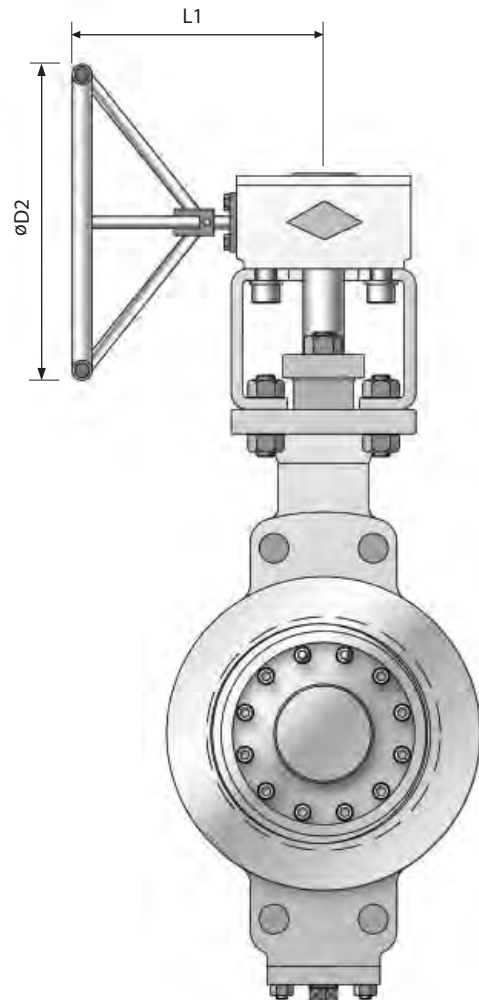
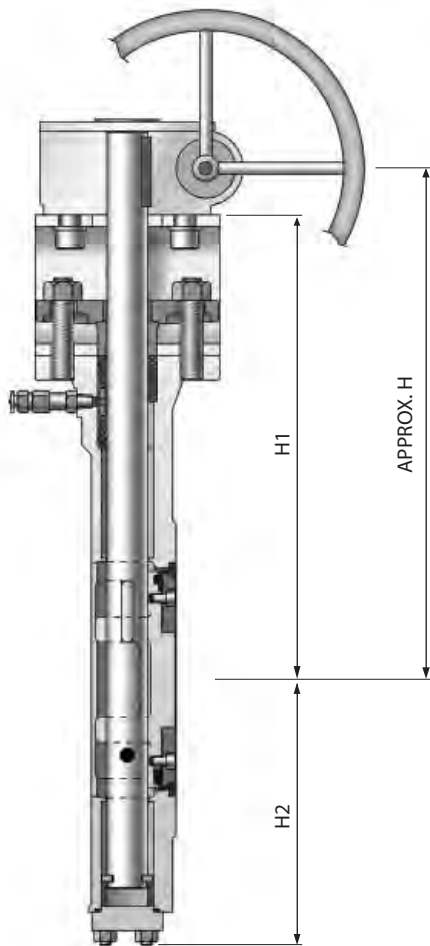
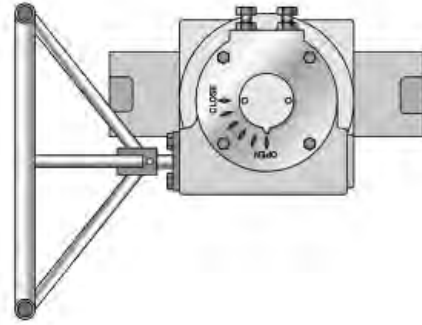
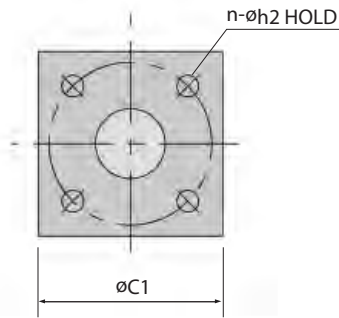

TOB VALVES - WATER TYPE - DIMENSIONS

UNIT : mm

CLASS 150

SIZE		L	FLANGE DIMENSION									MOUNTING BASE				Weight (Kgf)
Inch	mm		C	h	a	h1	H	H1	H2	D2	L1	TYPE	C1	n	h2	
3	80	48	152.4	-	-	19.1	252	228	142	200	165	F07	70	4	9	21
4	100	54	190.5	-	-	19.1	274	250	162	200	165	F07	70	4	9	27
5	125	57	215.9	-	-	22.2	290	266	170	200	165	F07	70	4	9	32
6	150	57	241.3	-	-	22.2	320	296	179	200	165	F07	70	4	9	35
8	200	64	298.4	-	-	22.2	384	344	210	300	270	F10	102	4	11	53
10	250	71	361.9	-	-	25.4	434	394	243	300	270	F10	102	4	11	74
12	300	81	431.8	-	-	25.4	520	470	287	400	335	F14	140	4	18	95
14	350	92	476.3	-	-	28.6	544	494	316	400	335	F14	140	4	18	131
16	400	102	539.7	-	-	28.6	646	578	349	500	375	F16	165	4	22	165
18	450	114	577.8	-	-	31.8	663	595	381	500	375	F16	165	4	22	230
20	500	127	635.0	1 1/8-8	28.6	-	698	630	412	500	375	F16	165	4	22	280
24	600	154	749.3	1 1/4-8	31.8	-	813	743	475	600	485	F25	254	8	18	450

CLASS 300

SIZE		L	FLANGE DIMENSION									MOUNTING BASE				Weight (Kgf)
Inch	mm		C	h	a	h1	H	H1	H2	D2	L1	TYPE	C1	n	h2	
3	80	48	168.2	-	-	22.2	252	228	142	200	165	F07	70	4	9	21
4	100	54	200.0	-	-	22.2	274	250	162	200	165	F07	70	4	9	27
5	125	59	234.9	-	-	22.2	310	295	170	300	270	F10	102	4	11	38
6	150	59	269.8	-	-	22.2	375	336	199	300	270	F10	102	4	11	45
8	200	73	330.2	-	-	25.4	450	400	227	400	335	F14	140	4	18	72
10	250	83	387.3	1-8	25.4	-	499	449	265	400	335	F14	140	4	18	135
12	300	92	450.8	1 1/8-8	28.6	-	562	497	302	500	375	F16	165	4	22	148
14	350	117	514.3	1 1/8-8	28.6	-	616	551	328	500	375	F16	165	4	22	208
16	400	133	571.5	1 1/4-8	31.8	-	676	606	367	600	485	F25	254	8	18	298
18	450	149	628.6	1 1/4-8	31.8	-	711	641	402	600	485	F25	254	8	18	382
20	500	159	685.8	1 1/4-8	31.8	-	796	721	432	700	520	F30	298	8	22	450
24	600	181	812.8	1 1/2-8	38.1	-	914	837	530	700	515	F30	298	8	22	680

CLASS 600

SIZE		L	FLANGE DIMENSION									MOUNTING BASE				Weight (Kgf)
Inch	mm		C	h	a	h1	H	H1	H2	D2	L1	TYPE	C1	n	h2	
3	80	54	168.2	-	-	22.2	289	249	148	200	270	F07	70	4	9	29
4	100	64	215.9	-	-	25.4	370	320	180	300	335	F10	102	4	11	38
5	125	78	266.7	-	-	28.6	405	355	195	400	335	F14	140	4	18	55
6	150	78	292.1	1-8	25.4	-	420	370	225	400	335	F14	140	4	18	75
8	200	102	349.2	1 1/8-8	28.6	-	490	425	225	500	375	F16	165	4	22	136
10	250	117	431.8	1 1/4-8	31.8	-	545	480	310	500	375	F16	165	4	22	200
12	300	140	488.9	1 1/4-8	31.8	-	630	560	330	600	485	F25	254	8	18	295

※ NOT SPECIFIED CLASS AND SIZE, PLEASE CONTACT TO SALES DEPARTMENT

• NOTE

1. VALVE DESIGN : ASME B16.34
2. FACE TO FACE DIMENSION : API 609 (WAFFER TYPE)
3. END FLANGE DIMENSION : ASME B16.5

TOB VALVES-LUG TYPE

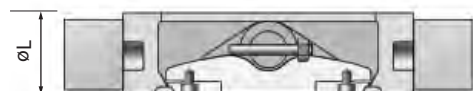
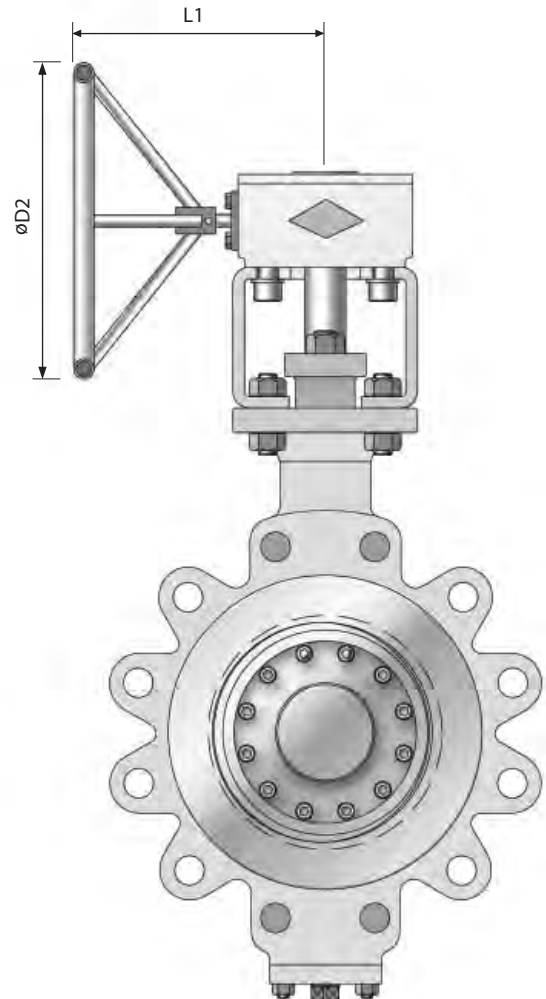
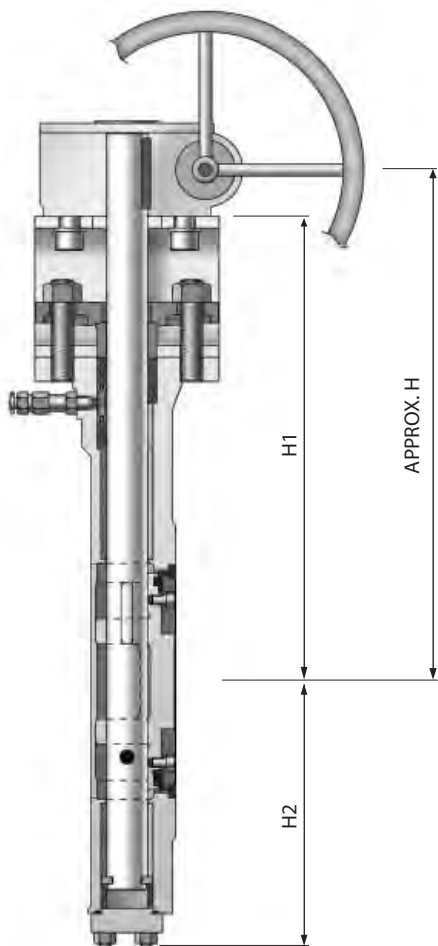
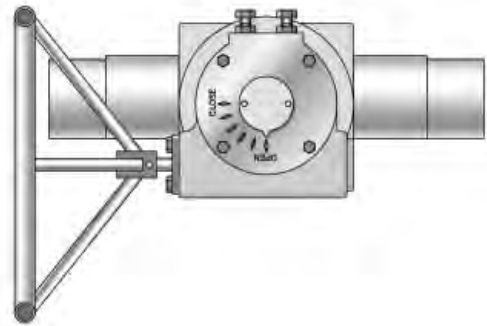
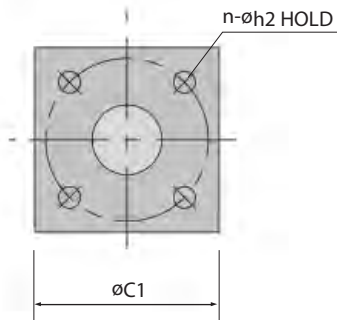

TOB VALVES - LUG TYPE - DIMENSIONS

UNIT : mm

CLASS 150

SIZE		L	FLANGE DIMENSION									MOUNTING BASE				Weight (Kgf)
Inch	mm		C	h	a	n1	H	H1	H2	D2	L1	TYPE	C1	n	h2	
3	80	48	152.4	5/8-11	15.8	4	252	228	142	200	165	F07	70	4	9	23
4	100	54	190.5	5/8-11	15.8	8	274	250	162	200	165	F07	70	4	9	30
5	125	57	215.9	3/4-10	19.1	8	290	266	170	200	165	F07	70	4	9	36
6	150	57	241.3	3/4-10	19.1	8	320	316	179	200	165	F07	70	4	9	39
8	200	64	298.4	3/4-10	19.1	8	384	344	208	300	270	F10	102	4	11	59
10	250	71	361.9	7/8-9	22.2	12	434	394	241	300	270	F10	102	4	11	83
12	300	81	431.8	7/8-9	22.2	12	520	470	267	400	335	F14	140	4	18	110
14	350	92	476.3	1-8	25.4	12	544	494	316	400	335	F14	140	4	18	153
16	400	102	539.7	1-8	25.4	16	643	578	349	500	375	F16	165	4	22	193
18	450	114	577.8	1 1/8-8	28.6	16	660	595	381	500	375	F16	165	4	22	258
20	500	127	635.0	1 1/8-8	28.6	20	695	630	412	500	375	F16	165	4	22	318
24	600	154	749.3	1 1/4-8	31.8	20	813	743	475	600	485	F25	254	8	18	507

CLASS 300

SIZE		L	FLANGE DIMENSION									MOUNTING BASE				Weight (Kgf)
Inch	mm		C	h	a	n1	H	H1	H2	D2	L1	TYPE	C1	n	h2	
3	80	48	168.2	3/4-10	19.1	8	252	228	142	200	165	F07	70	4	9	24
4	100	54	200.0	3/4-10	19.1	8	274	250	162	200	165	F07	70	4	9	32
5	125	59	234.9	3/4-10	19.1	8	319	295	170	300	270	F10	102	4	11	44
6	150	59	269.8	3/4-10	19.1	12	375	336	199	300	270	F10	102	4	11	52
8	200	73	330.2	7/8-9	22.2	12	450	400	227	400	335	F14	140	4	18	83
10	250	83	287.3	1-8	25.4	16	499	449	265	400	335	F14	140	4	18	151
12	300	92	450.8	1 1/8-8	28.6	16	562	497	302	500	375	F16	165	4	22	172
14	350	117	514.3	1 1/8-8	28.6	20	616	551	328	500	375	F16	165	4	22	249
16	400	133	571.5	1 1/4-8	31.8	20	616	606	367	600	375	F25	254	8	18	352
18	450	149	628.6	1 1/4-8	31.8	24	711	641	402	600	485	F25	254	8	18	449
20	500	159	685.8	1 1/4-8	31.8	24	798	721	432	700	520	F30	298	8	22	534
24	600	181	812.8	1 1/2-8	38.1	24	914	837	530	700	515	F30	298	8	22	812

CLASS 600

SIZE		L	FLANGE DIMENSION									MOUNTING BASE				Weight (Kgf)
Inch	mm		C	h	a	n1	H	H1	H2	D2	L1	TYPE	C1	n	h2	
3	80	54	168.2	3/4-10	19.1	4	289	249	150	300	270	F10	102	4	11	32
4	100	64	215.9	7/8-9	22.2	4	370	320	181	400	335	F14	140	4	14	45
5	125	78	266.7	1-8	25.4	4	405	355	210	400	335	F14	140	4	18	67
6	150	78	292.1	1-8	25.4	8	420	370	223	400	335	F14	140	4	18	88
8	200	102	349.2	1 1/8-8	28.6	8	490	425	255	500	375	F16	165	4	22	157
10	250	117	431.8	1 1/4-8	31.8	12	545	475	309	600	485	F25	254	8	18	237
12	300	140	488.9	1 1/4-8	31.8	16	630	560	330	600	485	F25	254	8	18	343

※ NOT SPECIFIED CLASS AND SIZE, PLEASE CONTACT TO SALES DEPARTMENT

• NOTE

1. VALVE DESIGN : ASME B16.34
2. FACE TO FACE DIMENSION : API 609 (LUG TYPE)
3. END FLANGE DIMENSION : ASME B16.5

TOB VALVES - DOUBLE FLANGE TYPE

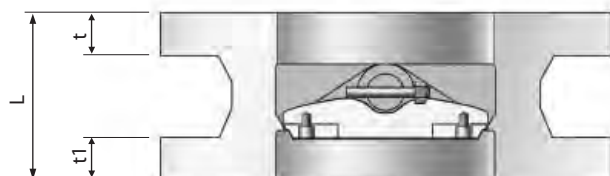
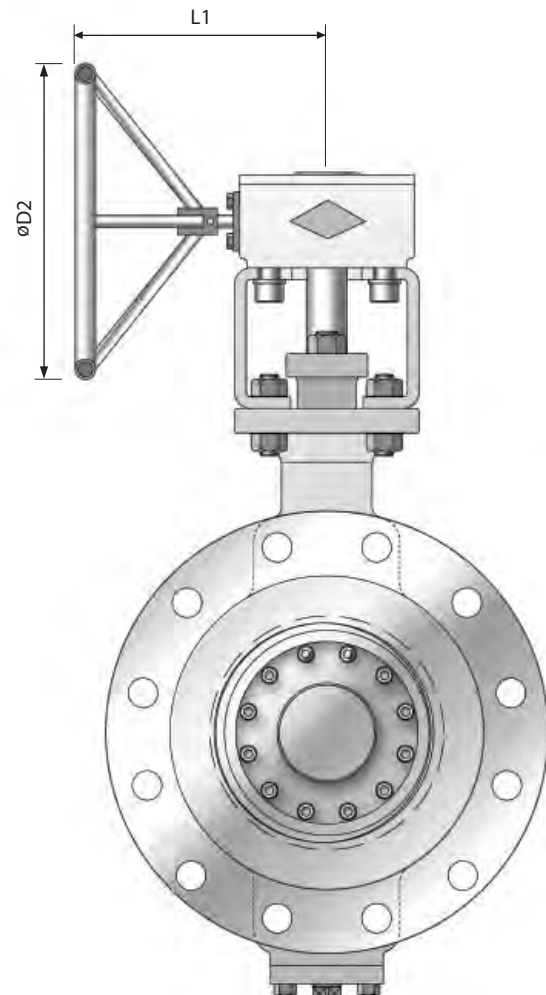
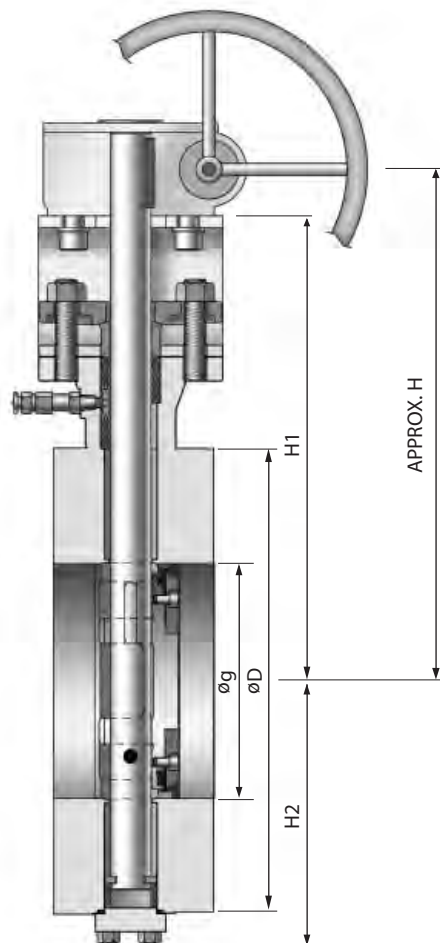
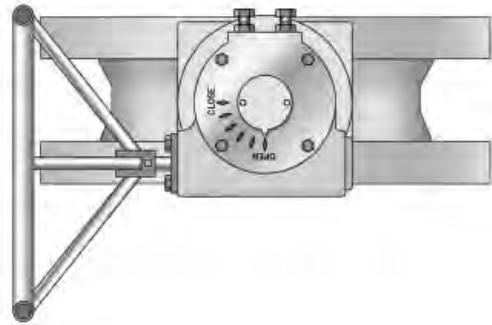
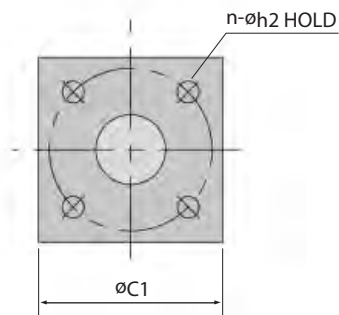

TOB VALVES - DOUBLE FLANGE(SHORT) TYPE - DIMENSIONS

UNIT : mm

CLASS 150

SIZE		L	FLANGE DIMENSION									MOUNTING BASE					Weight (Kgf)			
Inch	mm		D	g	C	t	h	a	n1	h1	H	H1	H2	D2	L1	TYPE		C1	n	h2
3	80	114	191	127.0	152.4	19.1	5/8-11	15.8	4	19.1	252	228	142	200	165	F07	70	4	9	27
4	100	127	229	157.2	190.5	24.0	5/8-11	15.8	8	19.1	274	250	162	200	165	F07	70	4	9	35
5	125	140	254	185.7	215.9	24.0	3/4-10	19.1	8	22.2	319	295	170	200	165	F07	70	4	9	41
6	150	140	279	215.9	241.3	25.4	3/4-10	19.1	8	22.2	340	316	179	200	165	F07	70	4	9	45
8	200	152	343	269.7	298.4	28.5	3/4-10	19.1	8	22.2	384	344	208	300	270	F10	102	4	11	68
10	250	165	406	323.9	361.9	30.3	7/8-9	22.2	12	25.4	434	394	241	300	270	F10	102	4	11	97
12	300	178	483	381.0	431.8	31.8	7/8-9	22.2	12	25.4	520	470	267	400	335	F14	140	4	18	133
14	350	190	533	412.8	476.3	35.1	1-8	25.4	12	28.6	544	494	316	400	335	F14	140	4	18	188
16	400	216	597	469.9	539.7	36.6	1-8	25.4	16	28.6	643	578	349	500	375	F16	140	4	22	238
18	450	222	635	533.4	577.8	39.7	1 1/8-8	28.6	16	31.8	660	595	381	500	375	F16	165	4	22	302
20	500	229	699	584.2	635.0	43.0	1 1/8-8	28.6	20	31.8	695	630	412	500	375	F16	165	4	22	380
24	600	267	813	692.2	749.3	47.8	1 1/4-8	31.8	20	35.1	813	743	473	600	485	F25	254	8	18	599

CLASS 300

SIZE		L	FLANGE DIMENSION									MOUNTING BASE					Weight (Kgf)			
Inch	mm		D	g	C	t	h	a	n1	h1	H	H1	H2	D2	L1	TYPE		C1	n	h2
3	80	114	210	127.0	168.2	28.5	3/4-10	19.1	8	22.2	252	228	142	200	165	F07	70	4	9	27
4	100	127	254	157.2	200.0	31.8	3/4-10	19.1	8	22.2	274	250	162	200	165	F07	70	4	9	35
5	125	140	279	185.7	234.9	35.0	3/4-10	19.1	8	22.2	319	295	170	300	270	F10	102	4	11	52
6	150	140	318	215.9	269.8	36.6	3/4-10	19.1	12	22.2	375	336	199	300	270	F10	102	4	11	63
8	200	152	381	269.7	330.2	41.2	7/8-9	22.2	12	25.4	450	400	227	400	335	F14	140	4	18	101
10	250	165	445	323.9	387.3	47.8	1-8	25.4	16	28.6	499	449	265	400	335	F14	140	4	18	176
12	300	178	521	381.0	450.8	50.8	1 1/8-8	28.6	16	31.8	562	497	302	500	375	F16	165	4	22	210
14	350	190	584	412.8	514.3	53.9	1 1/8-8	28.6	20	31.8	616	551	328	500	375	F16	165	4	22	315
16	400	216	648	469.9	571.5	57.2	1 1/4-8	31.8	20	35.1	616	606	367	600	485	F25	254	8	18	440
18	450	222	711	533.4	628.6	60.5	1 1/4-8	31.8	24	35.1	711	641	402	600	485	F25	254	8	18	558
20	500	229	775	584.2	685.8	63.5	1 1/4-8	31.8	24	35.1	798	721	432	700	520	F30	298	8	22	670
24	600	267	914	692.2	812.8	69.9	1 1/2-8	38.1	24	41.2	914	837	530	700	515	F30	298	8	22	1025

CLASS 600

SIZE		L	FLANGE DIMENSION									MOUNTING BASE					Weight (Kgf)			
Inch	mm		D	g	C	t	h	a	n1	h1	H	H1	H2	D2	L1	TYPE		C1	n	h2
3	80	180	210	127.0	168.2	31.8	3/4-10	19.1	8	22.2	289	265	148	200	165	F07	70	4	9	37
4	100	190	273	157.2	215.9	38.1	7/8-9	22.2	8	25.4	370	330	180	300	270	F10	102	4	11	55
5	125	200	330	185.7	266.7	44.5	1-8	25.4	8	28.6	405	355	195	400	335	F14	140	4	18	86
6	150	210	356	215.9	292.1	47.8	1-8	25.4	12	28.6	420	370	225	400	335	F14	140	4	18	109
8	200	230	419	269.7	349.2	55.7	1 1/8-8	28.6	12	31.8	490	425	255	500	375	F16	165	4	22	192
10	250	250	508	323.9	431.8	63.5	1 1/4-8	31.8	16	35.1	545	480	310	500	375	F16	165	4	22	296
12	300	270	559	381.0	488.9	66.6	1 1/4-8	31.8	20	35.1	630	560	330	600	485	F25	254	8	18	421

※ NOT SPECIFIED CLASS AND SIZE, PLEASE CONTACT TO SALES DEPARTMENT

• NOTE

1. VALVE DESIGN : ASME B16.34
2. FACE TO FACE DIMENSION : ISO 5752 (SHORT TYPE)
3. END FLANGE DIMENSION : ASME B16.5

DOUBLE ECCENTRIC TYPE

High-Performance Type Butterfly Valves

- Extension of seat durability for double eccentricity (materialization row abrasion of seat)
- Easy changing seat and parts due to standard for all structures (reduce maintenance cost)

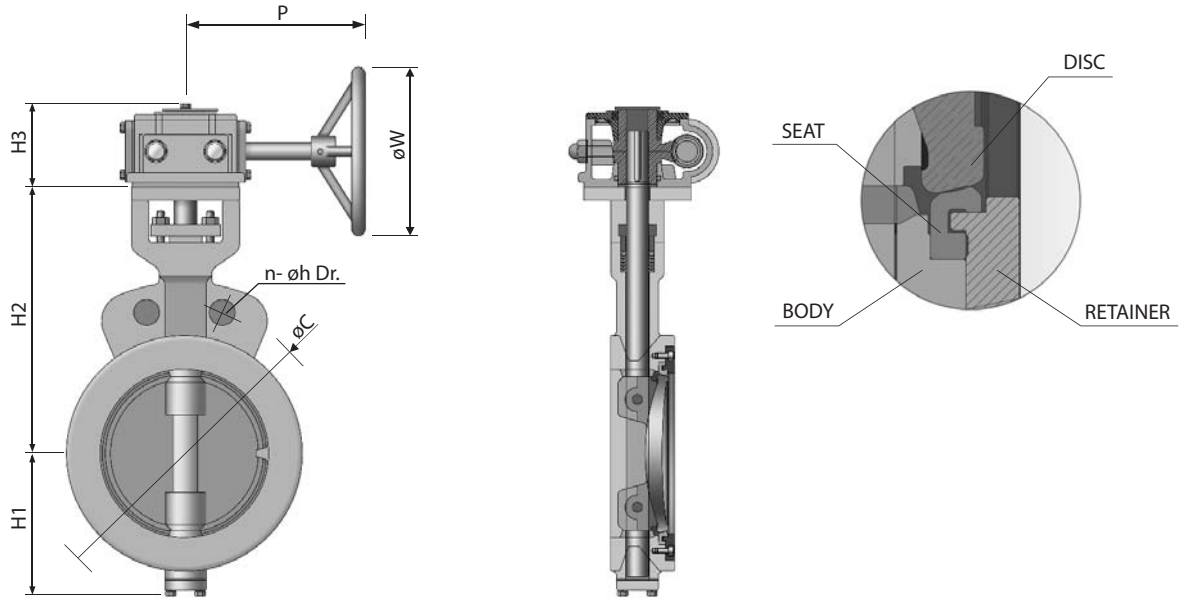

STANDARD MATERIAL SPECIFICATIONS

NO.	PART NAME	MATERIAL		
1	BODY	A216 WCB	A351 CF3M	B148 C95800
2	DISC	A351 CF8	A351 CF3M	B148 C95800
3	SEAT	PTFE	PTFE	PTFE
4	SHAFT	A276 304	A276 316L	A276 316
5	RETAINER BOLT	A193 Gr. B8	S.S 316L	A193 Gr. B8M
6	UPPER BUSH	316S.S+PTFE	316S.S+PTFE	316S.S+PTFE
7	LOWER BUSH	316S.S+PTFE	316S.S+PTFE	316S.S+PTFE
8	RETAINER	A240 304	A240 316L	A240 316
9	DISC PIN	A276 304	A276 316L	A276 316
10	PACKING GLAND	B584C83600	B584C83600	B584C83600
11	PACKING	TEFLON	TEFLON	TEFLON
12	END COVER	A36	A240 316L	B148C95800
13	GASKET	GRAPHITE	GRAPHITE	GRAPHITE
14	BRACKET	A36	A36	A36
15	GEAR BOX	ASS'Y	ASS'Y	ASS'Y
16	HAND WHEEL	A126CLB	A126CLB	A126CLB

DIMENSION AND WEIGHT

UNIT : mm

SIZE	2 1/2	3	4	5	6	
Ød	65	80	100	125	150	
L	46	48	54	56	57	
FLANGE RATING	ØC	139.7	152.4	190.5	215.9	241.3
	n-øh Dr.	4-Ø19	4-Ø19	8-Ø19	8-Ø22.3	8-Ø23
H1	75	83	94	95	127	
H2	167	177	195	218	237	
H3	75	75	75	75	75	
P	170	170	170	170	170	
ØW	150	150	150	150	150	

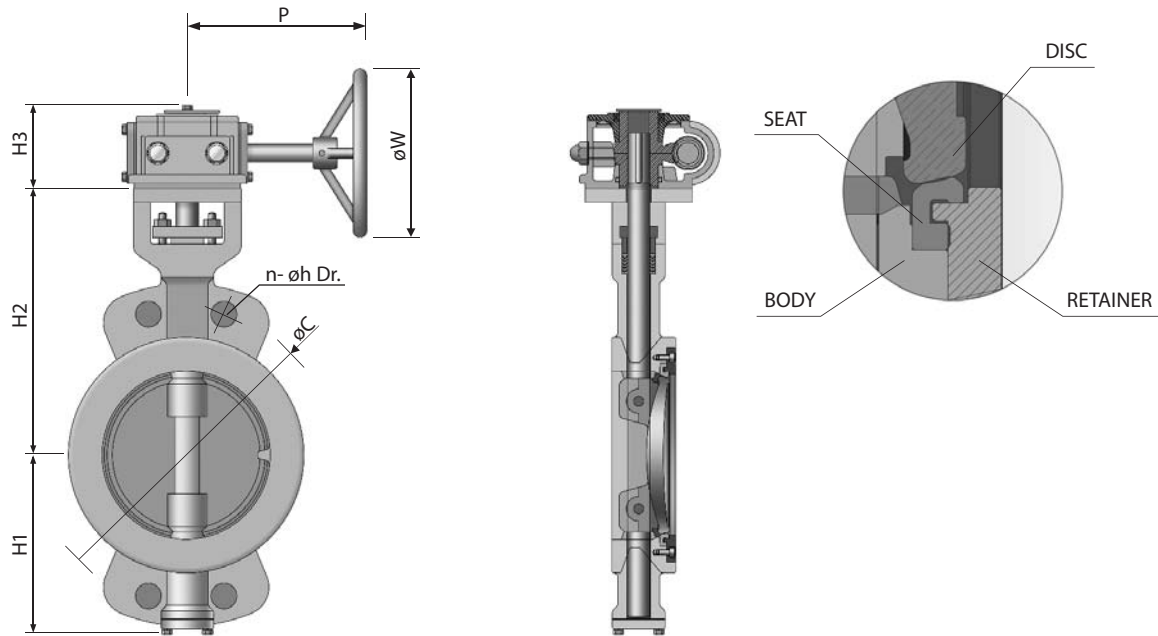

STANDARD MATERIAL SPECIFICATIONS

NO.	PART NAME	MATERIAL			
1	BODY	A216 WCB	A351 CF3M	B148 C95800	
2	DISC	A351 CF8	A351 CF3M	B148 C95800	
3	SEAT	PTFE	PTFE	PTFE	
4	SHAFT	A276 304	A276 316L	A276 316	
5	RETAINER BOLT	A193 Gr. B8	S.S 316L	A193 Gr. B8M	
6	UPPER BUSH	316S.S+PTFE	316S.S+PTFE	316S.S+PTFE	
7	LOWER BUSH	316S.S+PTFE	316S.S+PTFE	316S.S+PTFE	
8	RETAINER	A240 304	A240 316L	A240 316	
9	DISC PIN	A276 304	A276 316L	A276 316	
10	PACKING GLAND	B584C83600	B584C83600	B584C83600	
11	PACKING	TEFLON	TEFLON	TEFLON	
12	END COVER	A36	A240 316L	B148 C95800	
13	GASKET	GRAPHITE	GRAPHITE	GRAPHITE	
14	BRACKET	A36	A36	A36	
15	GEAR BOX	ASS'Y	ASS'Y	ASS'Y	
16	HAND WHEEL	A126CLB	A126CLB	A126CLB	

DIMENSION AND WEIGHT

UNIT : mm

SIZE	8	10	12	14	16	18	20	22	24	
Ød	200	250	300	350	400	450	500	550	600	
L	64	71	81	92	102	114	127	154	154	
FLANGE RATING	ØC	298.5	362.0	431.8	476.3	539.7	577.9	635.0	692.1	749.3
	n-Øh Dr.	8-Ø22.3	12-Ø25.4	12-Ø25.4	-	-	-	-	-	-
	n-h TAP	-	-	-	12-1"	16-1"	16-1 1/8"	20-1 1/8"	20-1 1/4"	20-1 1/4"
H1	196	237	264	305	345	372	420	440	471	
H2	295	337	360	331	461	489	565	628	654	
H3	100	100	100	109	109	126	126	142	142	
P	200	200	200	270	270	290	290	330	330	
ØW	250	250	250	310	310	390	390	390	390	

CONCENTRIC TYPE

Rubber Seat Butterfly Valves (Concentric Design)

- We intend from ceaseless technical development effort to zero leakage ratio and minimize valve torque. We manufacture to be used on optimum condition to various actuator of "pneumatic" etc.

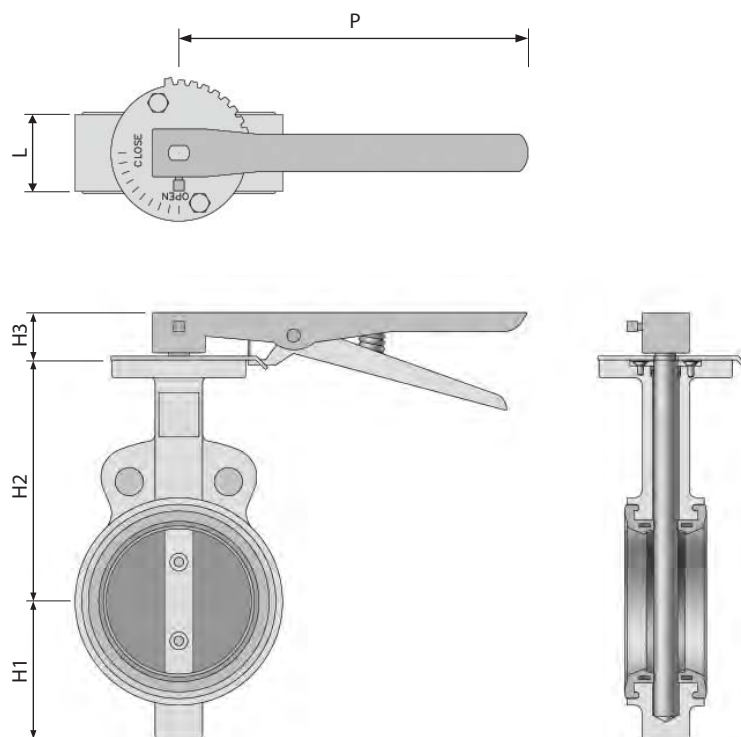

STANDARD MATERIAL SPECIFICATIONS

NO.	PART NAME	MATERIAL		
1	BODY	A216 WCB	A351 CF3M	B148 C95800
2	DISC	A351 CF8	A351 CF3M	B148 C95800
3	SEAT	EPDM	VITON	EPDM
4	SHAFT	A276 410	A276 316L	MONEL K500
5	DISC BOLT	A193 B8	S.S 316L	MONEL K500
6	PACKING	NBR	VITON	NBR
7	PACKING GLAND	A36	A240 316	A240 316
8	GLAND BOLT	A193 B7	A193 B8M	A193 B8M
9	LEVER	A36	S.S 304	S.S 304
10	INDICATOR	A36	S.S 304	S.S 304
11	LEVER BOLT	A193 B7	A193 B8M	A193 B8M

DIMENSION AND WEIGHT

SIZE	UNIT : mm					
	2	2 1/2	3	4	5	6
L	43	46	46	52	56	56
H1	58	65	78	93	116	128
H2	130	142	150	163	176	185
H3	34	34	34	34	34	34
P	233	233	262	262	262	262
WEIGHT(Kg)	4.5	5.5	6.0	6.5	8.5	10

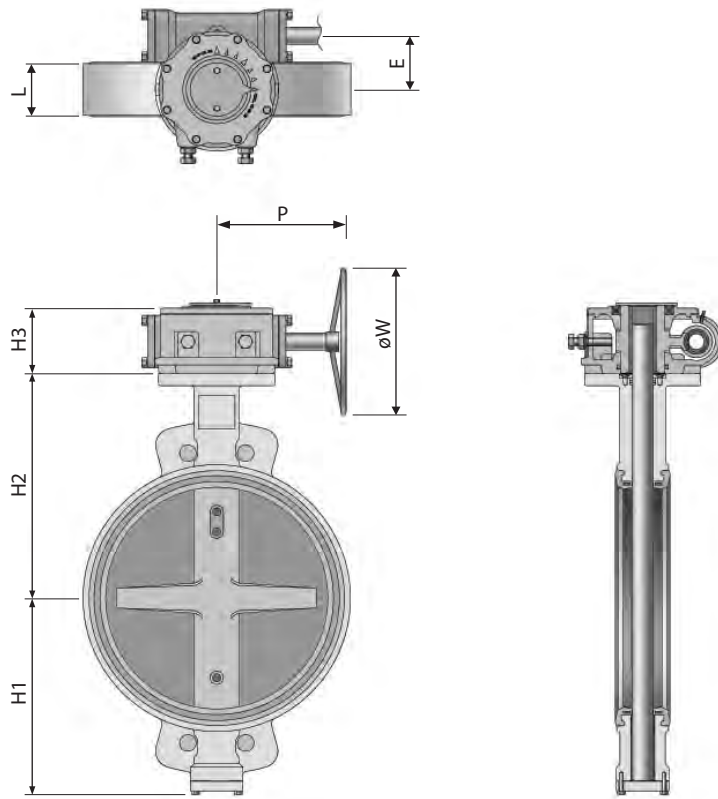

STANDARD MATERIAL SPECIFICATIONS

NO.	PART NAME	MATERIAL		
1	BODY	A216 WCB	A351 CF3M	B148 C95800
2	DISC	A351 CF8	A351 CF3M	B148 C95800
3	SEAT	EPDM	VITON	EPDM
4	SHAFT	A276 410	A276 316L	MONEL K500
5	DISC BOLT	A193 B8	S.S 316L	MONEL K500
6	PACKING	NBR	VITON	NBR
7	PACKING GLAND	A36	A240 316	A240 316
8	GLAND BOLT	A193 B7	A193 B8M	A193 B8M
9	END COVER	A36	A240 316L	B148 C95800
10	END COVER BOLT	A193 B7	A193 B8M	A193 B8M
11	GASKET	GRAPHITE	GRAPHITE	GRAPHITE
12	GEAR BOX	ASS'Y	ASS'Y	ASS'Y
13	HANDLE	A126 B	A126 B	A126 B
14	GEAR BOX BOLT	A193 B7	A193 B8M	A193 B8M

DIMENSION AND WEIGHT

UNIT : mm

SIZE	2	2 1/2	3	4	5	6	8	10	12	14	16	18	20	22	24
L	43	46	46	52	56	56	60	68	78	78	102	114	127	154	154
H1	58	65	78	93	116	128	155	231	267	297	332	350	394	430	455
H2	130	142	150	163	176	185	230	267	310	338	375	390	422	460	495
H3	29	29	29	29	29	29	45	36	36	45	45	45	55	55	65
P	150	150	150	150	150	150	200	200	200	270	270	270	290	290	330
E	44	44	44	44	44	44	65	65	65	80	80	80	85	85	103
ØM	150	150	150	150	150	150	250	250	250	310	310	310	390	390	390
WEIGHT(Kg)	6.5	7.0	7.5	8.5	10.5	11.5	15.5	31	42	50	93	110	165	230	300

MEMO

Fully Integrated, Yet Flexible
PKvalve

BALL VALVES

- *FLOATING BALL*

- *TRUNNION BALL*



BALL VALVES

DESIGN AND TEST

Ball valves are designed, constructed and tested according to API-6D standards.

DOUBLE BLOCK AND BLEED

All trunnion mounted type ball valves employ a sealing principle that facilitates all services requiring double block and bleed integrity.

DOUBLE PISTON EFFECT

On request the seat rings design may be modified to perform the double piston effect action. In this case the pressure acting on both the external and internal side of the seat rings, results in force pushing the gams against the ball, therefore each seat rings grants the required tightness even if the pressure is applied in the body cavity. This feature adds an extra sealing feature to the valve, but to release the possible over pressure developed into the body cavity it is necessary to use an external safety relief valve.

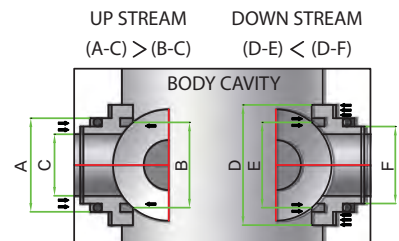

DOUBLE PISTON EFFECT

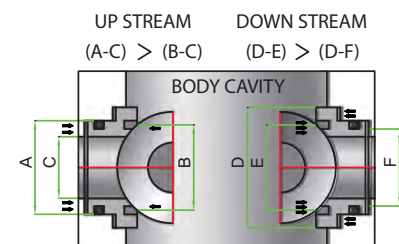

SELF RELIEVING

SEALING PRINCIPLE

All model trunnion mounted type ball valves are supplied with spring-loaded seats to ensure that the seats are always in contact with the ball. this design provides a very efficient seal even at low line pressure. As the line pressure increases, the seat is forced into tighter contact with the ball providing a positive shut-off.

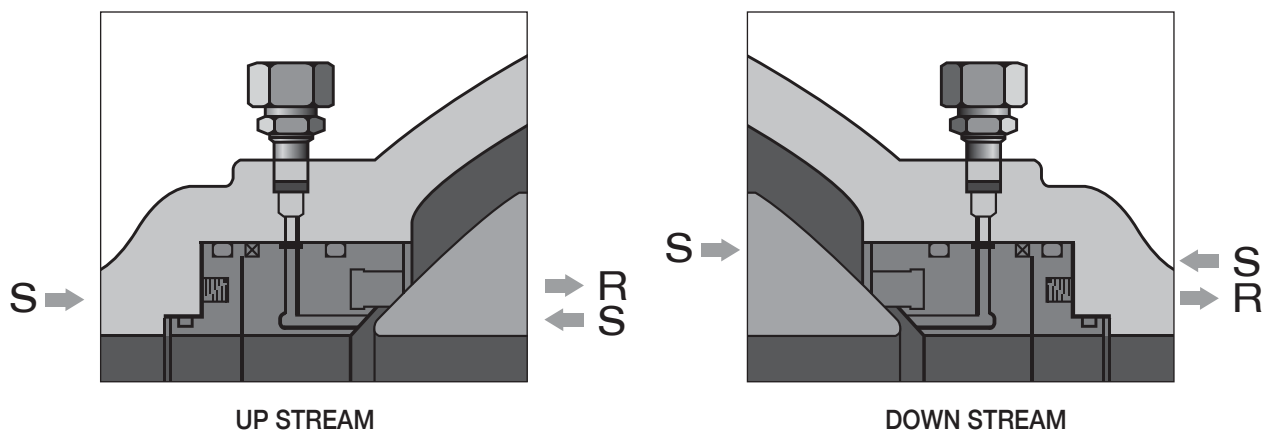

FIRE SAFE CONSTRUCTION

The secondary metal seat is provided to contact between the seat and ball in the event the primary non-metallic seat is destroyed by fire all trunnion mounted type ball valves are fire-safe designed. The double body and cap seals provide maximum security. It is fitted with special graphite seals so as to effectively preclude leakage in the event of fire. All top trunnion mounted ball valves have been tested to API-607 and API-6FA

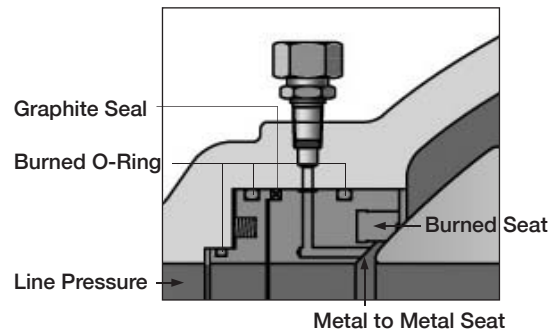

SECONDARY SEAT AND STEM SEALING OPTION

All model trunnion mounted type ball valves are designed to provide high integrity shut-off. Upon request, sealant lubrication fittings are installed. In the event of seat insert or stem seal damage, external or internal leakage can occur. Emergency sealant injection can save the integrity of the valve by incorporating a sealant seal around the stem or between the seat and the ball until such time the valve may be properly serviced.

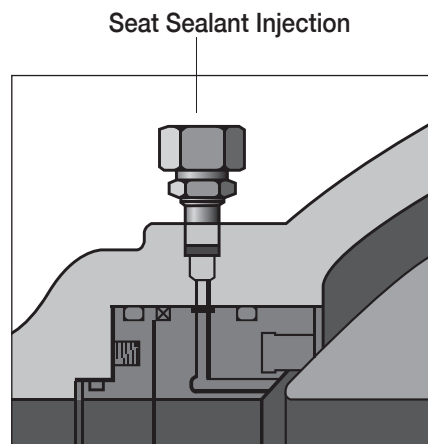
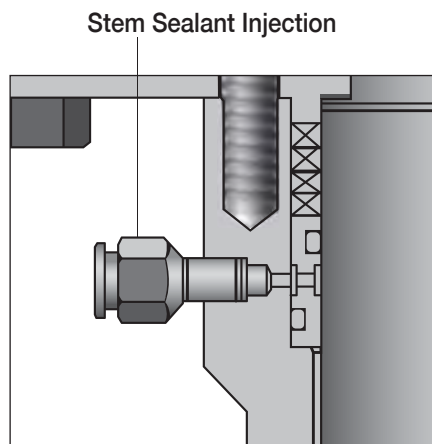

AT ALL TIMES-STEM SEAL

This option provides premier valve stem sealing characteristics for adverse conditions of extreme pressure/temperature variations. Designed to meet the most stringent fugitive emission regulations, design is comprised of an extra deep stuffing box/packing/stem seal retainer & conical disc spring. The disc spring provide continuous compression of the packing assembly and compensate for wear.

ACTUATOR MOUNTING ISO 5211

All top flanged end products shall have an integrally cast (ISO) actuator mounting pad. This feature provides for direct mount of gear operators or electric actuators. The additional cast for separate mounting bracket is eliminated.

STATIC SEALED STEM SEAL RETAINER

The stem seal retainer, with its (2) static viton o-ring seals; Accepts the forces provided by the combination iso mounting pad/packing gland & transmits those forces as packing/disc spring factory pre-load. A variety of o-ring seals are available for those exceptionally demanding applications. Field maintenance & costly repairs are virtually eliminated.

SPRING FORCE

Optional conical disc springs insure adequate loading of packing at all times. Excessive stem torque and packing deformation due to over-tightening of conventional packing glands is eliminated. The constant "LOAD" provided by the disc springs compensates for normal wear-repair and maintenance costs are virtually eliminated.

PACKING

The high pressure/high temperature packing set is comprised of self-cleaning, die-formed, high-density and low-density graphite molded packing materials. This unique design eliminates stem galling, lowers required valve stem torque and increases product performance.

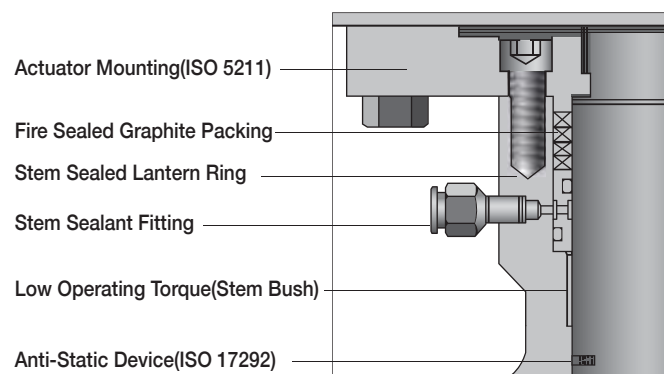

ANTI-STATIC DESIGN ISO 17292

Ball valves present a particular problem with the build up of static electricity around the ball. They have anti-static design which provides contact between stem and ball, and stem and body to eliminate static electricity.

TRUNNION LOW STEM DESIGN

Trunnion mount design locates the low stem trunnion assembly within the confines of body & cap. In so doing, both the line pressure and media act upon all valve cavity components equally.

The advantages of such a design include:

1. The pressure & media does not concentrate in one location only, instead the forces are dispersed equally throughout the pressurized areas.
2. Ball movement and side loading of lower stem is minimized, thereby decreasing operational torque valves and improving stem seal life end.
3. Guarantee the low torque and extend valve life.

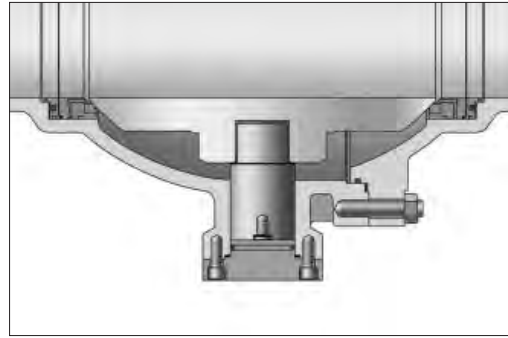

UNIQUE DOUBLE SEALING DESIGN AND METAL TO METAL CONTACT

The PTFE gasket acts as the primary seal for top unibody ball valves. the secondary seal is made of flexible graphite; A material with extremely good resistance to fire conditions.

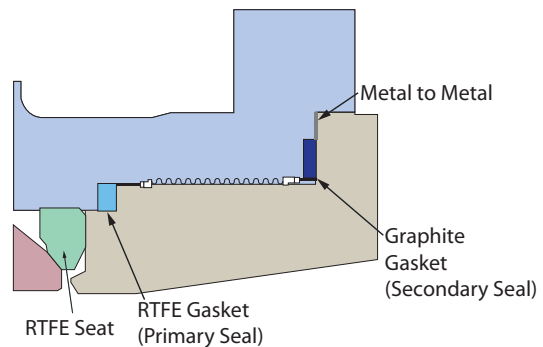

APPLICATION OF SEAT PER TEMPERATURE

CLASS	SEAT METARIAL	DESIGN TEMPERATURE
150#	RTFE	- 50°C ~ +180°C
300#	RTFE	- 50°C ~ +150°C
600#	RTFE	- 50°C ~ +100°C
900#	NYLON(DEVLON)	- 45°C ~ +190°C
1500#	NYLON(DEVLON)	- 45°C ~ +170°C
2500#	NYLON(DEVLON)	- 45°C ~ +160°C
ALL CLASS	PEEK	200°C & OVER
ALL CLASS	METAL	250°C & OVER

FLOATING BALL, FULL BORE ASME CLASS 150#, 300#, 600#

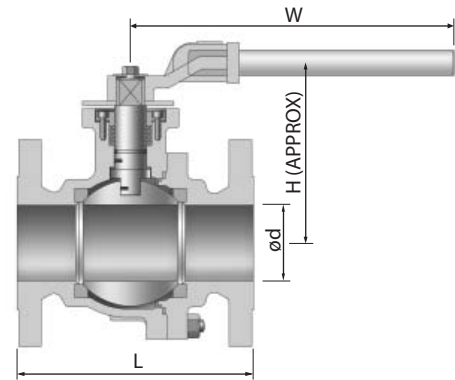
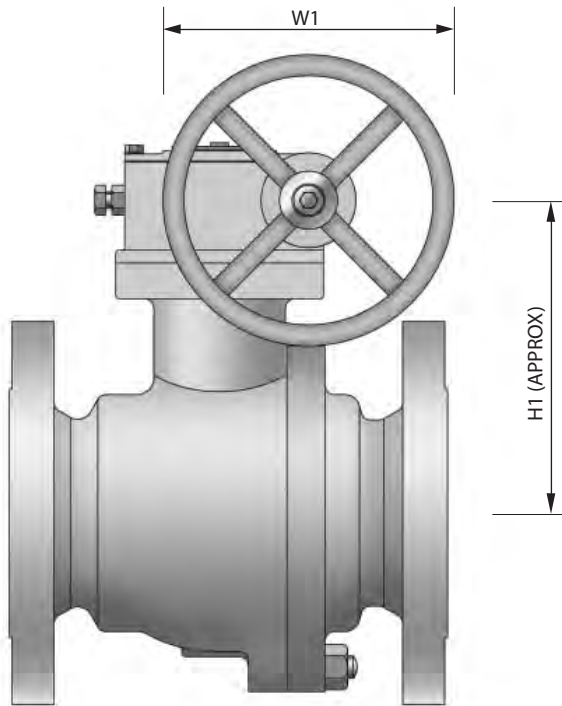

END CONNECTION

- R.F FLANGED ENDS TO ASME B16.5
- B.W. ENDS TO ASME B16.25
- R.T.J FLANGED ENDS TO ASME B16.5
- SIZE 26" AND LARGER, FLANGED ENDS ACCORDING TO ASME B16.47 SER.A OR SER.B
- CONSULT US FOR LARGER SIZE

STANDARD MATERIAL SPECIFICATIONS

NO.	PART NAME	MATERIAL
1	BODY	A216 - WCB
2	CAP	A216 - WCB
3	BALL	A351-CF8M
4	STEM	A276-316
5	PACKING GLAND	A276-316
6	SEAT RING	RTFE
7	PACKING	GRAPHITE
8	THRUST BEARING(STEM)	PTFE
9	CAP GASKET	GRAPHITE
10	CAP BOLT	A193-B7
11	NUT	A194-2H
12	O-RING(CAP)	VITON
13	O-RING(STEM)	VITON
14	GLAND BOLT	A193-B7
15	STOP BOLT	A193-B7
16	LEVER BOLT	A283-D+GAL'V
17	STOPPER	A283-D+GAL'V
18	WASHER	A307-B
19	LEVER	CARBON STEEL
20	ANTI STATIC	316SS

DIMENSION AND WEIGHT

CLASS 150

UNIT : mm

SIZE	B	1/2	3/4	1	1 1/2	2	3	4	6	8
Ød		15	20	25	38	50	76	100	152	203
L	RF	108	117	127	165	178	203	229	394	457
	RTJ	-	-	-	178	190	216	241	406	470
	BW	-	-	-	190	216	282	305	457	521
H		90	100	106	128	145	195	215	285	337
H1		-	-	-	-	-	178	198	258	325
W		180	180	230	250	250	350	350	450	500
W1		-	-	-	-	-	250	250	300	400
APPROX(Kg)/ WEIGHT(RF)		2.2	3.2	4.8	8.2	11.5	28.5	42.0	84.5	152.0

CLASS 300

UNIT : mm

SIZE	B	1/2	3/4	1	1 1/2	2	3	4	6	8
Ød		15	20	25	38	50	76	100	152	203
L	RF	140	152	165	190	216	282	305	403	502
	RTJ	-	-	-	203	232	298	321	419	517
	BW	-	-	-	190	216	282	305	457	521
H		90	100	106	128	145	195	215	285	337
H1		-	-	-	-	-	178	198	258	325
W		180	180	230	250	250	350	350	450	500
W1		-	-	-	-	-	250	250	300	400
APPROX(Kg)/ WEIGHT(RF)		2.8	3.8	5.6	10.5	15.0	33.0	50.5	108.0	184.0

CLASS 600

UNIT : mm

SIZE	B	1/2	3/4	1	1 1/2	2	3	4	6	8
Ød		15	20	25	38	50	76	100	152	203
L	RF	165	191	216	241	292	356	432	559	660
	RTJ	165	191	216	241	295	359	435	562	664
	BW	165	191	216	241	292	356	432	559	660
H		90	100	106	128	148	201	220	290	340
H1		-	-	-	-	-	182	202	263	335
W		180	180	230	250	250	400	500	700	1000
W1		-	-	-	-	-	250	250	300	400
APPROX(Kg)/ WEIGHT(RF)		3.7	5.6	7.8	13.5	27.5	53.6	93.0	178.5	340.5

FLOATING BALL, FULL BORE ASME CLASS 900#, 1500#

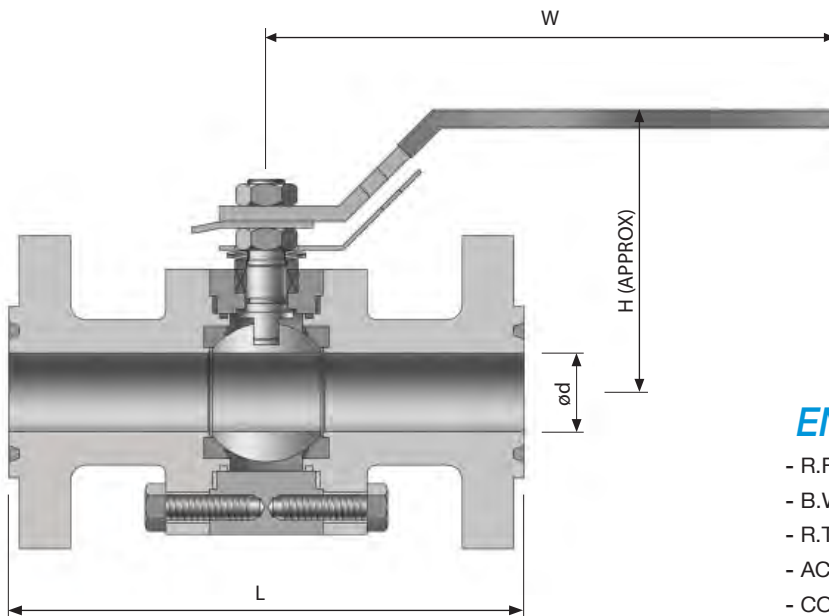

END CONNECTION

- R.F FLANGED ENDS TO ASME B16.5
- B.W. ENDS TO ASME B16.25
- R.T.J FLANGED ENDS TO ASME B16.5
- ACCORDING TO ASME B16.47 SER.A OR SER.B
- CONSULT US FOR LARGER SIZE

STANDARD MATERIAL SPECIFICATIONS

NO.	PART NAME	MATERIAL
1	BODY	A105
2	CAP	A105
3	BALL	A276-316
4	STEM	A564-630
5	SEAT RING	NYLON
6	PACKING GLAND	A276-316
7	CAP BOLT	A193-B7
8	LEVER NUT	A194-2H
9	STEM NUT	A194-2H
10	STOPPER	A283D+GAL'V
11	LOCKING DEVICE	A283D+GAL'V
12	PACKING	GRAPHITE
13	GASKET	GRAPHITE
14	SEAT SEAL	GRAPHITE
15	BACK SEAT	GRAPHITE
16	O-RING(CAP)	VITON
17	O-RING(SEAT)	VITON
18	THRUST WASHER	RTFE
19	ANTI STATIC DEVICE	316SS
20	CONICAL SPRING	C.S+GAL'V
21	LEVER	A108-1020+VINYL

DIMENSION AND WEIGHT

CLASS 900 / 1500

UNIT : mm

SIZE	B	1/2	3/4	1	1 1/2
Ød		13	20	25	38
L	RF	216	229	254	305
	RTJ	216	229	254	305
	BW	216	229	254	305
H		95	100	110	118
W		180	180	230	250
APPROX(Kg)/ WEIGHT(RF)		2.2	3.2	4.8	8.2

FLOATING BALL, REDUCED BORE ASME CLASS 150#, 300#, 600#

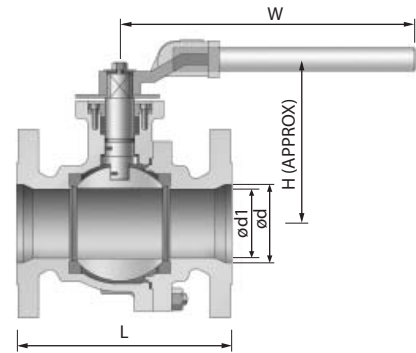
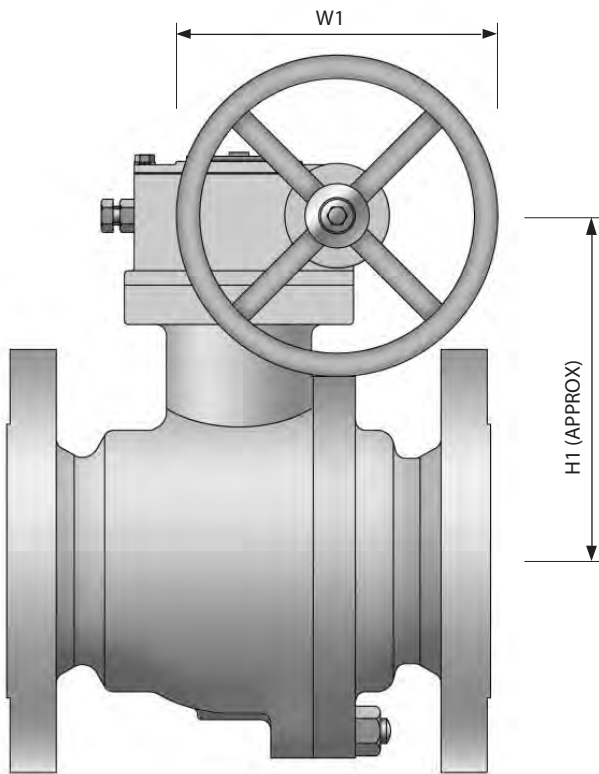

END CONNECTION

- R.F FLANGED ENDS TO ASME B16.5
- B.W. ENDS TO ASME B16.25
- R.T.J FLANGED ENDS TO ASME B16.5
- SIZE 26" AND LARGER, FLANGED ENDS ACCORDING TO ASME B16.47 SER.A OR SER.B
- CONSULT US FOR LARGER SIZE

STANDARD MATERIAL SPECIFICATIONS

NO.	PART NAME	MATERIAL
1	BODY	A216 - WCB
2	CAP	A216 - WCB
3	BALL	A351-CF8M
4	STEM	A276-316
5	PACKING GLAND	A276-316
6	SEAT RING	RTFE
7	PACKING	GRAPHITE
8	THRUST BEARING(STEM)	PTFE
9	CAP GASKET	316/GRAPHITE
10	CAP BOLT	A193-B7
11	NUT	A194-2H
12	O-RING(CAP)	VITON
13	O-RING(STEM)	VITON
14	GLAND BOLT	A193-B7
15	STOP BOLT	A193-B7
16	LEVER BOLT	A283-D+GAL'V
17	STOPPER	A283-D+GAL'V
18	WASHER	A307-B
19	LEVER	CARBON STEEL
20	ANTI STATIC	316SS

DIMENSION AND WEIGHT

CLASS 150

UNIT: mm

SIZE	B	1/2	3/4	1	1 1/2	2	3	4	6	8	10
Ød		15	20	25	38	50	76	100	152	203	252
Ød1		13	15	20	25	38	50	76	100	152	203
L	RF	108	117	127	165	178	203	229	394	457	533
	RTJ	-	-	-	178	190	216	241	406	470	546
	BW	-	-	-	190	216	282	305	457	521	559
H		90	90	100	106	128	145	195	215	285	337
H1		-	-	-	-	-	-	178	198	258	325
W		180	180	180	230	250	250	350	350	450	500
W1		-	-	-	-	-	-	250	250	300	400
APPROX(Kg)/ WEIGHT(RF)		2.2	2.8	3.5	5.2	10.2	22.5	32.5	52.5	105.5	180.5

CLASS 300

UNIT: mm

SIZE	B	1/2	3/4	1	1 1/2	2	3	4	6	8	10
Ød		15	20	25	38	50	76	100	152	203	252
Ød1		13	15	20	25	38	50	76	100	152	203
L	RF	140	152	165	190	216	282	305	403	502	568
	RTJ	-	-	-	203	232	298	321	419	517	584
	BW	-	-	-	190	216	282	305	457	521	559
H		90	90	100	106	128	145	195	215	285	337
H1		-	-	-	-	-	-	178	198	258	325
W		180	180	180	230	250	250	350	350	450	500
W1		-	-	-	-	-	-	250	250	300	400
APPROX(Kg)/ WEIGHT(RF)		2.8	3.2	4.6	8.5	13.2	31.0	42.5	79.8	135.0	220.5

CLASS 600

UNIT: mm

SIZE	B	1/2	3/4	1	1 1/2	2	3	4	6	8
Ød		15	20	25	38	50	76	100	152	203
Ød1		13	15	20	25	38	50	76	100	152
L	RF	165	191	216	241	292	356	432	559	660
	RTJ	165	191	216	241	295	359	435	562	663
	BW	165	191	216	241	292	356	432	559	660
H		90	90	100	106	128	148	201	220	290
H1		-	-	-	-	-	-	182	202	263
W		180	180	180	230	250	250	400	500	700
W1		-	-	-	-	-	-	250	250	300
APPROX(Kg)/ WEIGHT(RF)		3.7	4.8	6.5	9.8	18.5	30.5	67.8	122.5	182.5

TRUNNION BALL, FULL BORE ASME CLASS 150#, 300#, 600#

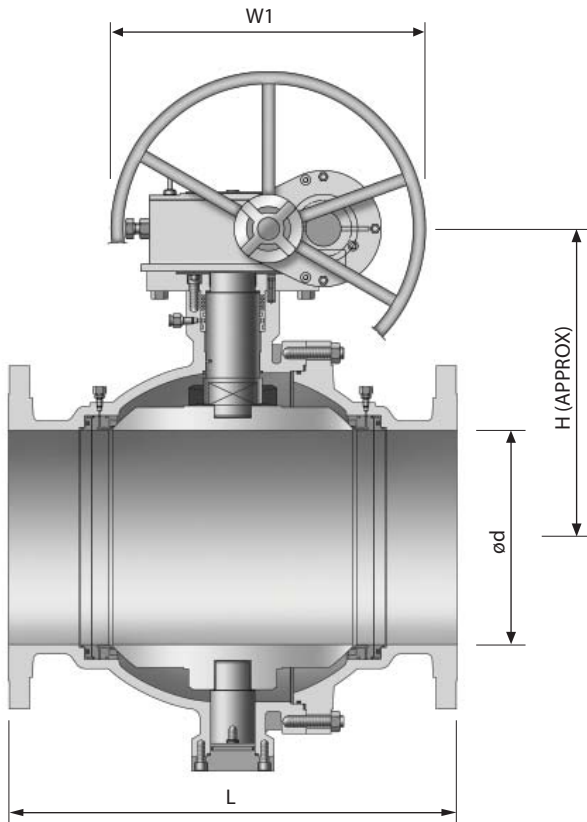

END CONNECTION

- R.F FLANGED ENDS TO ASME B16.5
- B.W. ENDS TO ASME B16.25
- R.T.J FLANGED ENDS TO ASME B16.5
- SIZE 26" AND LARGER, FLANGED ENDS ACCORDING TO ASME B16.47 SER.A OR SER.B
- CONSULT US FOR LARGER SIZE

STANDARD MATERIAL SPECIFICATIONS

NO.	PART NAME	MATERIAL
1	BODY	A216-WCB
2	CAP	A216-WCB
3	LOWER COVER	A216-WCB
4	BALL	A351-CF8M
5	SEAT RETAINER	A351-CF8M
6	STEM	A276-316
7	LOWER STEM	A276-316
8	LANTERN RING	A276-316
10	CAP BOLT	A193-B7
11	NUT	A194-2H
12	LOWER COVER BOLT	A193-B7
13	PAD BOLT	A193-B7
14	SEAT RING	RTFE
15	PACKING	GRAPHITE
16	CAP GASKET	GRAPHITE
17	LOWER COVER GASKET	GRAPHITE
18	FIRE SAFE SEAL	GRAPHITE
19	THRUST BEARING	DU-BUSH
21	STEM BEARING	DU-BUSH
22	LOWER STEM BEARING	DU-BUSH
23	PAD BEARING	DU-BUSH
24	O-RING	VITON
31	SPRING	INCONEL-X750
32	PIN	316SS
33	GEAR BOX	DUCTILE
34	STEM SEALANT FITTING	316SS
35	DRAIN PLUG	316SS

DIMENSION AND WEIGHT

CLASS 150

UNIT : mm

SIZE	B	10	12	14	16	18	20	24
$\varnothing d$		254	305	337	387	438	489	591
L	RF	533	610	686	762	864	914	1067
	RTJ	546	622	698	775	876	927	1079
	BW	559	635	762	838	914	991	1143
H		356	415	485	550	598	640	745
W		500	500	560	560	710	710	800
APPROX(Kg)/ WEIGHT(RF)		272	473	571	875	938	1525	2152

CLASS 300

UNIT : mm

SIZE	B	10	12	14	16	18	20	24
$\varnothing d$		254	305	337	387	438	489	591
L	RF	568	648	762	838	914	991	1143
	RTJ	584	664	778	854	930	1010	1165
	BW	559	635	762	838	914	991	1143
H		362	420	490	555	603	645	750
W		500	500	560	560	710	710	800
APPROX(Kg)/ WEIGHT(RF)		303	502	602	1005	1158	1825	2558

CLASS 600

UNIT : mm

SIZE	B	10	12	14	16	18	20	24
$\varnothing d$		254	305	337	387	438	489	591
L	RF	787	838	889	991	1092	1194	1397
	RTJ	791	841	892	994	1095	1200	1406
	BW	787	838	889	991	1092	1194	1397
H		425	475	540	610	655	710	815
W		560	560	630	710	800	800	900
APPROX(Kg)/ WEIGHT(RF)		552	787	849	1489	2172	2628	3392

TRUNNION BALL, FULL BORE ASME CLASS 150#, 300#, 600#

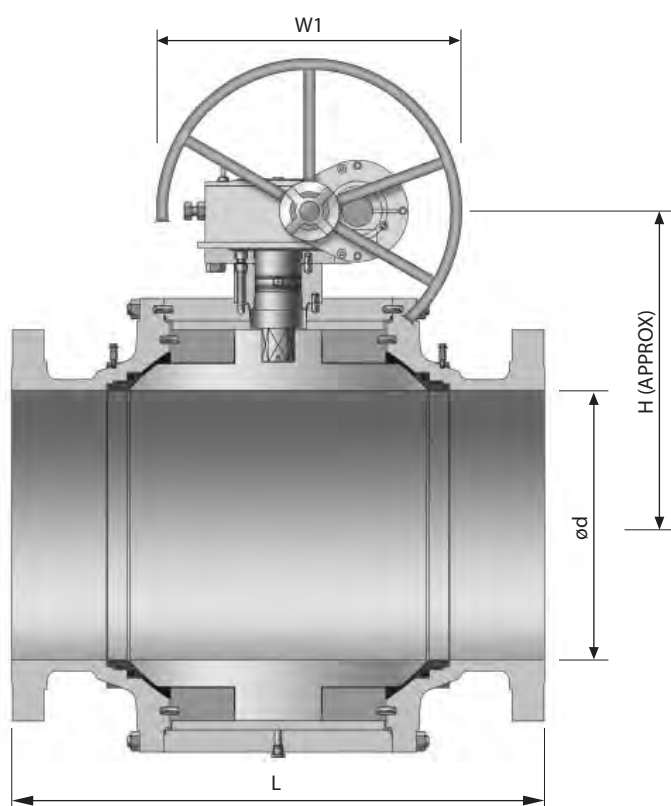

END CONNECTION

- R.F FLANGED ENDS TO ASME B16.5
- B.W. ENDS TO ASME B16.25
- R.T.J FLANGED ENDS TO ASME B16.5
- SIZE 26" AND LARGER, FLANGED ENDS ACCORDING TO ASME B16.47 SER.A OR SER.B
- CONSULT US FOR LARGER SIZE

STANDARD MATERIAL SPECIFICATIONS

NO.	PART NAME	MATERIAL
1	BODY	A216-WCB or A105
2	CAP	A216-WCB or A105
3	BALL	A315-CF8M
4	STEM	A276-316
5	SEAT RING	RTFE
6	PACKING	GRAPHITE
7	CAP GASKET	GRAPHITE
8	GLAND GASKET	GRAPHITE
9	FIRE SAFE SEAL	GRAPHITE
10	SEAT RETAINER	A351-CF8M
11	TRUNNION PLATE	A105+ENP
12	GLAND	AISI-1020
14	STEM BEARING	DU-BUSH
16	TRUNNION BEARING	DU-BUSH
17	PAD BEARING	DU-BUSH
18	THRUST BEARING	DU-BUSH
20	O-RING	VITON
25	CAP BOLT	A193-B7
26	NUT	A914-2H
27	GLAND BOLT	A193-B7
28	PAD BOLT	A193-B7
29	PIN	A276-316
33	SPRING	INCONEL-X750
34	GEAR BOX	DUCTILE
35	STEM SEALANT FITTING	316SS
36	DRAIN PLUG	316SS

DIMENSION AND WEIGHT

CLASS 150

UNIT : mm

SIZE	B	16	18	20	24	26	28	30	32	34	36
$\varnothing d$		387	438	489	591	635	686	737	781	832	876
L	RF	762	864	914	1067	1143	1244	1295	1371	1473	1524
	RTJ	775	876	927	1079	-	-	-	-	-	-
	BW	838	914	991	1143	1245	1346	1397	1524	1626	1727
H		503	515	553	585	685	723	778	906	920	955
W1		560	710	710	800	800	900	900	900	900	900
APPROX(Kg)/ WEIGHT(RF)		870	1210	1850	3180	3770	4635	5370	6960	7950	8950

CLASS 300

UNIT : mm

SIZE	B	16	18	20	24	26	28	30	32	34	36
$\varnothing d$		387	438	489	591	635	686	737	781	832	876
L	RF	838	914	991	1143	1245	1346	1397	1524	1626	1727
	RTJ	854	930	1010	1165	1270	1372	1422	1553	1654	1756
	BW	838	914	991	1143	1245	1346	1397	1524	1626	1727
H		513	525	565	595	705	745	798	926	940	975
W1		560	710	710	800	800	900	900	900	900	900
APPROX(Kg)/ WEIGHT(RF)		1480	1685	2290	3610	4810	5920	6740	8080	9260	10280

CLASS 600

UNIT : mm

SIZE	B	16	18	20	24	26	28	30	32	34	36
$\varnothing d$		387	438	489	591	635	686	737	781	832	876
L	RF	991	1092	1194	1397	1448	1549	1651	1778	1930	2083
	RTJ	994	1095	1200	1406	1460	1562	1664	1794	1946	2098
	BW	991	1092	1194	1397	1448	1549	1651	1778	1930	2083
H		518	535	575	605	615	755	815	940	956	995
W1		710	800	800	900	800	900	900	900	900	900
APPROX(Kg)/ WEIGHT(RF)		1580	2180	2780	3930	5830	6940	8560	9940	11570	13530

TRUNNION BALL, FULL BORE ASME CLASS 900#, 1500#

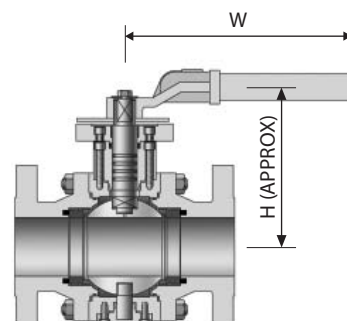
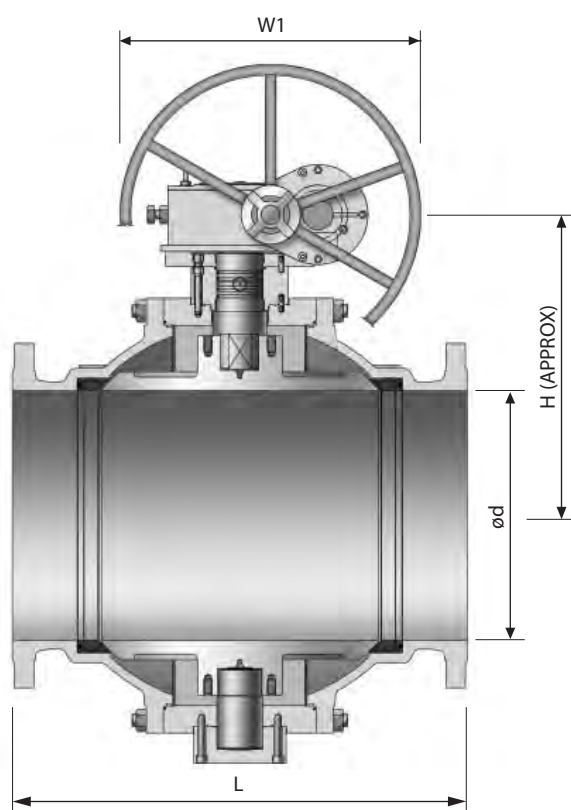

END CONNECTION

- R.F FLANGED ENDS TO ASME B16.5
- B.W. ENDS TO ASME B16.25
- R.T.J FLANGED ENDS TO ASME B16.5
- SIZE 26" AND LARGER, FLANGED ENDS ACCORDING TO ASME B16.47 SER.A OR SER.B
- CONSULT US FOR LARGER SIZE

STANDARD MATERIAL SPECIFICATIONS

NO.	PART NAME	MATERIAL
1	BODY	A215 WCB or A105
2	CAP	A216-WCB
3	BALL	A351-CF8M
4	STEM	A564-630
5	LOWER STEM	A564-630
6	SEAT POCKET	A351-CF8M
7	SEAT RETAINER	A351-CF8M
8	LOWER COVER	A105
9	GLAND	AISI-1020
11	SEAT RING	NYLON
12	PACKING	GRAPHITE
13	CAP GASKET	GRAPHITE
14	LOWER COVER GASKET	GRAPHITE
15	GLAND GASKET	GRAPHITE
16	SEAT POCKET SEAL	GRAPHITE
17	STEM BEARING	DU-BUSH
19	PAD BEARING	DU-BUSH
20	LOWER STEM BEARING	DU-BUSH
21	THRUST BEARING	DU-BUSH / PTFE
23	O-RING	VITON
28	CAP BOLT	A193-B7
29	NUT	A914-2H
30	LOWER COVER BOLT	A193-B7
31	GLAND BOLT	A193-B7
32	PAD BOLT	A193-B7
33	PIN	A276-316
35	SPRING	INCONEL-X750
36	GEAR BOX	DUCTILE

DIMENSION AND WEIGHT

CLASS 900

UNIT : mm

SIZE	B	2	3	4	6	8	10	12
Ød		50	76	100	152	203	254	305
L	RF	368	381	457	610	737	838	965
	RTJ	371	384	460	613	740	841	968
	BW	368	381	457	610	737	838	965
H		205	235	270	-	-	-	-
H1		155	178	264	325	355	450	520
W		300	400	500	-	-	-	-
W1		300	300	400	630	630	630	630
APPROX(Kg)/ WEIGHT(RF)		52.0	81.0	170.0	390.0	640.0	1070.0	1610.0

CLASS 1500

UNIT : mm

SIZE	B	2	3	4	6	8	10	12
Ød		50	76	100	152	203	254	305
L	RF	368	470	546	705	832	991	1130
	RTJ	371	473	549	711	841	1000	1146
	BW	368	470	546	705	832	991	1130
H		205	240	275	-	-	-	-
H1		160	183	270	350	410	465	565
W		300	400	500	-	-	-	-
W1		300	300	400	630	630	710	710
APPROX(Kg)/ WEIGHT(RF)		52.0	105.0	205.0	525.0	880.0	1560.0	2355.0

TRUNNION BALL, FULL BORE ASME CLASS 900#, 1500#

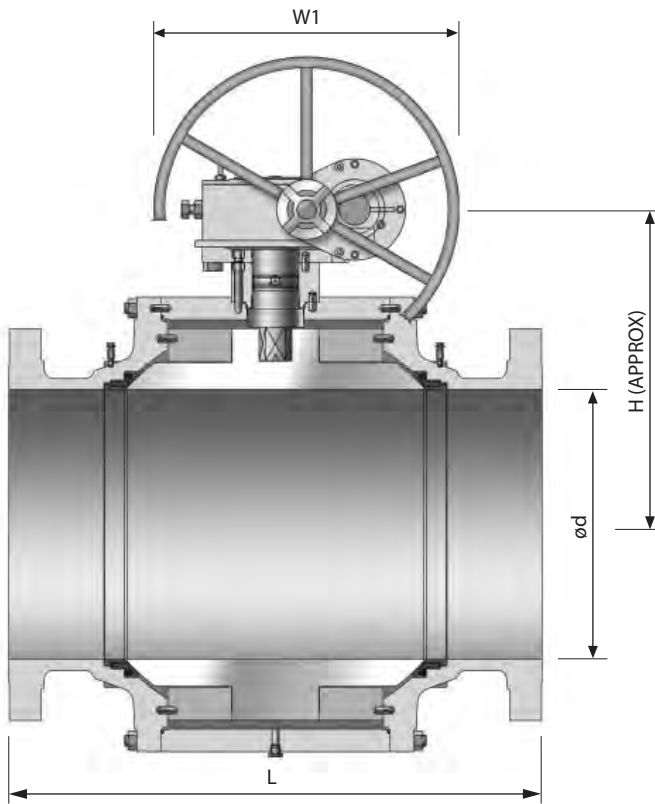

END CONNECTION

- R.F FLANGED ENDS TO ASME B16.5
- B.W. ENDS TO ASME B16.25
- R.T.J FLANGED ENDS TO ASME B16.5
- SIZE 26" AND LARGER, FLANGED ENDS ACCORDING TO ASME B16.47 SER.A OR SER.B
- CONSULT US FOR LARGER SIZE

STANDARD MATERIAL SPECIFICATIONS

NO.	PART NAME	MATERIAL
1	BODY	A215 WCB or A105
2	CAP	A215 WCB or A105
3	BALL	A351-CF8M
4	STEM	A276-316
5	SEAT RING	RTFE
6	PACKING	GRAPHITE
7	CAP GASKET	GRAPHITE
8	GLAND GASKET	GRAPHITE
9	FIRE SAFE SEAL	GRAPHITE
10	SEAT RETAINER	A351-CF8M
11	TRUNNION PLATE	A105+ENP
12	GLAND	AISI-1020
14	STEM BEARING	DU-BUSH
16	TRUNNION BEARING	DU-BUSH
17	PAD BEARING	DU-BUSH
18	THRUST BEARING	DU-BUSH
20	O-RING	VITON
25	CAP BOLT	A193-B7
26	NUT	A914-2H
27	GLAND BOLT	A193-B7
28	PAD BOLT	A193-B7
29	PIN	A276-316
33	SPRING	INCONEL-X750
34	GEAR BOX	DUCTILE
35	STEM SEALANT FITTING	316SS
36	DRAIN PLUG	316SS

DIMENSION AND WEIGHT

CLASS 900

UNIT : mm

SIZE	B	8	10	12	14	16	18	20	24
$\varnothing d$		203	254	305	324	375	425	473	571
L	RF	737	838	965	1029	1130	1219	1321	1549
	RTJ	740	841	968	1038	1140	1232	1333	1568
	BW	737	838	965	1029	1130	1219	1321	1549
H		396	485	531	600	620	700	750	840
W1		630	710	800	900	900	900	1000	1000
APPROX(Kg)/ WEIGHT(RF)		645	1070	1610	1560	2240	3000	4360	7030

CLASS 1500

UNIT : mm

SIZE	B	8	10	12	14	16	18	20	24
$\varnothing d$		194	241	289	317	362	407	457	534
L	RF	832	991	1130	1257	1384	1537	1664	2043
	RTJ	841	1000	1146	1276	1406	1559	1686	2071
	BW	832	991	1130	1257	1384	1537	1664	2043
H		410	495	565	605	625	710	760	850
W1		630	710	800	900	900	900	1000	1000
APPROX(Kg)/ WEIGHT(RF)		880	1560	2355	3020	4260	6400	9300	14550

TRUNNION BALL, REDUCED BORE ASME CLASS 150#, 300#, 600#

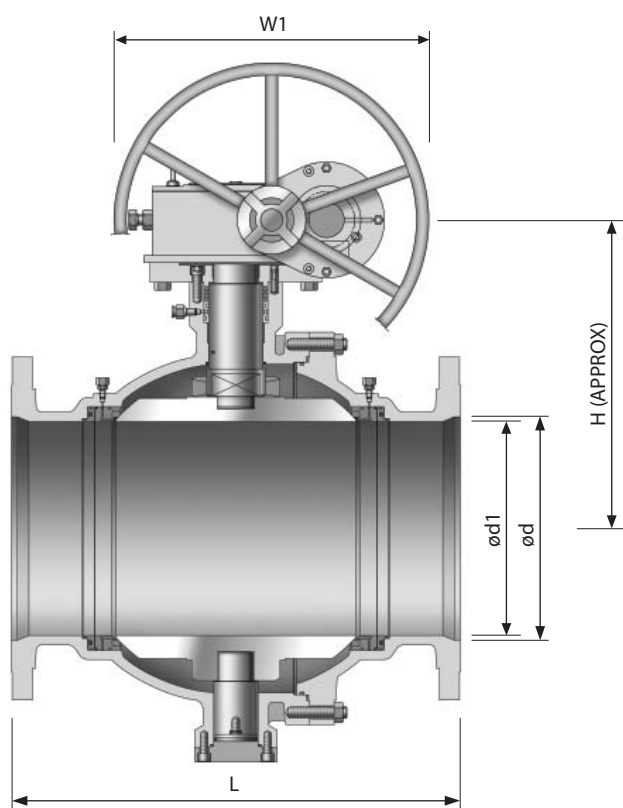

END CONNECTION

- R.F FLANGED ENDS TO ASME B16.5
- B.W. ENDS TO ASME B16.25
- R.T.J FLANGED ENDS TO ASME B16.5
- SIZE 26" AND LARGER, FLANGED ENDS ACCORDING TO ASME B16.47 SER.A OR SER.B
- CONSULT US FOR LARGER SIZE

STANDARD MATERIAL SPECIFICATIONS

NO.	PART NAME	MATERIAL
1	BODY	A216-WCB
2	CAP	A216-WCB
3	LOWER COVER	A216-WCB
4	BALL	A351-CF8M
5	SEAT RETAINER	A351-CF8M
6	STEM	A276-316
7	LOWER STEM	A276-316
8	LANTERN RING	A276-316
10	CAP BOLT	A193-B7
11	NUT	A194-2H
12	LOWER COVER BOLT	A193-B7
13	PAD BOLT	A193-B7
14	SEAT RING	RTFE
15	PACKING	GRAPHITE
16	CAP GASKET	GRAPHITE
17	LOWER COVER GASKET	GRAPHITE
18	FIRE SAFE SEAL	GRAPHITE
19	THRUST BEARING	DU-BUSH
21	STEM BEARING	DU-BUSH
22	LOWER STEM BEARING	DU-BUSH
23	PAD BEARING	DU-BUSH
24	O-RING	VITON
31	SPRING	INCONEL-X750
32	PIN	316SS
33	GEAR BOX	DUCTILE
34	STEM SEALANT FITTING	316SS
35	DRAIN PLUG	316SS

DIMENSION AND WEIGHT

CLASS 150

UNIT : mm

SIZE	B	10	12	14	16	18	20	24	30
Ød		254	305	337	387	438	489	591	737
Ød1		203	254	254	305	337	387	489	591
L	RF	533	610	686	762	864	914	1067	1295
	RTJ	546	622	698	775	876	927	1079	-
	BW	559	635	762	838	914	991	1143	1397
H		325	356	356	415	485	550	640	745
W1		400	500	500	500	560	560	710	800
APPROX(Kg)/ WEIGHT(RF)		230	282	478	583	889	954	1652	4450

CLASS 300

UNIT : mm

SIZE	B	10	12	14	16	18	20	24	30
Ød		254	305	337	387	438	489	591	737
Ød1		203	254	254	305	337	387	489	591
L	RF	568	648	762	838	914	991	1143	1397
	RTJ	584	664	778	854	930	1010	1165	1422
	BW	559	635	762	838	914	991	1143	1397
H		325	362	362	420	490	555	645	745
W1		400	500	500	500	560	560	710	800
APPROX(Kg)/ WEIGHT(RF)		280	312	521	623	1025	1180	1950	6100

CLASS 600

UNIT : mm

SIZE	B	10	12	14	16	18	20	24	30
Ød		254	305	337	387	438	489	591	737
Ød1		203	254	254	305	337	387	489	591
L	RF	787	838	889	991	1092	1194	1397	1651
	RTJ	791	841	892	994	1095	1200	1406	1664
	BW	787	838	889	991	1092	1194	1397	1651
H		335	425	425	475	540	610	710	815
W1		400	560	560	560	630	710	800	900
APPROX(Kg)/ WEIGHT(RF)		350	605	820	980	1805	2480	3800	5910

TRUNNION BALL, REDUCED BORE ASME CLASS 150#, 300#, 600#

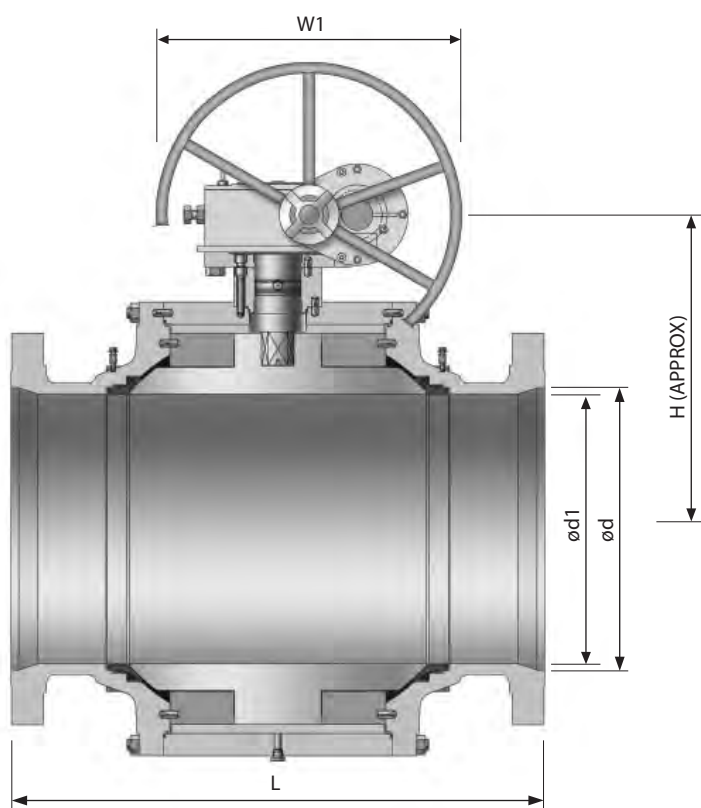

END CONNECTION

- R.F FLANGED ENDS TO ASME B16.5
- B.W. ENDS TO ASME B16.25
- R.T.J FLANGED ENDS TO ASME B16.5
- SIZE 26" AND LARGER, FLANGED ENDS ACCORDING TO ASME B16.47 SER.A OR SER.B
- CONSULT US FOR LARGER SIZE

STANDARD MATERIAL SPECIFICATIONS

NO.	PART NAME	MATERIAL
1	BODY	A216-WCB or A105
2	CAP	A216-WCB or A105
3	BALL	A315-CF8M
4	STEM	A276-316
5	SEAT RING	RTFE
6	PACKING	GRAPHITE
7	CAP GASKET	GRAPHITE
8	GLAND GASKET	GRAPHITE
9	FIRE SAFE SEAL	GRAPHITE
10	SEAT RETAINER	A351-CF8M
11	TRUNNION PLATE	A105+ENP
12	GLAND	AISI-1020
14	STEM BEARING	DU-BUSH
16	TRUNNION BEARING	DU-BUSH
17	PAD BEARING	DU-BUSH
18	THRUST BEARING	DU-BUSH
20	O-RING	VITON
25	CAP BOLT	A193-B7
26	NUT	A914-2H
27	GLAND BOLT	A193-B7
28	PAD BOLT	A193-B7
29	PIN	A276-316
33	SPRING	INCONEL-X750
34	GEAR BOX	DUCTILE
35	STEM SEALANT FITTING	316SS
36	DRAIN PLUG	316SS

DIMENSION AND WEIGHT

CLASS 150

UNIT : mm

SIZE	B	16	18	20	24	30	36
Ød		387	438	489	591	737	876
Ød1		305	337	387	489	591	737
L	RF	762	864	914	1067	1295	1524
	RTJ	775	876	927	1079	-	-
	BW	838	914	991	1143	1397	1727
H		415	435	503	553	585	778
W1		500	630	710	710	800	900
APPROX(Kg)/ WEIGHT(RF)		730	1025	1210	2100	3430	6450

CLASS 300

UNIT : mm

SIZE	B	16	18	20	24	30	36
Ød		387	438	489	591	737	876
Ød1		305	337	387	489	591	737
L	RF	838	914	991	1143	1397	1727
	RTJ	854	930	1010	1165	1422	1756
	BW	838	914	991	1143	1397	1727
H		420	440	510	560	590	785
W1		500	630	710	710	800	900
APPROX(Kg)/ WEIGHT(RF)		1010	1420	1729	2750	4630	8330

CLASS 600

UNIT : mm

SIZE	B	16	18	20	24	30	36
Ød		387	438	489	591	737	876
Ød1		305	337	387	489	591	737
L	RF	991	1092	1194	1397	1651	2083
	RTJ	994	1095	1200	1406	1664	2098
	BW	991	1092	1194	1397	1651	2083
H		425	445	518	575	605	815
W1		710	710	800	800	900	900
APPROX(Kg)/ WEIGHT(RF)		1360	1580	2170	3390	5910	10560

TRUNNION BALL, REDUCED BORE ASME CLASS 900#, 1500#

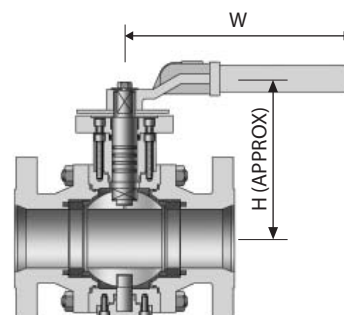
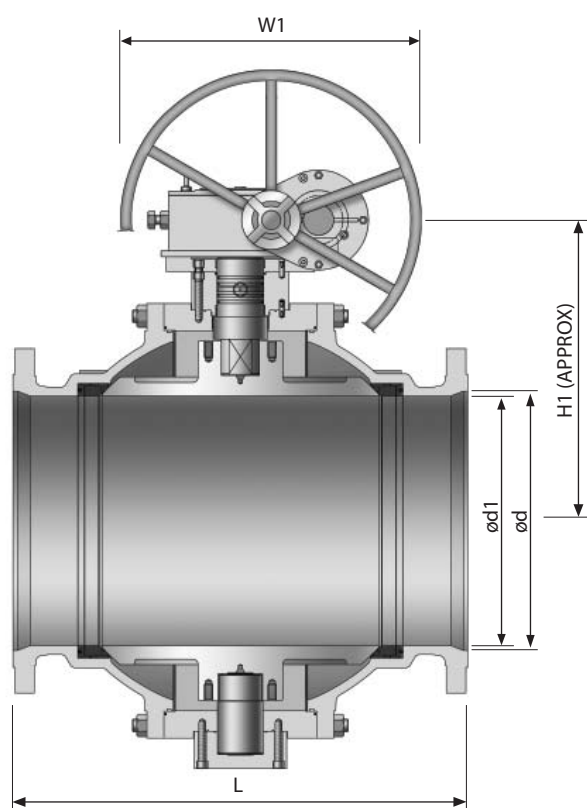

END CONNECTION

- R.F FLANGED ENDS TO ASME B16.5
- B.W. ENDS TO ASME B16.25
- R.T.J FLANGED ENDS TO ASME B16.5
- SIZE 26" AND LARGER, FLANGED ENDS ACCORDING TO ASME B16.47 SER.A OR SER.B
- CONSULT US FOR LARGER SIZE

STANDARD MATERIAL SPECIFICATIONS

NO.	PART NAME	MATERIAL
1	BODY	A215 WCB or A105
2	CAP	A216-WCB
3	BALL	A351-CF8M
4	STEM	A564-630
5	LOWER STEM	A564-630
6	SEAT POCKET	A351-CF8M
7	SEAT RETAINER	A351-CF8M
8	LOWER COVER	A105
9	GLAND	AISI-1020
11	SEAT RING	NYLON
12	PACKING	GRAPHITE
13	CAP GASKET	GRAPHITE
14	LOWER COVER GASKET	GRAPHITE
15	GLAND GASKET	GRAPHITE
16	SEAT POCKET SEAL	GRAPHITE
17	STEM BEARING	DU-BUSH
19	PAD BEARING	DU-BUSH
20	LOWER STEM BEARING	DU-BUSH
21	THRUST BEARING	DU-BUSH / PTFE
23	O-RING	VITON
28	CAP BOLT	A193-B7
29	NUT	A914-2H
30	LOWER COVER BOLT	A193-B7
31	GLAND BOLT	A193-B7
32	PAD BOLT	A193-B7
33	PIN	A276-316
35	SPRING	INCONEL-X750
36	GEAR BOX	DUCTILE

DIMENSION AND WEIGHT

CLASS 900

UNIT : mm

SIZE	B	2	3	4	6	8	10	12
Ød		50	76	100	152	203	254	305
Ød1		38	50	76	100	152	203	254
L	RF	368	381	457	610	737	838	965
	RTJ	371	384	460	613	740	841	968
	BW	368	381	457	610	737	838	965
H		195	205	235	270	-	-	-
H1		148	155	178	264	325	355	450
W		300	300	400	500	-	-	-
W1		300	300	300	300	400	630	630
APPROX(Kg)/ WEIGHT(RF)		45.0	58.0	105.0	230.0	470.0	530.0	1200.0

CLASS 1500

UNIT : mm

SIZE	B	2	3	4	6	8	10	12
Ød		50	76	100	152	203	254	305
Ød1		38	50	76	100	152	203	254
L	RF	368	470	546	705	832	991	1130
	RTJ	371	473	549	711	841	1000	1146
	BW	368	470	546	705	832	991	1130
H		195	205	240	275	-	-	-
H1		148	160	183	270	350	410	465
W		300	300	400	500	-	-	-
W1		300	300	300	300	400	630	630
APPROX(Kg)/ WEIGHT(RF)		45.0	75.0	130.0	301.0	615.0	1085.0	1850.0

TRUNNION BALL, REDUCED BORE ASME CLASS 900#, 1500#

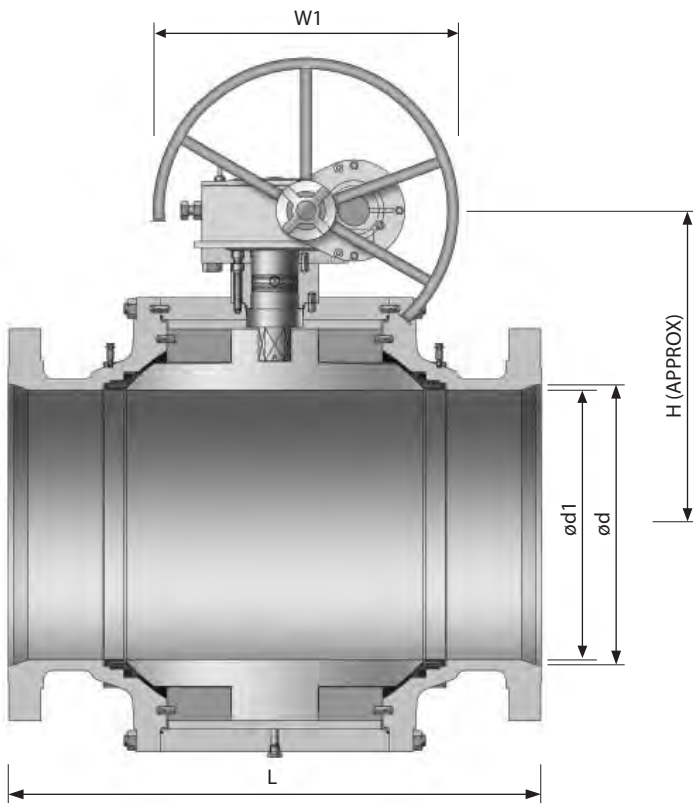

END CONNECTION

- R.F FLANGED ENDS TO ASME B16.5
- B.W. ENDS TO ASME B16.25
- R.T.J FLANGED ENDS TO ASME B16.5
- SIZE 26" AND LARGER, FLANGED ENDS ACCORDING TO ASME B16.47 SER.A OR SER.B
- CONSULT US FOR LARGER SIZE

STANDARD MATERIAL SPECIFICATIONS

NO.	PART NAME	MATERIAL
1	BODY	A215 WCB or A105
2	CAP	A215 WCB or A105
3	BALL	A351-CF8M
4	STEM	A276-316
5	SEAT RING	RTFE
6	PACKING	GRAPHITE
7	CAP GASKET	GRAPHITE
8	GLAND GASKET	GRAPHITE
9	FIRE SAFE SEAL	GRAPHITE
10	SEAT RETAINER	A351-CF8M
11	TRUNNION PLATE	A105+ENP
12	GLAND	AISI-1020
14	STEM BEARING	DU-BUSH
16	TRUNNION BEARING	DU-BUSH
17	PAD BEARING	DU-BUSH
18	THRUST BEARING	DU-BUSH
20	O-RING	VITON
25	CAP BOLT	A193-B7
26	NUT	A914-2H
27	GLAND BOLT	A193-B7
28	PAD BOLT	A193-B7
29	PIN	A276-316
33	SPRING	INCONEL-X750
34	GEAR BOX	DUCTILE
35	STEM SEALANT FITTING	316SS
36	DRAIN PLUG	316SS

DIMENSION AND WEIGHT

CLASS 900

UNIT : mm

SIZE	B	8	10	12	14	16	18	20	24
Ød		203	254	305	324	375	425	473	571
Ød1		152	203	254	305	305	324	375	473
L	RF	737	838	965	1029	1130	1219	1321	1549
	RTJ	740	841	968	1038	1140	1232	1333	1568
	BW	737	838	965	1029	1130	1219	1321	1549
H		375	396	485	531	531	600	620	750
W1		630	630	710	800	800	900	900	1000
APPROX(Kg)/ WEIGHT(RF)		470	530	1200	1695	1790	2240	2970	5580

CLASS 1500

UNIT : mm

SIZE	B	8	10	12	14	16	18	20	24
Ød		194	241	289	317	362	407	457	534
Ød1		146	194	241	289	289	317	362	457
L	RF	832	991	1130	1257	1384	1537	1664	2043
	RTJ	841	1000	1146	1276	1406	1559	1686	2071
	BW	832	991	1130	1257	1384	1537	1664	2043
H		320	410	495	565	565	605	625	760
W1		630	630	710	800	800	900	900	1000
APPROX(Kg)/ WEIGHT(RF)		615	1085	1850	2620	2890	5348	6950	11520

MEMO

Fully Integrated, Yet Flexible
PKvalve

FORGED STEEL VALVES

- GATE VALVES***
- GLOBE VALVES***
- LIFT CHECK VALVES***
- SWING CHECK VALVES***



FORGED STEEL VALVES

GATE VALVES

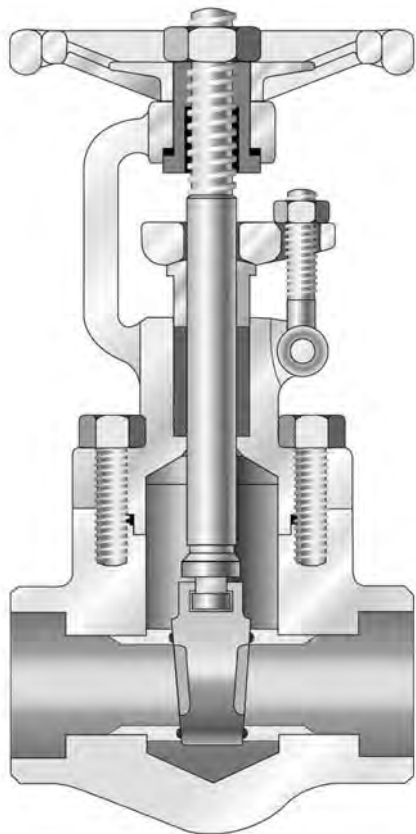

DESCRIPTION

serves as efficient stop valves with flow in either direction. They are commonly used where a minimum of pressure drop is important because they offer practically no resistance to flow when fully open. Throttling is not conducive to accurate and consistent flow control. Also the valves may be damaged by the high velocity across the seats. They function best fully open or fully closed.

CLASS

API 800, 1500
ANSI 150, 300, 600, 900, 1500, 2500

SIZE

3/8", 1/2", 3/4", 1", 1 1/4", 1 1/2", 2"

MATERIAL

ASTM A105, A182-F5, A182-F9, A182-F11,
A182-F22, A182-F304, A182-F316, A182-F304L,
A182-F316L, A182-F321, A182-F347, A182-F51,
A182-F91, A350-LF2
Other Materials also Available on Application

END CONNECTION

Socket welding, threaded
Butt welding, flanged

FEATURE

Bolted bonnet or welded bonnet
Outside screw & yoke
Solid wedge disc
Renewable seat

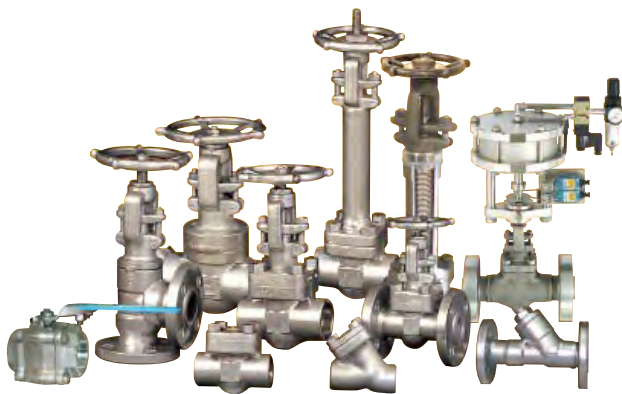

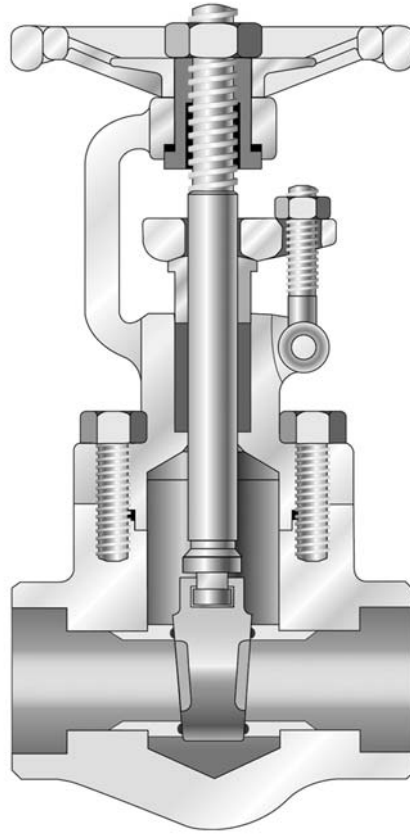

STANDARD MATERIAL SPECIFICATIONS

PART No.	PART NAME	Q'TY	A105	ASTM SPECIFICATIONS(SPECS-GRADES/TYPES)									
				A182				A182					
				F304	F304L	F316	F316L	F1	F5	F9	F11	F22	
1	Body	1	A105	A182-F304	A182-F304L	A182-F316	A182-F316L	A182-F1	A182-F5	A182-F9	A182-F11	A182-F22	
2	Bonnet	1	A105	A182-F304	A182-F304L	A182-F316	A182-F316L	A182-F1	A182-F5	A182-F9	A182-F11	A182-F22	
4	Stem	1	A276-410	A276-304	A276-316		A276-410						
5	Disc	1	A217-CA15	A351-CF8	A351-CF8M		A217-CA15						
7	Seat Ring	2	A276-410+STL	A276-304+STL'	A276-316+STL'		A276-410+STL'						
12	Bonnet Bolt	4	A193-B7	A193-B8				A193+B7					
13	Gasket	1	SS304+Graphite		SS316+Graphite			SS304+Graphite					
14	Gland	1								A276-304			
15	Gland Packing	1set								Graphite			
16	Gland Flange	1	A105	A182 F304				A105					
17	Gland Bolt	2							A193-B8				
18	Gland Bolt Nut	2	A194-2H	A194-8				A194-2H					
19	Gland Bolt Pin	2							A276-304				
20	Sleeve	1							A276-410				
21	Sleeve Washer	2							A276-410				
22	Handwheel	1							A197				
23	Nameplate	1							Aluminum				
24	Handwheel Nut	1							SS400+Zn PLATE				

(1)A105 also Available with 0.25% Maximum Carbon.

Other Materials also Available on Application.

CLASS 600 & 800

BOLTED BONNET OS & Y

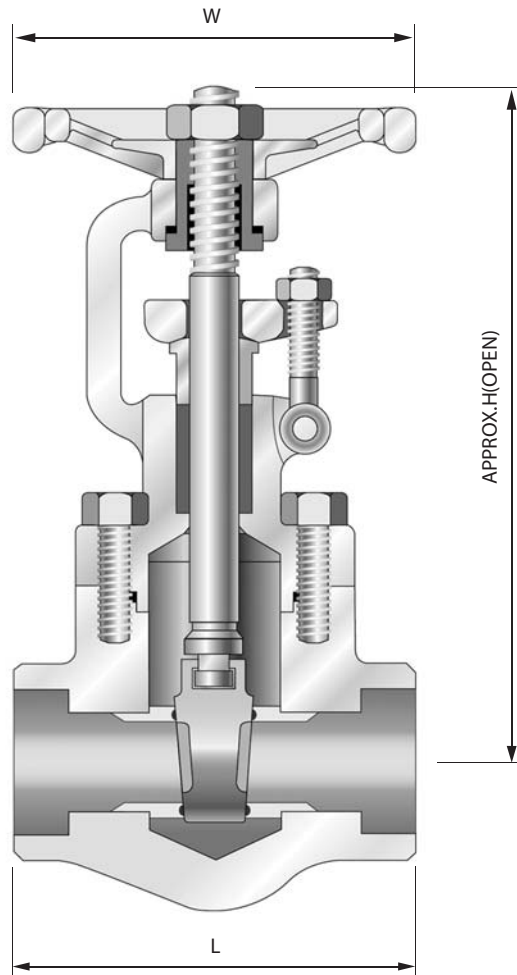

Bolted Bonnet

DIMENSION AND WEIGHT

CLASS	PORT	VALVE SIZE	CENTER TO TOP, OPEN	END TO END	HAND WHEEL DIAMETER	PORT DIAMETER	APPROX. WEIGHT	
			H	L	W	d	kg	lb
			DN	mm	mm	mm	mm	
600 & 800	REDUCED	10	133	73	90	10	1.5	3.3
		15	133	73	90	10	1.4	3.1
		20	149	87	90	13	1.9	4.2
		25	178	96	105	19	2.7	6.0
		32	210	121	125	25	4.8	10.6
		40	222	141	125	30	5.4	11.9
		50	257	161	150	37	8.9	19.6
	FULL	10	133	73	90	10	1.4	3.1
		15	149	87	90	13	1.9	4.2
		20	178	96	105	19	2.7	6.0
		25	210	121	125	25	4.8	10.6
		32	222	141	125	30	5.4	11.9
		40	257	161	150	37	8.9	19.6
		50	292	170	165	43	11.2	24.7

CLASS 900 & 1500

WELDED BONNET

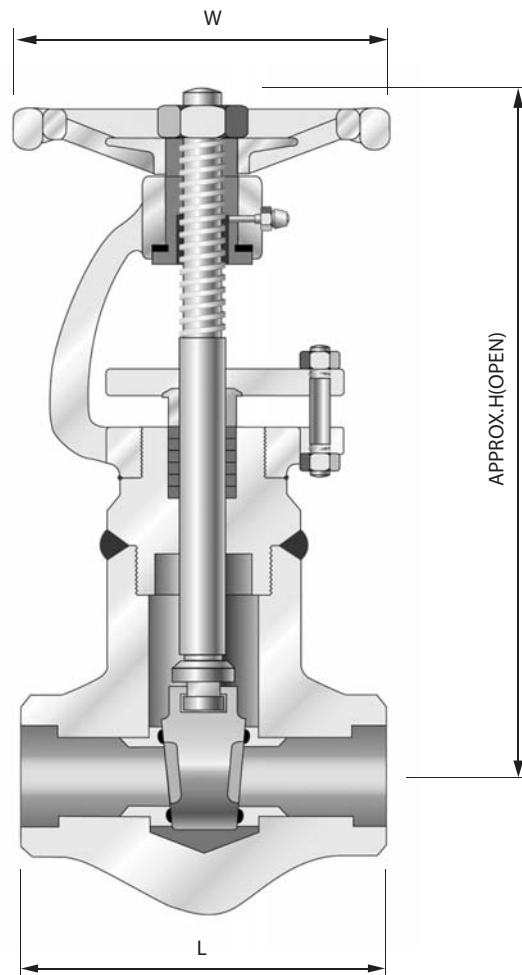

Seal Welded Bonnet

DIMENSION AND WEIGHT

CLASS	PORT	VALVE SIZE	CENTER TO TOP, OPEN	END TO END	HAND WHEEL DIAMETER	PORT DIAMETER	APPROX. WEIGHT	
			H	L	W	d	kg	lb
			mm	mm	mm	mm		
900 & 1500	FULL	10	233	96	150	10	2.3	5.1
		15	233	96	150	13	2.3	5.1
		20	245	121	150	19	4.8	10.6
		25	300	141	200	25	5.4	11.9
		32	331	161	200	30	8.9	19.6
		40	355	172	200	37	15.2	34.5
		50	439	200	245	37	25.4	56.0

CLASS 2500

WELDED BONNET

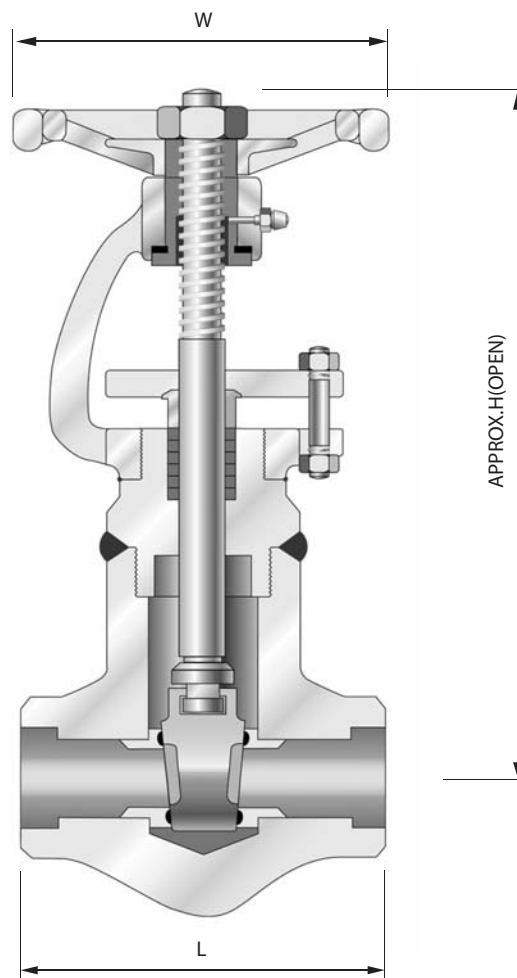

Seal Welded Bonnet

DIMENSION AND WEIGHT

CLASS	PORT	VALVE SIZE	CENTER TO TOP, OPEN	END TO END	HAND WHEEL DIAMETER	PORT DIAMETER	APPROX. WEIGHT	
			H	L	W	d	kg	lb
			mm	mm	mm	mm		
2500	FULL	15	245	121	150	11	2.9	6.39
		20	300	141	200	14	4.8	10.5
		25	331	161	200	20	5.4	11.9
		32	335	172	200	26	8.9	19.6
		40	439	200	245	29	26.8	59.1
		50	481	220	315	38	33.4	73.6

GLOBE VALVES

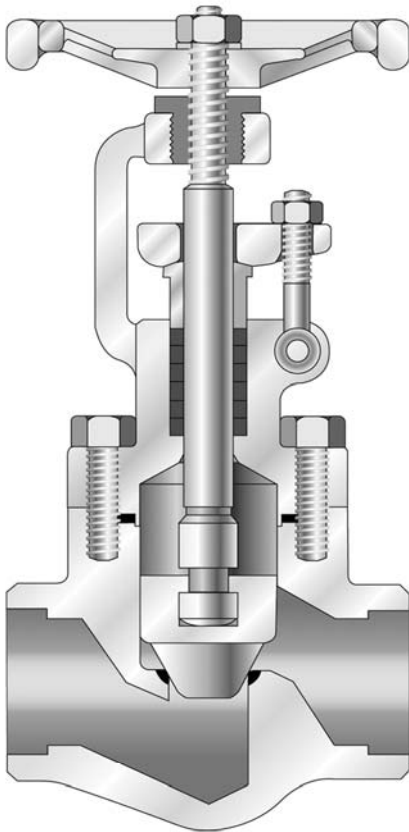

DESCRIPTION

Globe Valve is ideal for throttling service. Their flow characteristics permit accurate and repeatable flow control. However, caution must be exercised to avoid extremely close throttling when pressure drop exceeds 20%. This creates excessive noise, vibration, and possibly damage to valves and piping.

CLASS

API 800, 1500

ANSI 150, 300, 600, 900, 2500, 4500

SIZE

3/8", 1/2", 3/4", 1", 1 1/4", 1 1/2", 2"

MATERIAL

ASTM A105, A182-F5, A182-F9, A182-F11, A182-F22, A182-F304, A182-F316, A182-F304L, A182-F316L, A182-F321, A182-F347, A182-F51, A182-F91, A350-LF2

Other Materials also Available on Application

END CONNECTION

Socket welding, threaded

Butt welding, flanged

FEATURE

Bolted bonnet or welded bonnet

Outside screw & yoke

Plug disc

Integral seat

GLOBE VALVES

BOLTED BONNET OS & Y

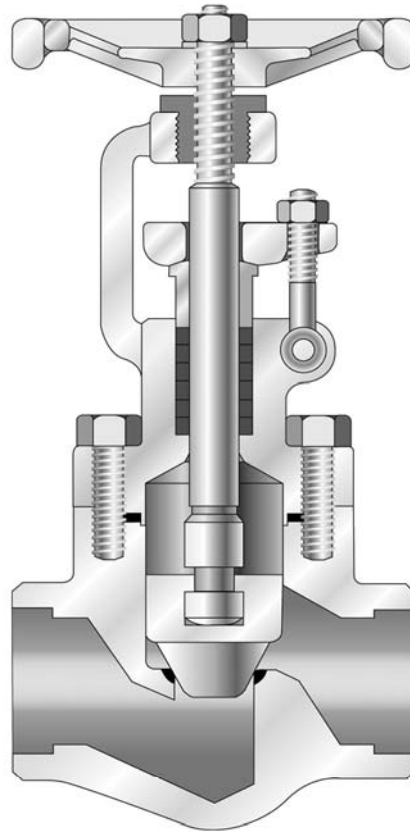

Bolted Bonnet

STANDARD MATERIAL SPECIFICATIONS

PART No.	PART NAME	Q'TY	A105	ASTM SPECIFICATIONS(SPECS-GRADES/TYPES)								
				A182				A182				
				F304	F304L	F316	F316L	F1	F5	F9	F11	F22
1	Body	1	A105	A182-F304	A182-F304L	A182-F316	A182-F316L	A182-F1	A182-F5	A182-F9	A182-F11	A182-F22
2	Bonnet	1	A105	A182-F304	A182-F304L	A182-F316	A182-F316L	A182-F1	A182-F5	A182-F9	A182-F11	A182-F22
4	Stem	1	A276-410	A276-304	A276-316		A276-410					
5	Disc	1	A217-CA15	A351-CF8	A351-CF8M		A217-CA15					
12	Bonnet Bolt	4	A193-B7	A193-B8		A193+B7						
13	Gasket	1	SS304+Graphite		SS316+Graphite		SS304+Graphite					
14	Gland	1	A276-304				Graphite					
15	Gland Packing	1set	Graphite				Graphite					
16	Gland Flange	1	A105	A182+F304				A105				
17	Gland Bolt	2	A193-B8				A193-B8					
18	Gland Bolt Nut	2	A194-2H	A194-8				A194-2H				
19	Gland Bolt Pin	2	A276-304				A276-304					
20	Sleeve	1	A276-410				A276-410					
22	Handwheel	1	A197				A197					
23	Nameplate	1	Aluminum				Aluminum					
24	Handwheel Washer	1	A108-1020				A108-1020					
25	Handwheel Net	1	A307-B				A307-B					

CLASS 600 & 800

BOLTED BONNET OS & Y

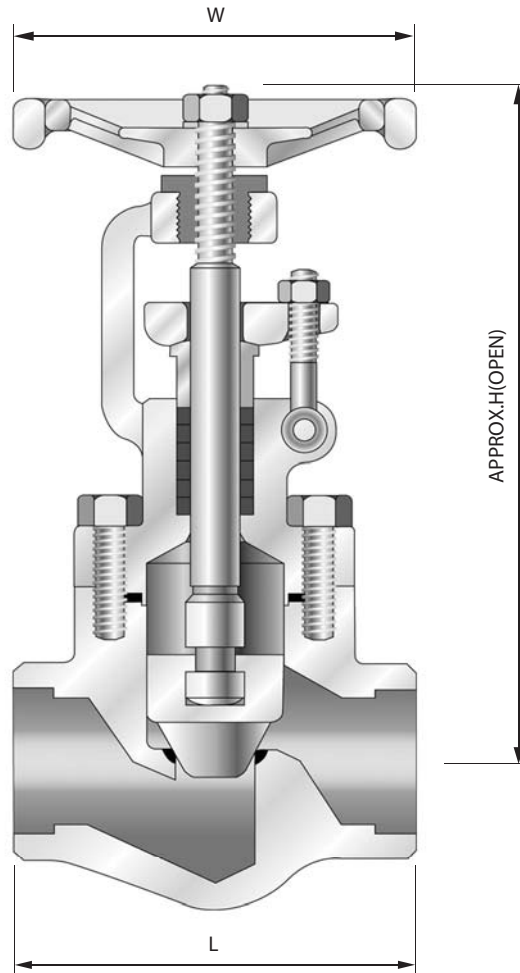

Bolted Bonnet

DIMENSION AND WEIGHT

CLASS	PORT	VALVE SIZE	CENTER TO TOP, OPEN	END TO END	HAND WHEEL DIAMETER	PORT DIAMETER	APPROX. WEIGHT	
			H	L	W	d	kg	lb
			DN	mm	mm	mm	mm	
600 & 800	REDUCED	10	134	73	90	8	1.5	3.3
		15	134	73	90	11	1.4	3.1
		20	146	87	90	13	1.9	4.2
		25	177	96	105	19	2.7	6.0
		32	205	121	125	25	4.9	10.8
		40	215	141	125	28	5.8	12.8
		50	248	161	150	36	9.3	20.5
	FULL	10	146	73	90	11	1.4	3.1
		15	146	87	90	13	1.9	4.2
		20	177	96	105	19	2.7	6.0
		25	205	121	125	22	4.9	10.8
		32	215	141	125	28	5.8	12.8
		40	248	161	150	32	9.3	20.5
		50	276	220	165	42	11.2	24.7

CLASS 900 & 1500

BOLTED BONNET OS & Y

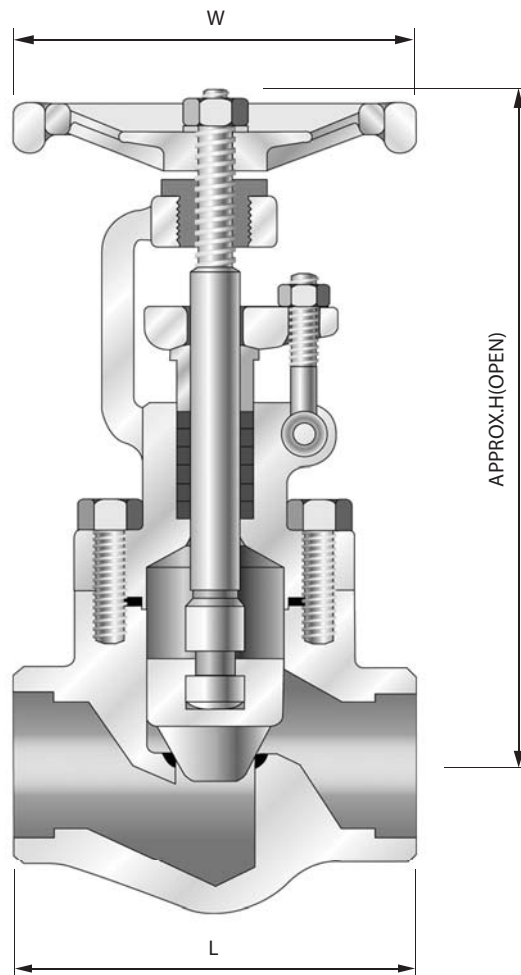

Bolted Bonnet

DIMENSION AND WEIGHT

CLASS	PORT	VALVE SIZE	CENTER TO TOP, OPEN	END TO END	HAND WHEEL DIAMETER	PORT DIAMETER	APPROX. WEIGHT	
			H	L	W	d	kg	lb
		DN	mm	mm	mm	mm		
900 & 1500	REDUCED	10	177	87	105	8	1.9	4.2
		15	177	96	105	11	1.9	4.2
		20	177	96	105	13	2.7	6
		25	205	121	125	19	4.9	10.8
		32	215	141	125	25	5.8	12.8
		40	248	161	150	28	9.3	20.5
		50	276	172	165	36	20.4	44.9

CLASS 1500 & 2500

WELDED BONNET OS & Y

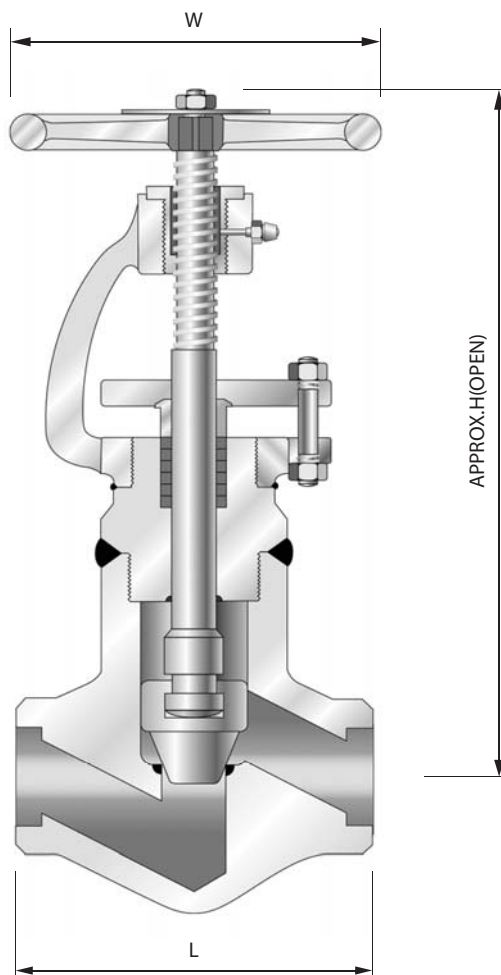

Seal Welded Bonnet

DIMENSION AND WEIGHT

CLASS	PORT	VALVE SIZE	CENTER TO TOP, OPEN	END TO END	HAND WHEEL DIAMETER	PORT DIAMETER	APPROX. WEIGHT	
			H	L	W	d	kg	lb
			DN	mm	mm	mm	mm	
1500	FULL	15	233	96	150	13	6.75	14.88
		20	245	121	150	18	8.9	19.62
		25	299	141	200	19	16.5	36.37
		32	325	161	200	25	18.4	40.56
		40	347	172	200	32	26.4	58.2
		50	433	200	245	36	33.5	73.9
2500	FULL	15	245	121	150	11	18.4	40.56
		20	299	141	200	14	18.3	40.34
		25	325	161	200	19	18.3	40.34
		32	347	172	200	25	26.4	58.4
		40	433	200	245	28	26.4	58.2
		50	486	220	315	38	33.5	73.9

LIFT CHECK VALVES

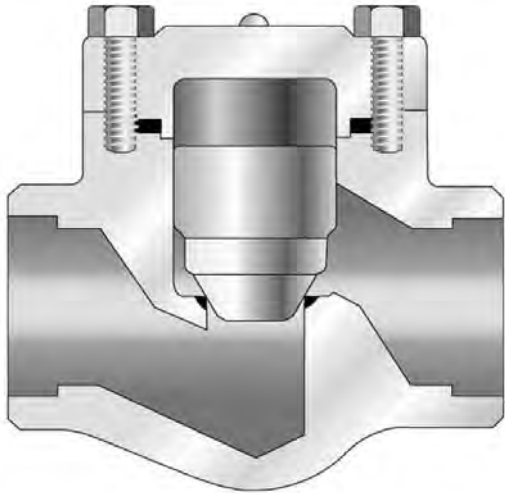

LIFT CHECK

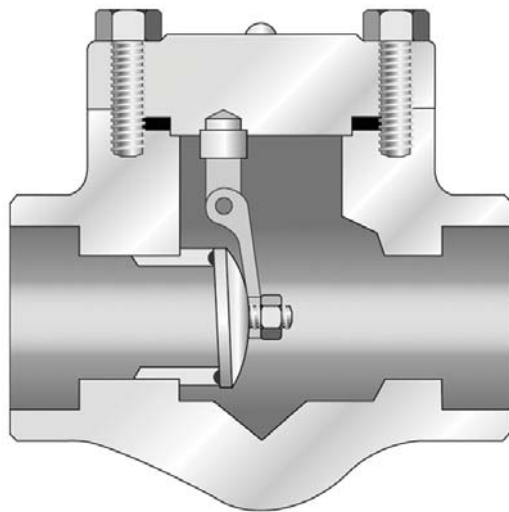

SWING CHECK

LIFT CHECK VALVES DESCRIPTION

have an advantage over most other types of check valves in that they need only a relatively short lift to obtain full valve opening. The lift check valve uses a free-moving closure element that is placed above the seat. It prevents backflow and maintains pressure. The lift check valve is recommended to install in horizontal piping lines because the disc is pushed up by the flow until the flow reverses when gravity and down stream pressure close the closure element against the seat.

CLASS

API 800, 1500

ANSI 150, 300, 600, 900, 1500, 2500, 4500

SIZE

3/8", 1/2", 3/4", 1", 1 1/4", 1 1/2", 2"

MATERIAL

ASTM A105, A182-F5, A182-F9, A182-F11, A182-F22, A182-F304, A182-F316, A182-F304L, A182-F316L, A350-LF2

END CONNECTION

SOCKET WELDING, THREADED

BUTT WELDING, FLANGED

FEATURE

BOLTED COVER OR WELDED COVER

INTEGRAL SEAT

SWING CHECK VALVES DESCRIPTION

prevent reversal of flow through pipe lines. The swing check valve uses a hinged door to open during flow and to close against a pressure reversal. Most dong-kang swing check valves can be installed in horizontal or vertical upward flow piping. They offer low resistance to flow and are particularly suited to low velocity service

CLASS

API 800, 1500

ANSI 150, 300, 600, 900, 1500

SIZE

3/8", 1/2", 3/4", 1", 1 1/4", 1 1/2", 2"

MATERIAL

ASTM A105, A182-F5, A182-F9, A182-F11, A182-F22, A182-F304, A182-F316, A182-F304L, A182-F316L, A182-F321, A182-F347, A182-F51, A182-F91, A350-LF2

Other Materials also Available on Application

END CONNECTION

Socket welding, threaded

Butt welding, flanged

FEATURE

Bolted cover or welded cover

Renewable seat

LIFT CHECK VALVES

BOLTED COVER

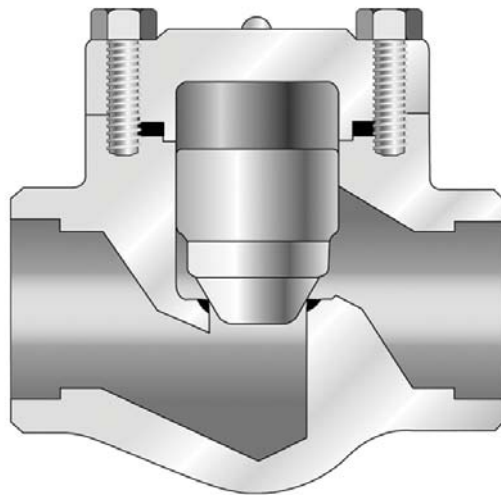

LIFT CHECK

STANDARD MATERIAL SPECIFICATIONS

NO.	PART NAME	Q'TY	MATERIAL-ASTM				
			A105	F304	F304L	F316	F316L
1	Body	1	A105	A182-F304	A182-F304L	A182-F316	A182-F316L
3	Cover	1	A105	A182-F304	A182-F304L	A182-F316	A182-F316L
5	Disc	1	A276-410	A276-304	A276-316		
12	Cover Bolt	4	A193-B7	A193-B8			
13	Gasket	1	SS304+Graphite			SS316+Graphite	
23	Nameplate	1	Aluminum				

CLASS 600 & 1500

BOLTED COVER

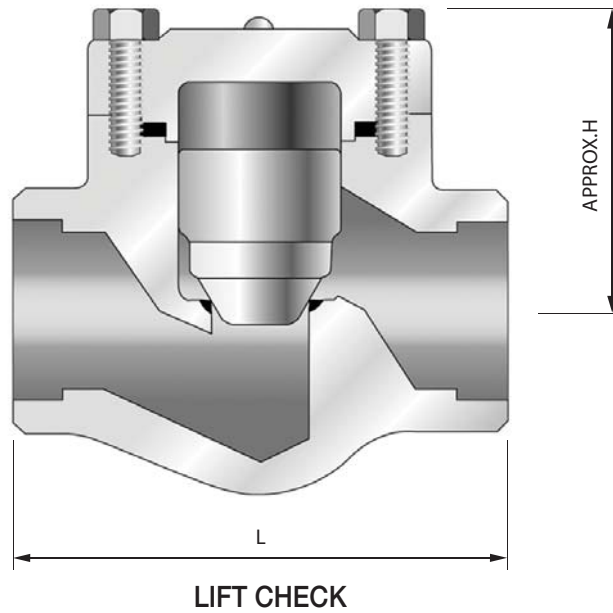

DIMENSIONS & WEIGHTS

CLASS	PORT	VALVE SIZE	CENTER TO TOP, OPEN	END TO END	PORT DIAMETER	APPROX. WEIGHT	
			H	L	d	kg	lb
			DN	mm	mm	mm	
600 & 800	REDUCED	10	51	73	8	1.3	2.9
		15	51	73	11	1.2	2.6
		20	55	87	13	1.3	2.9
		25	65	96	19	2.1	4.6
		32	76	121	25	4.0	8.8
		40	84	141	28	4.7	10.4
		50	101	161	36	7.1	15.6
	FULL	10	51	73	10	1.3	2.9
		15	55	87	13	1.3	2.9
		20	65	96	19	2.1	4.6
		25	76	121	22	4.0	8.8
		32	84	141	28	4.7	10.4
		40	101	161	32	7.1	15.6
		50	116	220	42	10.7	23.5
1500	REDUCED	10	65	87	8	1.2	2.6
		15	65	96	11	1.2	2.6
		20	65	96	13	2.1	4.6
		25	76	121	19	4.0	8.8
		32	84	141	25	4.7	10.4
		40	101	161	28	7.1	15.6
		50	116	172	36	10.5	23.1

CLASS 1500 & 2500

WELDED COVER

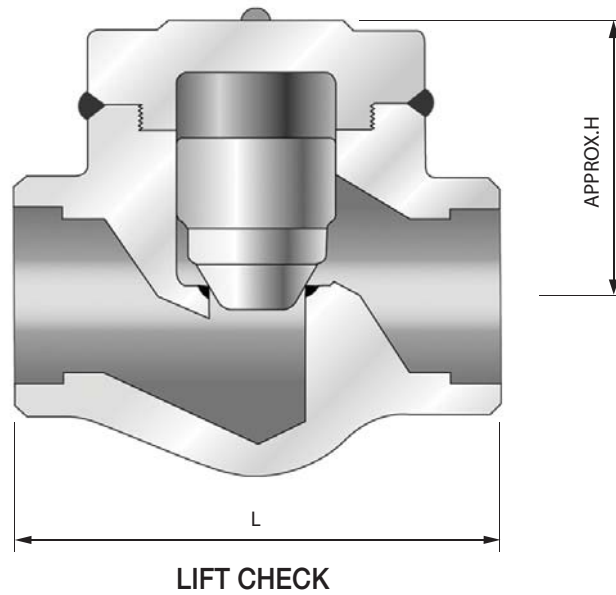

DIMENSIONS & WEIGHTS

CLASS	PORT	VALVE SIZE	CENTER TO TOP, OPEN	END TO END	PORT DIAMETER	APPROX. WEIGHT	
			H	L	d	kg	lb
		DN	mm	mm	mm		
1500	FULL	15	65	96	13	2.1	4.6
		20	73	121	18	4.0	8.8
		25	80	141	22	4.7	10.4
		32	100	161	28	7.1	15.6
		40	110	172	32	10.7	23.5
		50	140	200	35	12.5	27.5
2500	FULL	15	73	121	11	7.1	15.6
		20	80	141	14	7.1	15.6
		25	100	161	19	7.1	15.6
		32	110	172	25	10.7	23.5
		40	140	200	28	10.7	23.5
		50	160	220	38	12.5	27.5

SWING CHECK VALVES

BOLTED COVER

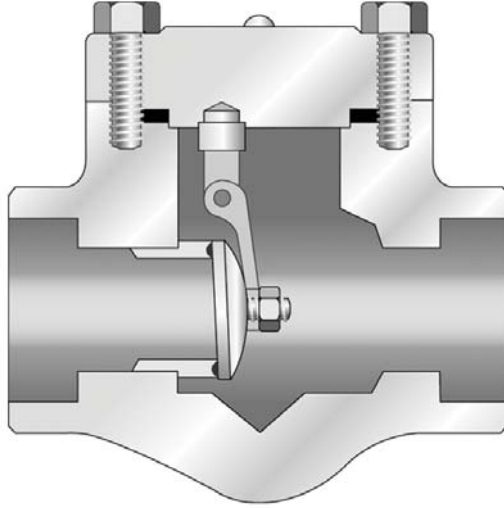

SWING CHECK

STANDARD MATERIAL SPECIFICATIONS

NO.	PART NAME	Q'TY	MATERIAL-ASTM				
			A105	F304	F304L	F316	F316L
1	Body	1	A105	A182-F304	A182-F304L	A182-F316	A182-F316L
3	Cover	1	A105	A182-F304	A182-F304L	A182-F316	A182-F316L
5	Disc	1	A276-410	A276-304		A276-316	
7	Seat Ring	1	A276-410	A276-304		A276-316	
8	Retaining Nut	1	A194-2H		A194-8		
9	Hinge	1				A351-CF8M	
10	Hinge Pin	1			A276-316		
11	Supporter	1				A276-316	
12	Cover Bolt	4	A193-B7		A193-B8		
13	Gasket	1		SS304+Graphite		SS316+Graphite	
23	Nameplate	1			Aluminum		

CLASS 800 & 1500

BOLTED COVER

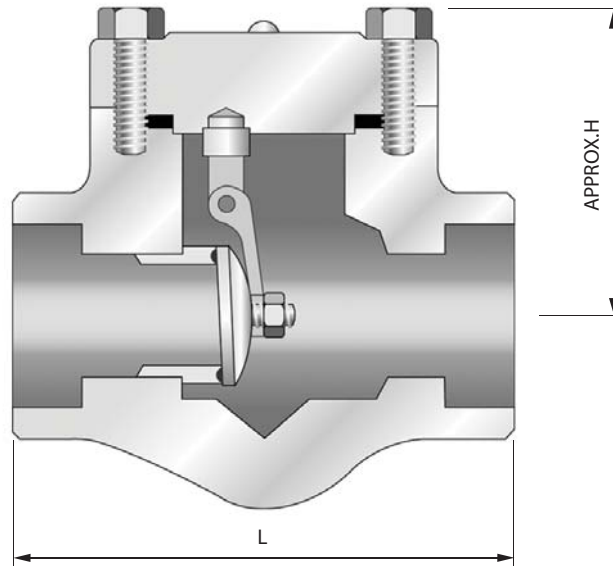

SWING CHECK

DIMENSIONS & WEIGHTS

CLASS	PORT	VALVE SIZE	CENTER TO TOP, OPEN	END TO END	PORT DIAMETER	APPROX. WEIGHT	
			H	L	d	kg	lb
		DN	mm	mm	mm		
800	REDUCED	10	51	73	10	1.1	2.42
		15	51	73	10	1.0	2.2
		20	55	87	13	1.4	3.0
		25	65	96	19	2.2	4.85
		32	76	121	25	4.0	8.8
		40	84	141	30	4.1	9.0
		50	101	161	37	6.0	13.2
	FULL	10	51	73	10	1.0	2.2
		15	55	87	13	1.4	3.0
		20	65	96	19	2.2	4.85
		25	76	121	25	4.0	8.8
		32	84	141	30	4.1	9.0
		40	101	161	37	6.0	13.2
		50	116	170	43	10.6	23.3
1500	REDUCED	10	65	87	10	1.4	3.2
		15	65	96	13	1.4	3.2
		20	65	96	13	2.2	5.0
		25	76	121	19	4.0	9.2
		32	84	141	25	4.1	9.4
		40	101	161	30	6.0	13.8
		50	116	172	37	9.3	20.5

MEMO

Fully Integrated, Yet Flexible
PKvalve

ACCESSORY



ACCESSORY



Chain wheel



Extended gear



Gearbox(General)



Gearbox(High load)



Limit switch



Locking device
(Chain & Padlock)



Locking device
(Gear)

Live-loading

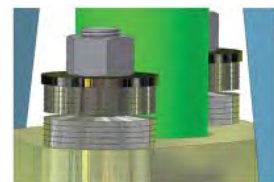
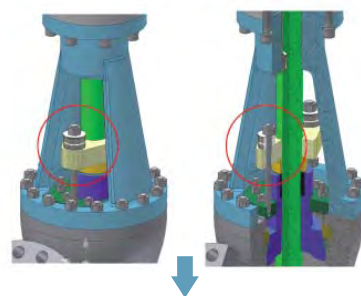

Live-loading Detail

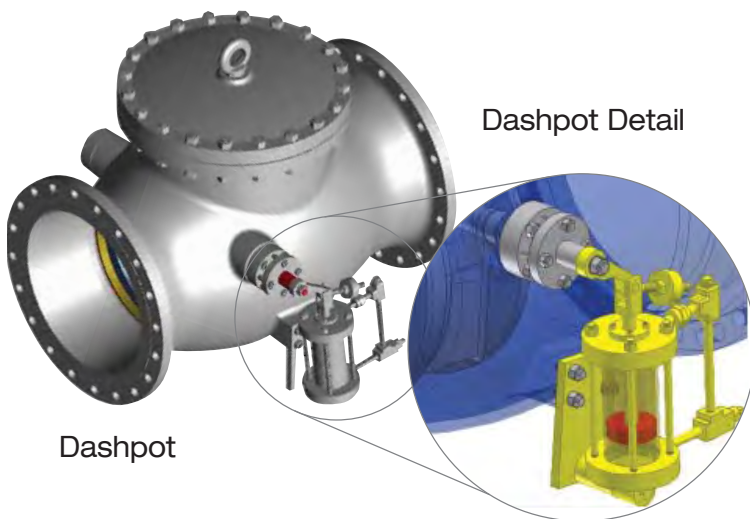

Dashpot Detail

Dashpot



Balance valve

By-pass valve

PK Valve Co.,Ltd.

Head Office & Factory

192-1, Shinchon-dong, Sungsan-gu, Changwon-City,
Korea 641-370

TEL 82-55-268-3777 FAX 82-55-286-0281

R&D Center

TEL 82-55-268-3780~9 FAX 82-55-286-3804

E-mail : mst@pkvalve.co.kr

Service Center

TEL 82-55-268-3872 FAX 82-55-286-0639

Seoul Office

158, Dujin Bldg. Samsung-dong Kangnam-gu, Seoul,
Korea 135-880

TEL 82-2-566-8461~2 FAX 82-2-566-2315

www.pkvalve.co.kr