

GWC ITALIA

Proven technology
for individual valve solutions
worldwide



**CAST STEEL VALVES
GATE, GLOBE & CHECK**

CSV-1005



GWC ITALIA

Worldwide Network

ITALY GROUP HEADQUARTERS, MANUFACTURING & SALES

GWC Italia S.p.A.
Via A. Grandi, 5
20056 Trezzo Sull'Adda
Milano, Italy
Phone: 39-02-86882941
Fax: 39-02-86882942
Email: sales@gwcitalia.com



**USA HEADQUARTERS
MANUFACTURING & SALES**
GWC Italia
7600 District Blvd.
Bakersfield, CA 93313 USA
ph: +1-661.834.1775
fax: +1-661.834.2072
Email: sales@gwcitalia-usa.com



SALES DUBAI
GWC Italia DMCC
1506, Platinum Tower
I-Cluster,
Jumeirah Lake Towers
Dubai UAE
ph: +971-44.539.358
Email: sales@gwcitalia.com



MANUFACTURING & SALES
GWC Valve Manufacturing
(Shanghai) Co., Ltd.
No 3300 Tianchen Road,
Qingpu, Shanghai 201708,
China
ph: +86-21.5979 8796
fax: +86-21.5979-8790
Email: sales@gwcitalia.com

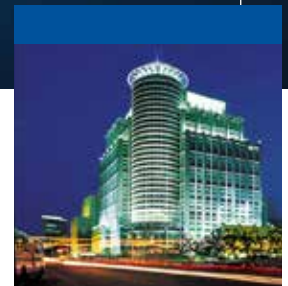

SALES CHINA
GWC Italia
5/F, China Life Tower, No.16
Chaowai Street
Chaoyang District
Beijing 100020, China
ph: +86 10 5877 1065
fax: +86 10 5877 1120
Email: sales@gwcitalia.com

GWC Italia SpA with its Headquarters in Milan, Italy fully designs, manufactures and markets valves with one of the most extensive Trunnion Mounted Ball Valve lines you will find in the Industry today. GWC Italia which was founded by an Italian Group & USA Entrepreneurial Management team has a history of building and managing successful valve Manufacturing companies over the past 40 years. GWC Italia Valves are used in major applications for Upstream, Downstream & Transportation Segments of the Oil & Gas Industry, E&P, Petrochemical, Chemical, Mining/Minerals, Power, Marine and Industrial markets.

GWC Italia's extensive line of valve and flow control products include:

- Trunnion Mounted Ball Valves (soft & metal seated)
 - Split Body
 - Top Entry
 - Welded Body
 - Subsea
 - Cryogenic & High Temperature
 - Compact Body (Twin Ball)
- Floating Ball Valves
- Pipeline Check Valves
- Gate, Globe and Check Valves including Cast & Forged
- Needle & Gauge Valves



Proven technology for individual valve solutions worldwide

CERTIFICATIONS & STANDARDS

American Standards

American Petroleum Institute

API-6D	Specification for Pipeline Valves
API-6D SS	Specification for Subsea Pipeline Valves
API-6A	Specification for Wellhead and Christmas Tree Equipment
API-6FA	Specification for Fire Test for Valves
API-607	Fire Test for Soft-Seated Quarter-Turn Valves
API-608	Metal Ball Valves - Flanged, Threaded, and Welding End
API-Q1	Specification for Quality Programs for the Petroleum, Petrochemical & Natural Gas

International Standards

ISO 9001:2008	Quality Management Systems
ISO 14001	Environmental Management
OHSAS 18001:2007	Occupational Health and Safety Management System
ISO/TS 29001	Petroleum, Petrochemical and Natural Gas Industries - Sector Specific Quality Management Systems
CE/PED	Pressure Equipment Directive
CU-TR	Technical Reglament Conformity Certificate TRCU
CRN	Canadian Registration Number
Z245.15.96	Pipeline Steel Valves
ATEX	European for explosive atmosphere
SIL3	Measurement of performance required for safety instrument function
ABS	American Bureau of Shipping



GATE VALVE STANDARD FEATURES

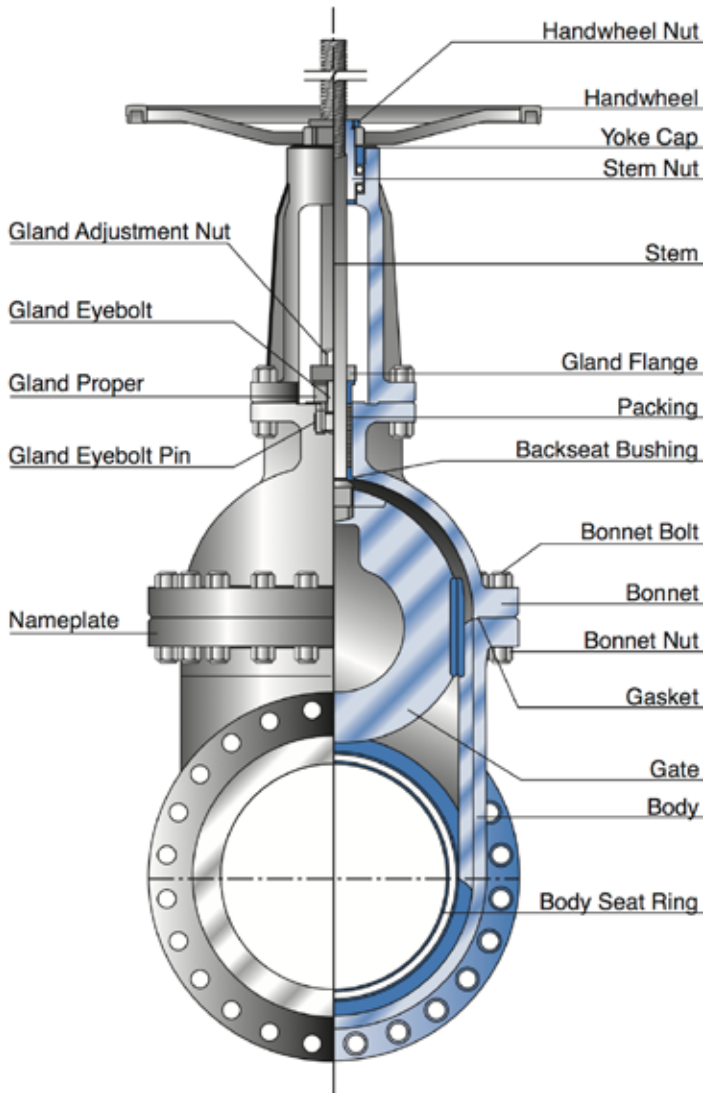

tight shut-off when fully closed, and remain relatively free of contamination buildup.

BODY & BONNET

The design of the body and bonnet is calculated to achieve the most regular distribution of stress in all directions, as well as the minimum turbulence and resistance to flow.

Valve bonnets are equipped with a backseat bushing. The yoke is integrally cast on Pressure Classes 150 and 300 up to 12” and up to 10” on Class 600 and higher ratings.

BODY-BONNET JOINT

Standard body-bonnet joints of gate valves are machined as follows:

PRESSURE CLASS	JOINT DESIGN
150	Flat Faced
300, 600	Male-and-Female
900* & over	Ring Type Joint

*Pressure Class 600 also available in Ring Type Joint.

GWC can supply any style of gasket required by customer.

GATE

All gates are fully guided to the seats. As standard our valves are supplied with a solid flexible gate that has a tapered H cross-section. The flexible wedge is cast or machined with a circumferential groove to allow the seating surfaces to move independently and adjust to movement of the body seats. This design is beneficial where line loads or thermal expansion of the system is likely to distort the seat face in the valve. This design of gate is ideally suited for steam or other high temperature services and is especially useful to prevent sticking where valves are closed when hot and opened when cold.

SEAT RING

Seat rings are designed to greatly reduce and/or prevent any turbulence and avoid damages due to the corrosion. The seat rings are forged or rolled in one piece, and then seal welded and overlaid, if required. After welding and all required heat treating, the seat ring faces are machined, thoroughly cleaned and inspected before leaving for assembly.

GWC Gate Valves are manufactured to the latest edition of API Standard 600 and tested to API Standard 598.

APPLICATION & FUNCTION

Gate valves are primarily used for stop valves fully opened or fully closed. They are not normally considered for throttling purposes, but more for slurries, viscous fluids, etc.

Gate valves are characterized by a traveling wedge, which is moved with the operation of the stem nut. The wedge travels perpendicular to the direction of the flow.

Gate valves usually have a minimum pressure drop when fully open, provide

GATE VALVE STANDARD FEATURES

STEM

The stem connection to the gate is a T-head design which is integral (without welding) with the stem. The accuracy in the dimensions and finishes assure a long life with a perfect tightness in the packing area, resulting in lower fugitive emissions.

The stem-to-gate connection is designed to prevent the turning or the disengagement of stem from the wedge while the valve is in service.

Through calculations and extreme testing, the strength of the stem-to-gate connection has proven to exceed the strength of the stem at the root of its operating thread.

STEM PACKING

The stem packing is designed and arranged to ensure a maximum seal along the stem during operation or while at position, thus allowing for a greater reduction in fugitive emissions. Our packings are NON-ASBESTOS types.

GWC can supply any style of packing required by our customer.

STUFFING BOX

The depth of the stuffing box allows for a sufficient amount of packing, which makes the stem seal. Our standard packing arrangement and stuffing box design meets <100 ppm fugitive emission requirements.

If specified in the purchase order, lantern rings and/or grease injectors can be furnished.

PACKING GLAND

The packing gland design is a two-piece self-aligning type. The packing gland has a spherical head that rides within the spherical joint of the gland flange. The packing gland has a shoulder, which restricts the complete entry into the stuffing box bore. This particular design assures a straight compression of the packing as the gland eyebolts are being equally adjusted, without injuring the stem.

STEM NUT

The stem nut arrangement and design allows for the removal of the handwheel without

allowing the stem and gate to drop into the closed position if the handwheel is removed while the valve is in the open position.

Ball bearings are provided in the stem nut arrangement of Class 150 valves from NPS 14", on Class 300 valves from NPS 12", on Class 600 valves from NPS 6", and on Classes 900-1500 valves from NPS 2".

HANDWHEELS

Handwheels are designed for easy operation and a comfortable grip. Our valves are also available with gearing, motor actuators or cylinder actuators for the more demanding services.

BOLTS AND NUTS

For normal service conditions, ASTM A194 Class 2H and ASTM A193 Grade B7 nuts and stud bolts are furnished. If specified for high temperature service conditions, ASTM A194 Class 4 and ASTM A193 Grade B16 nuts and stud bolts are furnished. Standard bolting furnished for our stainless steel valves consists of ASTM A194 Class 8 and ASTM A193 Grade B8 nuts and stud bolts.

GWC can supply any bolting as required by the customer.

END CONNECTIONS

Our standard production covers valves with:

- Flange ends with Raised Face (RF), Flat Face (FF) or Ring Type Joint (RTJ) that conform to B16.5.
- Butt-welding ends (BW) that conform to B16.25.
- All face-to-face/end-to-end dimensions conform to B16.10.
- Other special end connections are supplied according to customer's requirements.

ACCESSORIES

Accessories such as gear operators, actuators, bypasses, locking devices, chainwheels, extended stems and bonnets for cryogenic service and many others are available to meet the customers requirements.

GLOBE VALVE STANDARD FEATURES

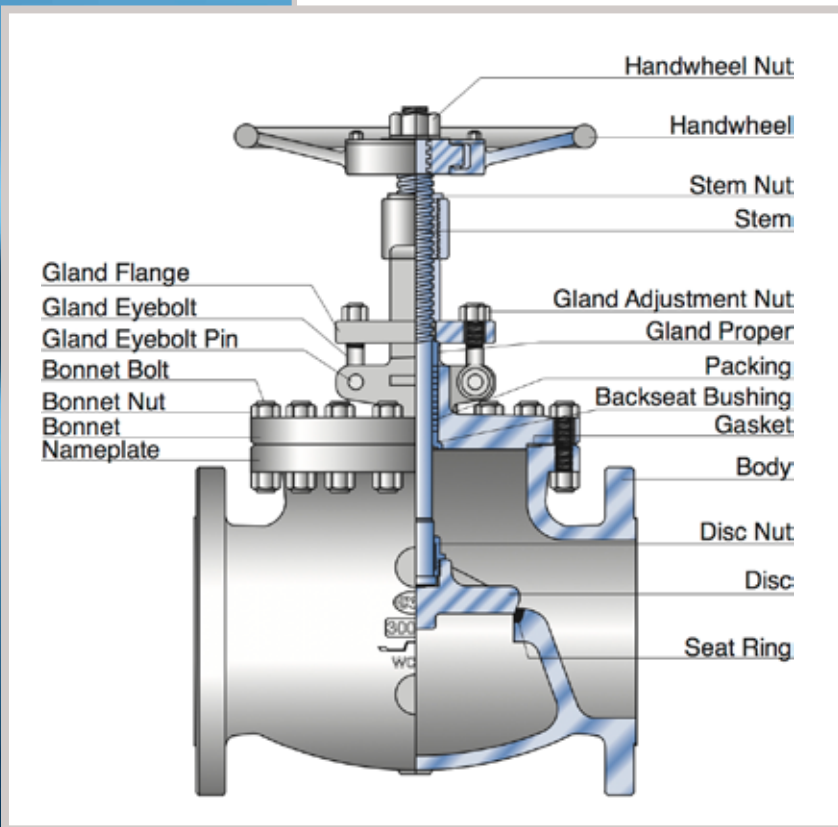

GWC Globe Valves are manufactured and modified to the latest edition of API Standard 600/ASME B16.34 and tested to API Standard 598.

APPLICATION & FUNCTION

Globe valves are primarily used as control valves where throttling or both throttling and shut-off are required. Globe valves can also be used for on-off service; however, because of the design, a pressure drop becomes inherent. This is generally confined to on-off applications where the valve is normally closed and pressure drop is not important when the valve is open. Normal applications will find the globe valve with the flow and pressure under the disc. GWC cast steel globe valves are commonly made in outside screw and yoke designs with full ports (including seat ring) and heavy-duty, conical plug type discs.

BODY & BONNET

The body is full ported and spherical in form. The design utilizes large radiuses which allow for the stresses, flow resistance and turbulence to be kept to a minimum.

Valve bonnets are equipped with a backseat bushing.

BODY-COVER JOINT

Standard body-cover joints of our globe valves are machined as follows:

PRESSURE CLASS	JOINT DESIGN
150, 300, 600	Male-and-Female
900* & over	Ring Type Joint

*Pressure Class 600 also available in Ring Joint Type

GWC can supply any style of gasket required by the customer.

DISC

The valve is normally supplied with the conical plug type disc. The disc rotates freely on the stem and incorporates a differential angle from that on the seat ring. This design provides the maximum assurance of shut off, is less likely to stick in the body seat, and is considered the simplest design for field repair.

The disc is held onto the stem utilizing the disc nut and a split-ring disc retainer on 2”-4” in pressure classes 150 and 300. Larger sizes as well as pressure classes 600 and higher utilize the disc nut and a button head design which is integral with the stem. Bottom guided discs are available.

SEAT RINGS

Seat rings are designed to greatly reduce and/or prevent any turbulence and avoid damages due to corrosion. The seat rings are forged or rolled in one piece and then seal welded and overlaid, if required. After welding and all required heat treating, the seat ring faces are machined, thoroughly cleaned and inspected before leaving for assembly.

STEM

As GWC’s standard, all stems are rotating and rising; however, a non-rotating design is available when specified by the customer. The accuracy in the dimensions and finishes assure a long life with a perfect tightness in the packing area, resulting in lower fugitive emissions. All of our stems are designed with integral backseat features which provide an ultimate seal during packing changes.

GLOBE VALVE STANDARD FEATURES

STUFFING BOX

The depth of the stuffing box allows for a sufficient amount of packing, which makes the stem seal. GWC's standard packing arrangement and stuffing box design meets <100 ppm fugitive emission requirements. If specified in the purchase order, lantern rings and/or grease injectors can be furnished.

STEM PACKING

The stem packing is designed and arranged to ensure a maximum seal along the stem during operation or while at position, thus allowing for a greater reduction in fugitive emissions. Our packings are of non-asbestos types.

GWC can supply any style of packing required by the customer.

PACKING GLAND

The packing gland design is a two-piece self-aligning type. The packing gland has a spherical head that rides within the spherical joint of the gland flange. The packing gland has a shoulder, which restricts the complete entry into the stuffing box bore. This particular design assures a straight compression of the packing as the gland eyebolts are being equally adjusted, without injuring the stem.

STEM NUT

The stem nuts on GWC's standard rising stem globe valves are threaded into the top of the yoke where they are secured with a tack weld.

OPERATION

Handwheels are designed with a comfortable grip for easy operation. As our standard, hammer-blow type handwheels are provided as listed in the next column:

PRESSURE CLASS

150
300 – 600
900 and over

JOINT DESIGN

8" and larger
6" and larger
4" and larger

Our valves are also available with gearing, motor actuators or cylinder actuators for the more demanding services.

BOLTS AND NUTS

For normal service conditions, ASTM A194 Class 2H and ASTM A193 Grade B7 nuts and stud bolts are furnished. If specified for high temperature service conditions, ASTM A194 Class 4 and ASTM A193 Grade B16 nuts and stud bolts are furnished. Standard bolting furnished for our stainless steel valves consists of ASTM A194 Class 8 and ASTM A193 Grade B8 nuts and stud bolts.

GWC can supply any bolting as requested by the customer.

END CONNECTIONS

Our standard production covers valves with:

- Flange ends with Raised Face (RF), Flat Face (FF) or Ring Type Joint (RTJ) that conform to B16.5.
- Butt-welding ends (BW) that conform to B16.25.
- All face-to-face/end-to-end dimensions conform to B16.10.
- Other special end connections are supplied according to customer's requirements.

ACCESSORIES

Accessories such as gear operators, actuators, bypasses, locking devices, chainwheels, extended stems and bonnets for cryogenic service and many others are available to meet the customers requirements.

SWING CHECK VALVE STANDARD FEATURES

GWC Swing Check Valves are manufactured and modified to the latest edition of API Standard 600/ASME B16.34 and tested to API Standard 598.

APPLICATION & FUNCTION

Swing check valves are designed to close quickly and automatically with positive shut off in either horizontal or vertical (flow up) pipe runs. Inherently, swing check valves have a low pressure drop and are best suitable for velocity applications.

Our closure design allows our swing check valve to close completely even and remain closed with no flow when installed in a horizontal pipe run.

BODY

The body is full ported and spherical in form. The design utilizes large radiuses which allow for the stresses, flow resistance and turbulence to be kept to a minimum. Bosses are provided for optional drains.

BODY-COVER JOINT

Standard body-cover joints of our swing check valves are machined as follows:

PRESSURE CLASS	JOINT DESIGN
150, 300, 600	Male-and-Female
900* & over	Ring Type Joint

*Pressure Class 600 also available in Ring Type Joint.

GWC can supply any style of gasket required by customer.

HINGE ASSEMBLY

The hinge arm pivots on the hinge pin which is located near the disc's center of gravity. Body penetration for the hinge pin is sealed with a soft steel gasket and flanged plug.

The hinge arm is designed to withstand the shock load of quick closing to insure a longer life and continued shut-off. The hinge arm also has an integral disc stop that provides a positive stop in the open position.

DISC

Each disc's seating surface is precision ground and mated to the seat ring for insurance of a positive shut off. The disc is secured to the hinge arm with the disc nut and pinned to prevent disengagement during service. We can provide either integral or overlaid seat facings at customer's request.

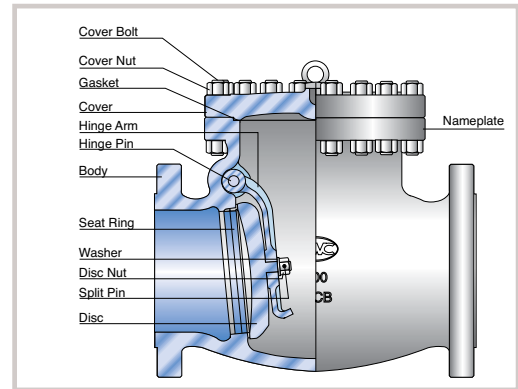

SEAT RING

Seat rings are designed to greatly reduce and/or prevent any turbulence and avoid damages due to corrosion. The seat rings are forged or rolled in one piece and then seal welded and overlaid, if required. After welding and all required heat treating, the seat ring faces are machined, thoroughly cleaned and inspected before leaving for assembly.

BOLTS AND NUTS

For normal service conditions, ASTM A194 Class 2H and ASTM A193 Grade B7 nuts and stud bolts are furnished. If specified for high temperature service conditions, ASTM A194 Class 4 and ASTM A193 Grade B16 nuts and stud bolts are furnished. Standard bolting furnished for our stainless steel valves consists of ASTM A194 Class 8 and ASTM A193 Grade B8 nuts and stud bolts. GWC can supply any bolting as requested by the customer.

END CONNECTIONS

Our standard production covers valves with:

- Flange ends with Raised Face (RF), Flat Face (FF) or Ring Type Joint (RTJ) that conform to B16.5.
- Butt-welding ends (BW) that conform to B16.25.
- All face-to-face/end-to-end dimensions conform to B16.10.
- Other special end connections are supplied according to customer's requirements.

ACCESSORIES/OPTIONAL DESIGNS

Counterweight features are available as an accessory. Piston, tilting disc or API-6D designs are also available to meet the customers requirements. Drains and bypasses are available as specified by the customer.

ORDERING GUIDE

Example: 8" Figure #1900-I-5-GO

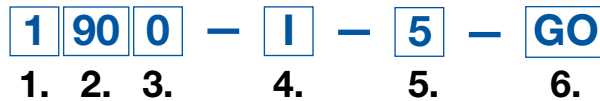

8" CLASS 900 GATE VALVE, FLG-RF, A217 WC6 BODY, WC6 DISC W/STELLITE OVERLAY, F11 SEATS W/STELLITE OVERLAY, F6 STEM, GEAR OP.

1. MODEL

- | | |
|-------------------------------|-------------------------------|
| 1 - API 600 GATE VALVE | 24 - ANGLE GLOBE VALVE |
| 2 - API 600 GLOBE VALVE | 26 - STOP CHECK VALVE |
| 3 - API 600 SWING CHECK VALVE | 34 - TILTING DISC CHECK VALVE |
| 4 - API 603 GATE VALVE | 35 - PISTON CHECK VALVE |
| 5 - API 603 GLOBE VALVE | 81 - API-6D GATE VALVE |
| 6 - API 603 SWING CHECK VALVE | 83 - API-6D SWING CHECK VALVE |

2. RATING

- | | |
|----------------|------------------|
| 15 - CLASS 150 | 90 - CLASS 900 |
| 30 - CLASS 300 | 150 - CLASS 1500 |
| 60 - CLASS 600 | |

3. END CONNECTION

- | | |
|----------------|----------------|
| 0 - RF FLANGED | 9 - RING JOINT |
| 6 - FF FLANGED | X - OTHER |
| 7 - BUTTWELD | |

4. MATERIAL (BODY + BONNET/CAP)

- | | | |
|---------|----------|-------------|
| A - WCB | K - C5 | R - CN7M |
| B - WCC | L - C12 | S - A890 4A |
| C - LCC | M - CF8 | T - A890 5A |
| D - LCB | N - CF8M | U - A890 6A |
| H - WC1 | O - CF3 | X - OTHER |
| I - WC6 | P - CF3M | |
| J - WC9 | Q - CF8C | |

5. MATERIAL (TRIM)

- | | | |
|--------------------------|----------------------------|---------------------------|
| 1 - 13CR | 12 - 316SS 1/2 STELLITE | 17H - 347SS 1/2 STELLITE |
| 8 - 13CR 1/2 STELLITE | 16 - 316SS FULL STELLITE | 17S - 347SS FULL STELLITE |
| 5 - 13CR FULL STELLITE | 9 - MONEL | 21 - F51 |
| 2 - 304SS | 11 - MONEL 1/2 STELLITE | 22 - F53 |
| 2S - 304SS 1/2 STELLITE | 13 - ALLOY 20 | 23 - F55 |
| 15 - 304SS FULL STELLITE | 14 - ALLOY 20 1/2 STELLITE | O - OTHER |
| 10 - 316SS | 17 - 347SS | |

6. OPERATOR

- | | |
|--------------------------|---------------|
| - HANDWHEEL OPERATOR | B - BARE STEM |
| GO - BEVEL GEAR OPERATOR | |

7. SPECIAL REQUIREMENT

- | | |
|---------------------------------|----------------------|
| N - NACE MR-01-75 | EB - EXTENDED BONNET |
| S - SUPPLY COMPLETE INFORMATION | Y - "Y" PATTERN |

CAST STEEL GATE VALVES – STANDARD PARTS & MATERIALS

NO.	PART NAME	CARBON STEEL		ALLOY STEEL				STAINLESS STEEL
		TYPE WCB	TYPE LCC	TYPE WC6	TYPE WC9	TYPE C5	TYPE C12	TYPE CF8M
1	BODY	A216 WCB	A352 LCC	A217 WC6	A217 WC9	A217 C5	A217 C12	A351 CF8M
2	BONNET	A216 WCB	A352 LCC	A217 WC6	A217 WC9	A217 C5	A217 C12	A351 CF8M
3	GATE	A216 WCB+13CR	A352 LCC+316SS	A217 WC6+13CR	A217 WC9+13CR	A217 C5+13CR	A217 C12+13CR	A351 CF8M
4	SEAT RING	A105+STELLITE	LF2+STELLITE	A182 F11+STELLITE	A182 F22+STELLITE	A182 F5+STELLITE	A182 F9+STELLITE	A182 F316+STELLITE
5	YOKE	A216 WCB	A352 LCC	A217 WC6	A217 WC9	A217 C5	A217 C12	A351 CF8M
6	HANDWHEEL	MALLEABLE IRON	MALLEABLE IRON	MALLEABLE IRON	MALLEABLE IRON	MALLEABLE IRON	MALLEABLE IRON	MALLEABLE IRON
7	STEM	A182 F6	A182 F316	A182 F6	A182 F6	A182 F6	A182 F6	A182 F316
8	BACKSEAT BUSHING	A276 410	A276 316	A276 410	A276 410	A276 410	A276 410	A276 316
9	GLAND FLANGE	A216 WCB	A352 LCC	A217 WC6	A217 WC9	A217 C5	A217 C12	A351 CF8M
10	PACKING GLAND	A276 410	A276 316	A276 410	A276 410	A276 410	A276 410	A276 316
11	YOKE CAP	AISI 1045	AISI 1045	AISI 1045	AISI 1045	AISI 1045	AISI 1045	A276 316
12	BONNET BOLT	A193 B7	A320 L7	A193 B16	A193 B16	A193 B16	A193 B16	A193 B8
13	BONNET NUT	A194 2H	A194 4	A194 4	A194 4	A194 4	A194 4	A194 8
14	GLAND EYEBOLT	A193 B7	A320 L7	A193 B16	A193 B16	A193 B16	A193 B16	A193 B8
15	GLAND ADJUSTMENT NUT	A194 2H	A194 4	A194 4	A194 4	A194 4	A194 4	A194 8
16	HANDWHEEL NUT	AISI 1045	AISI 1045	AISI 1045	AISI 1045	AISI 1045	AISI 1045	A276 316
17	GLAND EYEBOLT PIN	AISI 1045	AISI 1045	AISI 1045	AISI 1045	AISI 1045	AISI 1045	A276 316
18	PACKING	BRAIDED GRAPHITE & DIE FORMED GRAPHITE RINGS						
19	GASKET	CLASS 150 316SS GRAPHITE REINFORCED CORRUGATED SHEET / CLASS 300 SPIRAL WOUND 316SS + GRAPHITE / CLASS 600 & ABOVE SOFT RING JOINT						
20	YOKE BOLT	A193 B7	A320 L7	A193 B16	A193 B16	A193 B16	A193 B16	A193 B8
21	YOKE NUT	A194 2H	A194 4	A194 4	A194 4	A194 4	A194 4	A194 8
22	NAMEPLATE	STAINLESS STEEL	STAINLESS STEEL	STAINLESS STEEL	STAINLESS STEEL	STAINLESS STEEL	STAINLESS STEEL	STAINLESS STEEL

Other materials available on request.

MODEL 1150 / 1157 / 1159

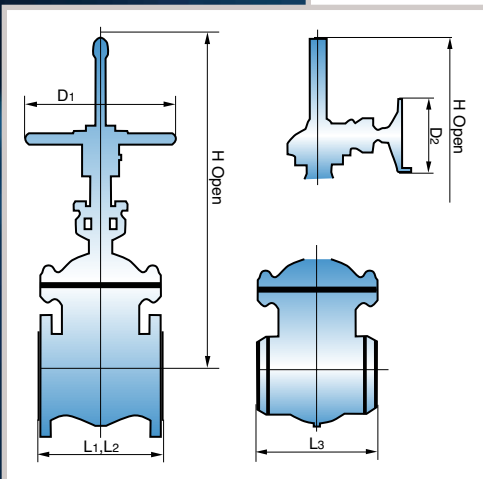

Cast steel gate valve, outside screw and yoke, bolted bonnet, rising stem, non-rising handwheel, flexible wedge, available in welded seat rings, designed according to API-600.

DIMENSIONS

Face to Face	ASME B16.10
End Flange	ASME B16.5*
Buttweld	ASME B16.25
Rating	ASME Class 150

* 26" and larger are available with ASME B16.47 end flanges, either Series A or Series B (formerly MSS SP-44 and API 605).

CLASS 150

Dimensions in inches

Valve Size	1-1/2" 40mm	2" 50mm	2-1/2" 65mm	3" 80mm	4" 100mm	6" 150mm	8" 200mm	10" 250mm	12" 300mm	14" 350mm	16" 400mm	18" 450mm	20" 500mm	24" 600mm	30" 750mm	36" 900mm	
Face to Face	L1: RF	6.50	7.00	7.50	8.00	9.00	10.50	11.50	13.00	14.00	15.00	16.00	17.00	18.00	20.00	24.00	28.00
	L2: RTJ	7.00	7.50	8.00	8.50	9.50	11.00	12.00	13.50	14.50	15.50	16.50	17.50	18.50	20.50	–	–
	L3: BW	6.50	8.50	9.50	11.13	12.00	15.88	16.50	18.00	19.75	22.50	24.00	26.00	28.00	32.00	36.00	40.00
Valve Open Height (H)	12.76	14.45	15.63	18.03	22.05	30.04	37.80	45.91	53.90	59.65	71.80	74.80	83.50	98.50	126.00	140.20	
Handwheel Diameter (D1)	7.09	7.87	7.87	8.82	9.84	12.40	13.98	15.75	17.72	19.69	22.05	24.80	27.95	31.50	35.43	43.00	
Handwheel Diameter (D2)	–	–	–	–	12.40	12.40	12.40	13.98	15.75	15.75	15.75	17.72	17.72	19.69	27.95	31.50	
Weight (lbs).	RF	36	41	58	73	106	192	284	397	618	904	1,279	1,488	1,856	3,042	4,630	6,400
	BW	31	36	47	61	86	166	242	327	513	774	1,126	1,296	1,632	2,703	3,944	6,305

MODEL 1300 / 1307 / 1309

Cast steel gate valve, outside screw and yoke, bolted bonnet, rising stem, non-rising handwheel, flexible wedge, available in welded seat rings, designed according to API-600.

DIMENSIONS

Face to Face	ASME B16.10
End Flange	ASME B16.5*
Buttweld	ASME B16.25
Rating	ASME Class 300

* 26" and larger are available with ASME B16.47 end flanges, either Series A or Series B (formerly MSS SP-44 and API 605).

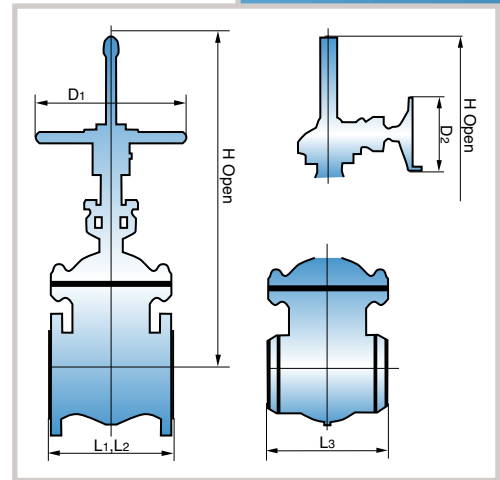

CLASS 300

Dimensions in inches

Valve Size	1-1/2" 40mm	2" 50mm	2-1/2" 65mm	3" 80mm	4" 100mm	6" 150mm	8" 200mm	10" 250mm	12" 300mm	14" 350mm	16" 400mm	18" 450mm	20" 500mm	24" 600mm	30" 750mm	36" 900mm	
Face to Face	L1: RF	7.50	8.50	9.50	11.13	12.00	15.83	16.50	18.00	19.75	30.00	33.00	36.00	39.00	45.00	55.00	68.00
	L2: RTJ	8.00	8.13	10.13	11.83	12.63	16.50	17.13	18.63	20.38	30.63	33.63	36.63	39.75	45.83	56.00	69.00
	L3: BW	7.50	8.50	9.50	11.13	12.00	15.83	16.50	18.00	19.75	30.00	33.00	36.00	39.00	45.00	55.00	68.00
Valve Open Height (H)	15.00	15.94	17.32	19.69	23.31	32.13	41.02	48.31	56.77	62.52	74.41	80.31	86.50	121.18	127.60	159.06	
Handwheel Diameter (D1)	7.87	7.87	7.87	8.82	9.84	13.98	15.75	17.72	19.69	22.05	24.80	27.95	31.50	35.43	51.02	63.00	
Handwheel Diameter (D2)	-	-	-	-	12.40	12.40	12.40	13.98	15.75	15.75	19.69	19.69	19.69	24.80	31.50	51.02	
Weight (lbs).	RF	40	58	75	110	165	317	550	704	1,056	1,496	2,139	2,772	3,545	5,346	8,316	16,698
	BW	29	49	60	84	119	251	462	561	808	1,232	1,793	2,354	3,058	4,367	7,040	14,960

MODEL 1600 / 1607 / 1609

Cast steel gate valve, outside screw and yoke, bolted bonnet, rising stem, non-rising handwheel, flexible wedge, available in welded seat rings, designed according to API-600.

DIMENSIONS

Face to Face	ASME B16.10
End Flange	ASME B16.5*
Buttweld	ASME B16.25
Rating	ASME Class 600

* 26" and larger are available with ASME B16.47 end flanges, either Series A or Series B (formerly MSS SP-44 and API 605).

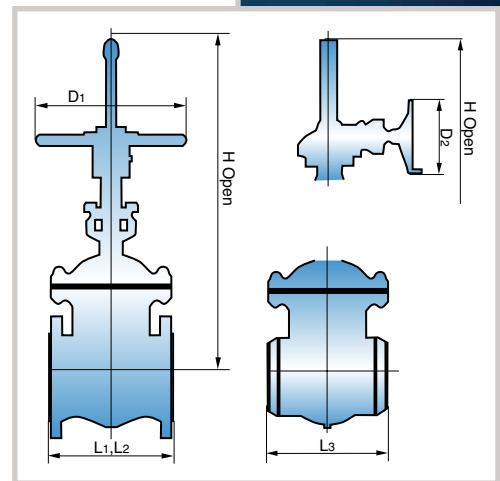

CLASS 600

Dimensions in inches

Valve Size	2" 50mm	2-1/2" 65mm	3" 80mm	4" 100mm	6" 150mm	8" 200mm	10" 250mm	12" 300mm	14" 350mm	16" 400mm	18" 450mm	20" 500mm	24" 600mm	30" 750mm	
Face to Face	L1: RF	11.50	13.00	14.00	17.00	22.00	26.00	31.00	33.00	35.00	39.00	43.00	47.00	55.00	65.00
	L2: RTJ	11.63	13.13	14.13	17.13	22.13	26.13	31.13	33.13	35.13	39.13	43.13	47.25	55.38	65.50
	L3: BW	11.50	13.00	14.00	17.00	22.00	26.00	31.00	33.00	35.00	39.00	43.00	47.00	55.00	65.00
Valve Open Height (H)	16.65	17.99	20.12	25.00	37.72	42.44	48.86	56.69	50.09	71.06	78.11	79.92	107.00	155.98	
Handwheel Diameter (D1)	7.87	8.82	9.84	13.98	17.72	19.69	24.80	27.95	31.50	35.43	35.43	42.99	42.99	63.00	
Handwheel Diameter (D2)	-	-	-	12.40	15.75	17.72	19.69	22.05	24.80	27.96	27.96	31.50	31.50	35.43	
Weight (lbs).	RF	80	113	143	277	532	935	1,385	1,984	2,658	3,108	4,891	6,197	8,656	14,840
	BW	69	97	122	220	423	744	1,102	1,578	2,283	2,473	42,40	5,371	7,473	12,810

CAST STEEL GATE VALVES – STANDARD PARTS & MATERIALS

MODEL 1900 / 1907 / 1909

Cast steel gate valve, outside screw and yoke, bolted bonnet, rising stem, non-rising handwheel, flexible wedge, available in welded seat rings, designed according to API-600.

DIMENSIONS

Face to Face	ASME B16.10
End Flange	ASME B16.5
Buttweld	ASME B16.25
Rating	ASME Class 900

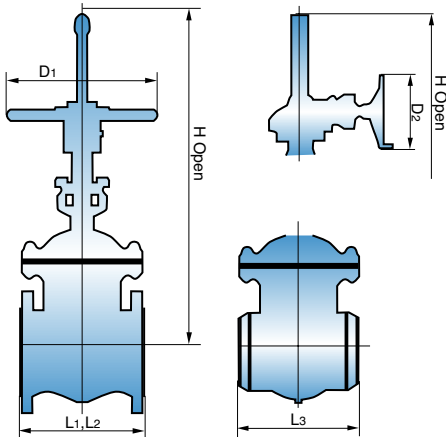

Dimensions in inches

CLASS 900

Valve Size		2" 50mm	3" 80mm	4" 100mm	6" 150mm	8" 200mm	10" 250mm	12" 300mm	14" 350mm	16" 400mm	18" 450mm	20" 500mm	24" 600mm
Face to Face	L1: RF	14.50	15.00	18.00	24.00	29.00	33.00	38.00	40.50	44.50	48.00	52.00	61.00
	L2: RTJ	14.63	15.13	18.13	24.13	29.13	33.13	38.13	40.87	44.87	48.50	52.50	61.75
	L3: BW	14.50	15.00	18.00	24.00	29.00	33.00	38.00	40.50	44.50	48.00	52.00	61.00
Valve Open Height (H)		18.66	23.03	27.64	37.72	50.98	57.13	65.16	72.52	84.61	87.80	97.10	111.81
Handwheel Diameter (D1)		9.84	13.98	13.98	19.69	24.80	24.80	31.50	35.43	35.43	42.99	42.99	42.99
Handwheel Diameter (D2)		–	–	–	17.72	22.05	24.80	24.80	27.95	27.95	31.50	35.43	35.43
Weight (lbs).	RF	178	219	307	750	1,279	1,963	3,160	4,395	5,940	7,662	9,620	14,454
	BW	165	191	251	641	1,113	1,552	2,670	3,740	5,078	6,534	8,010	12,117

MODEL 11500 / 11507 / 11509

Cast steel gate valve, outside screw and yoke, bolted bonnet, rising stem, non-rising handwheel, flexible wedge, available in welded seat rings, designed according to API-600.

DIMENSIONS

Face to Face	ASME B16.10
End Flange	ASME B16.5
Buttweld	ASME B16.25
Rating	ASME Class 1500

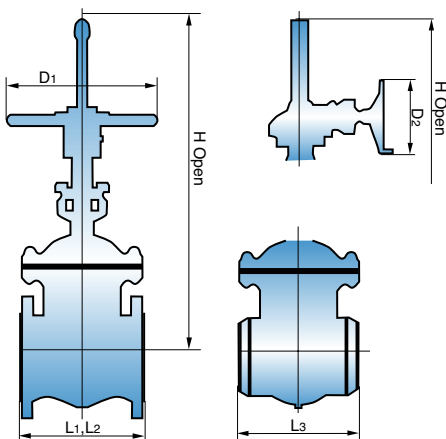

Dimensions in inches

CLASS 1500

Valve Size		2" 50mm	3" 80mm	4" 100mm	6" 150mm	8" 200mm	10" 250mm	12" 300mm	14" 350mm	16" 400mm	18" 450mm	20" 500mm	24" 600mm
Face to Face	L1: RF	14.50	18.50	21.50	27.75	32.72	39.00	44.50	48.50	54.50	60.50	65.50	76.50
	L2: RTJ	14.63	18.63	21.63	28.00	33.13	39.37	45.12	50.25	55.37	61.30	66.37	77.63
	L3: BW	14.50	18.50	21.50	27.75	32.72	39.00	44.50	49.50	54.50	60.50	65.50	76.50
Valve Open Height (H)		18.66	23.74	28.70	37.17	53.50	57.13	67.13	74.49	90.12	93.31	104.96	119.69
Handwheel Diameter (D1)		9.84	13.98	13.98	19.69	24.80	24.80	35.43	35.43	35.43	35.43	35.43	–
Handwheel Diameter (D2)		–	–	17.72	17.72	27.95	27.95	27.95	31.50	35.43	35.43	42.99	42.99
Weight (lbs).	RF	178	312	529	1,114	2,351	3,840	6,464	8,150	13,300	17,820	22,037	32,210
	BW	165	246	423	896	2,058	3,050	5,270	6,340	11,800	15,325	18,920	27,264

CAST STEEL GLOBE & ANGLE VALVES – STANDARD PARTS & MATERIALS

NO.	PART NAME	CARBON STEEL		ALLOY STEEL				STAINLESS STEEL
		TYPE WCB	TYPE LCC	TYPE WC6	TYPE WC9	TYPE C5	TYPE C12	TYPE CF8M
1	BODY	A216 WCB	A352 LCC	A217 WC6	A217 WC9	A217 C5	A217 C12	A351 CF8M
2	BONNET	A216 WCB	A352 LCC	A217 WC6	A217 WC9	A217 C5	A217 C12	A351 CF8M
3	GATE	A216 WCB+13CR	A352 LCC+316SS	A217 WC6+13CR	A217 WC9+13CR	A217 C5+13CR	A217 C12+13CR	A351 CF8M
4	SEAT RING	A105+STELLITE	LF2+STELLITE	A182 F11+STELLITE	A182 F22+STELLITE	A182 F5+STELLITE	A182 F9+STELLITE	A182 F316+STELLITE
5	HANDWHEEL	MALLEABLE IRON	MALLEABLE IRON	MALLEABLE IRON	MALLEABLE IRON	MALLEABLE IRON	MALLEABLE IRON	MALLEABLE IRON
6	STEM	A182 F6	A182 F316	A182 F6	A182 F6	A182 F6	A182 F6	A182 F316
7	BACKSEAT BUSHING	A276 410	A276 316	A276 410	A276 410	A276 410	A276 410	A276 316
8	GLAND FLANGE	A216 WCB	A352 LCC	A217 WC6	A217 WC9	A217 C5	A217 C12	A351 CF8M
9	PACKING GLAND	A276 410	A276 316	A276 410	A276 410	A276 410	A276 410	A276 316
10	BONNET BOLT	A193 B7	A320 L7	A193 B16	A193 B16	A193 B16	A193 B16	A193 B8
11	BONNET NUT	A194 2H	A194 4	A194 4	A194 4	A194 4	A194 4	A194 8
12	GLAND EYEBOLT	A193 B7	A320 L7	A193 B16	A193 B16	A193 B16	A193 B16	A193 B8
13	GLAND ADJUSTMENT NUT	A194 2H	A194 4	A194 4	A194 4	A194 4	A194 4	A194 8
14	HANDWHEEL NUT	AISI 1045	AISI 1045	AISI 1045	AISI 1045	AISI 1045	AISI 1045	A276 316
15	GLAND EYEBOLT PIN	AISI 1045	AISI 1045	AISI 1045	AISI 1045	AISI 1045	AISI 1045	A276 316
16	DISC NUT	A276 410	A276 316	A276 410	A276 410	A276 410	A276 410	A276 316
17	PACKING	BRAIDED GRAPHITE & DIE FORMED GRAPHITE RINGS						
18	GASKET	CLASS 150 & 300 SPIRAL WOUND 316SS + GRAPHITE / CLASS 600 & ABOVE SOFT RING JOINT						
19	NAMEPLATE	STAINLESS STEEL	STAINLESS STEEL	STAINLESS STEEL	STAINLESS STEEL	STAINLESS STEEL	STAINLESS STEEL	STAINLESS STEEL

Other materials available on request.

MODEL 2150 / 2157 / 2159

Cast steel globe valve, outside screw and yoke, bolted bonnet, rising stem, rising handwheel, swivel plug disc. Available in welded seat rings designed according to API-600/ASME B16.34.

DIMENSIONS

Face to Face	ASME B16.10
End Flange	ASME B16.5
Buttweld	ASME B16.25
Rating	ASME Class 150

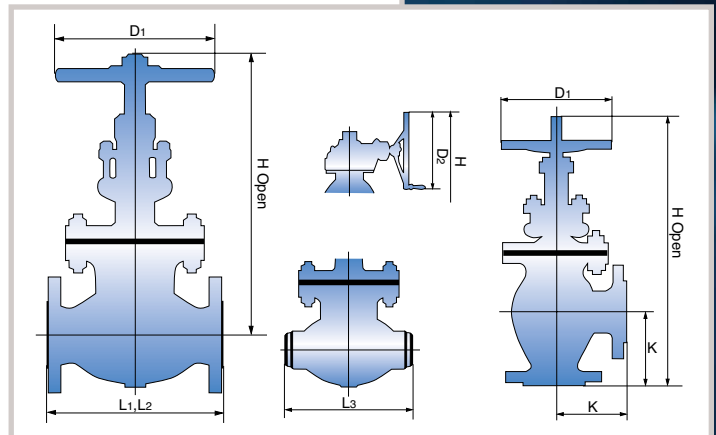

Dimensions in inches

Valve Size	1-1/2" 40mm	2" 50mm	2-1/2" 65mm	3" 80mm	4" 100mm	6" 150mm	8" 200mm	10" 250mm	12" 300mm	14" 350mm	16" 400mm	18" 450mm	20" 500mm
Face to Face	L1: RF	6.50	8.00	8.50	9.50	11.50	16.00	19.50	24.50	27.50	31.00	36.00	38.50
	L2: RTJ	7.00	8.50	9.00	10.00	12.00	16.50	20.00	25.00	28.00	31.50	36.50	39.00
	L3: BW	6.50	8.00	8.50	9.50	11.50	16.00	19.50	24.50	27.50	31.00	36.00	38.50
	K: RF/BW	3.25	4.00	4.25	4.75	5.75	8.00	9.75	12.25	13.75	15.50	18.00	—
Valve Open Height (H)	11.42	12.44	12.99	14.37	16.30	19.87	24.53	31.61	33.03	52.99	60.98	70.00	78.98
Handwheel Diameter (D1)	7.09	2.87	2.87	8.82	11.02	13.98	15.75	17.72	19.69	22.05	24.80	31.50	31.50
Handwheel Diameter (D2)	—	—	—	—	—	13.98	17.72	17.72	19.69	22.05	24.80	27.95	31.50
Weight (lbs).	RF	38	46	62	75	114	209	371	534	891	1,365	1,808	2,822
	BW	33	36	53	60	90	163	316	426	786	1,234	1,655	2,597

CLASS 150

CAST STEEL GLOBE & ANGLE VALVES – MODEL 2300 /2307 / 2309

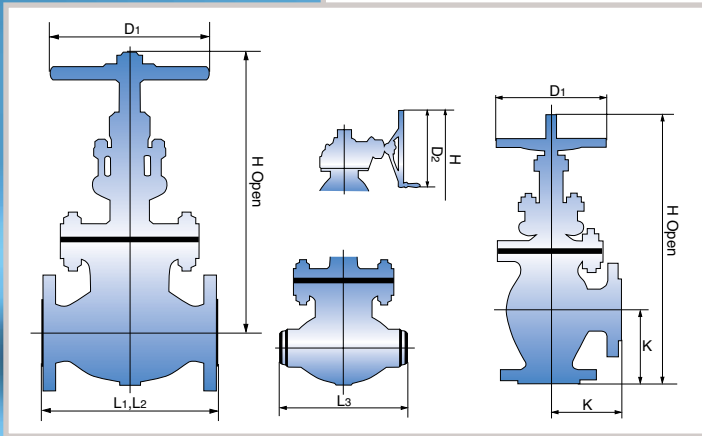

Cast steel globe valve, outside screw and yoke, bolted bonnet, rising stem, rising handwheel, swivel plug disc. Available in welded seat rings designed according to API-600/ASME B16.34.

DIMENSIONS

Face to Face	ASME B16.10
End Flange	ASME B16.5
Buttweld	ASME B16.25
Rating	ASME Class 300

Dimensions in inches

CLASS 300

Valve Size	2" 50mm	2-1/2" 65mm	3" 80mm	4" 100mm	6" 150mm	8" 200mm	10" 250mm	12" 300mm	14" 350mm	16" 400mm
Face to Face	L1: RF	10.50	11.50	12.50	14.00	17.50	22.00	24.50	28.00	34.00
	L2: RTJ	11.13	12.13	13.13	14.63	18.13	22.63	25.13	28.63	34.63
	L3: BW	10.50	11.50	12.50	14.00	17.50	22.00	24.50	28.00	34.00
	K: RF/BW	5.25	5.75	6.25	7.00	8.75	11.00	12.25	14.00	–
Valve Open Height (H)	13.78	15.39	16.54	19.37	24.41	31.22	45.08	49.61	55.28	62.99
Handwheel Diameter (D1)	7.87	8.82	11.02	13.98	17.72	22.05	22.05	24.80	27.95	27.95
Handwheel Diameter (D2)	–	–	–	–	17.72	19.69	22.05	24.80	24.80	27.96
Weight (lbs).	RF	58	88	116	176	370	1,005	1,340	2,008	2,650
	BW	53	80	94	142	299	440	860	1,143	2,260

MODEL 2600 / 2607 / 2609

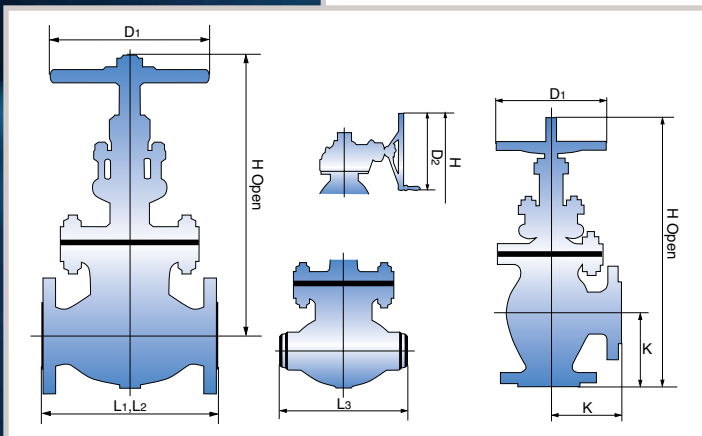

Cast steel globe valve, outside screw and yoke, bolted bonnet, rising stem, rising handwheel, swivel plug disc. Available in welded seat rings designed according to API-600/ASME B16.34.

DIMENSIONS

Face to Face	ASME B16.10
End Flange	ASME B16.5
Buttweld	ASME B16.25
Rating	ASME Class 600

Dimensions in inches

CLASS 600

Valve Size	2" 50mm	2-1/2" 65mm	3" 80mm	4" 100mm	6" 150mm	8" 200mm	10" 250mm	12" 300mm
Face to Face	L1: RF	11.50	13.00	14.00	17.00	22.00	26.00	31.00
	L2: RTJ	11.63	13.13	14.13	17.13	22.13	26.13	31.13
	L3: BW	11.50	13.00	14.00	17.00	22.00	26.00	31.00
	K: RF/BW	5.25	5.75	6.25	8.00	9.75	11.75	15.00
Valve Open Height (H)	15.43	17.00	18.82	20.87	26.57	28.39	38.27	42.28
Handwheel Diameter (D1)	8.82	11.02	12.40	13.98	19.69	22.05	24.80	27.95
Handwheel Diameter (D2)	–	–	–	13.98	19.69	22.05	22.05	24.80
Weight (lbs).	RF	82	89	137	253	525	800	1,505
	BW	68	70	109	198	415	637	1,235

CAST STEEL GLOBE & ANGLE VALVES

Cast steel globe valve, outside screw and yoke, bolted bonnet, rising stem, rising handwheel, swivel plug disc. Available in welded seat rings designed according to API-600/ASME B16.34.

DIMENSIONS

Face to Face	ASME B16.10
End Flange	ASME B16.5
Buttweld	ASME B16.25
Rating	ASME Class 900

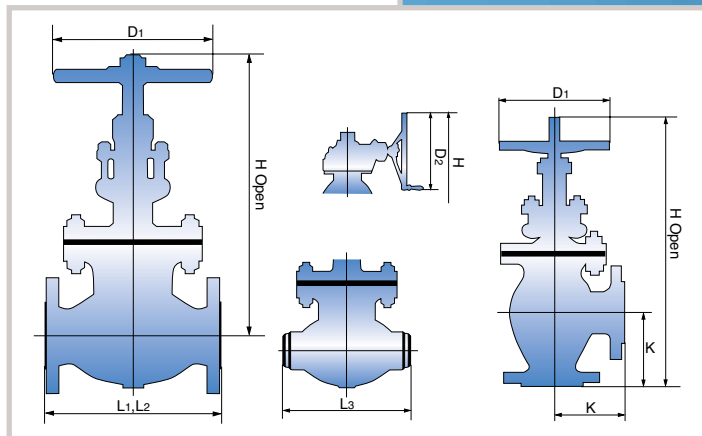

Dimensions in inches

Valve Size		2" 50mm	3" 80mm	4" 100mm	6" 150mm	8" 200mm	10" 250mm	12" 300mm
Face to Face	L1: RF	14.50	15.00	18.00	24.00	29.00	33.00	38.00
	L2: RTJ	14.63	15.13	18.13	24.13	29.13	33.13	38.13
	L3: BW	14.50	15.00	18.00	24.00	29.00	33.00	38.00
	K: RF/BW	7.25	7.50	9.00	12.00	-	-	-
Valve Open Height (H)		19.57	20.20	23.74	28.70	38.10	55.40	61.00
Handwheel Diameter (D1)		12.40	13.98	15.75	22.05	24.80	27.95	31.50
Handwheel Diameter (D2)		-	-	15.75	19.69	22.05	24.80	27.95
Weight (lbs).	RF	215	225	390	920	2,673	4,050	5,247
	BW	160	180	330	650	2,370	3,700	4,752

CLASS 900

MODEL 21500 / 21507 / 21509

Cast steel globe valve, outside screw and yoke, bolted bonnet, rising stem, rising handwheel, swivel plug disc. Available in welded seat rings designed according to API-600/ASME B16.34.

DIMENSIONS

Face to Face	ASME B16.10
End Flange	ASME B16.5
Buttweld	ASME B16.25
Rating	ASME Class 1500

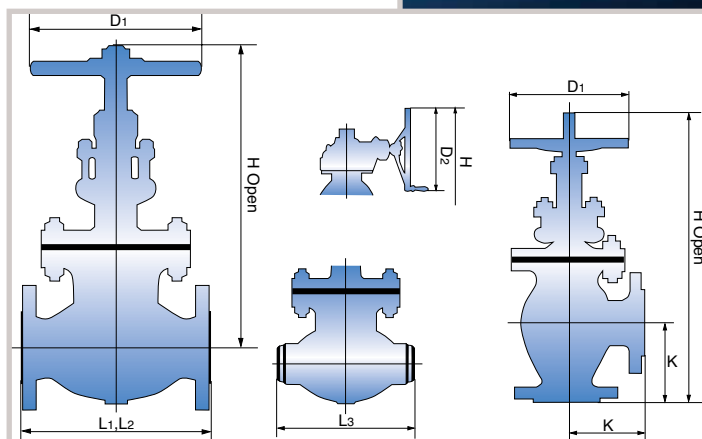

Dimensions in inches

Valve Size		2" 50mm	3" 80mm	4" 100mm	6" 150mm	8" 200mm	10" 250mm	12" 300mm
Face to Face	L1: RF	14.50	18.50	21.50	27.75	32.75	39.00	44.50
	L2: RTJ	14.62	18.62	21.62	28.00	33.12	39.38	45.13
	L3: BW	14.50	18.50	21.50	27.75	32.75	39.00	44.50
	K: RF/BW	7.25	8.25	9.25	10.75	13.88	-	-
Valve Open Height (H)		19.57	23.00	28.10	36.00	46.90	58.00	65.00
Handwheel Diameter (D1)		12.40	15.75	15.75	20.00	24.80	28.00	31.50
Handwheel Diameter (D2)		-	13.98	15.75	24.80	27.96	31.50	31.50
Weight (lbs).	RF	215	462	772	1,810	4,170	6,330	8,712
	BW	160	265	425	1,500	3,540	5,544	7,524

CLASS 1500

CAST STEEL SWING CHECK VALVES

STANDARD PARTS & MATERIALS

NO.	PART NAME	CARBON STEEL		ALLOY STEEL				STAINLESS STEEL
		TYPE WCB	TYPE LCC	TYPE WC6	TYPE WC9	TYPE C5	TYPE C12	TYPE CF8M
1	BODY	A216 WCB	A352 LCC	A217 WC6	A217 WC9	A217 C5	A217 C12	A351 CF8M
2	COVER	A216 WCB	A352 LCC	A217 WC6	A217 WC9	A217 C5	A217 C12	A351 CF8M
3	DISC	A216 WCB+13CR	A352 LCC+316SS	A217 WC6+13CR	A217 WC9+13CR	A217 C5+13CR	A217 C12+13CR	A351 CF8M
4	SEAT RING	A105+STELLITE	LF2+STELLITE	A182 F11+STELLITE	A182 F22+STELLITE	A182 F5+STELLITE	A182 F9+STELLITE	A182 F316+STELLITE
5	HINGE	A216 WCB	A352 LCC	A217 WC6	A217 WC9	A217 C5	A217 C12	A351 CF8M
6	HINGE PIN	A276 410	A276 316	A276 410	A276 410	A276 410	A276 410	A276 316
7	DISC NUT	A193 B7	A320 L7	A193 B16	A193 B16	A193 B16	A193 B16	A193 B8
8	DISC WASHER	CARBON STEEL	CARBON STEEL	CARBON STEEL	CARBON STEEL	CARBON STEEL	CARBON STEEL	STAINLESS STEEL
9	SPLIT PIN	A276 410	A276 316	A276 410	A276 410	A276 410	A276 410	A276 316
10	COVER BOLT	A193 B7	A320 L7	A193 B16	A193 B16	A193 B16	A193 B16	A193 B8
11	COVER NUT	A194 2H	A194 4	A194 4	A194 4	A194 4	A194 4	A194 8
12	EYE BOLT	ASTM A181	ASTM A181	ASTM A181	ASTM A181	ASTM A181	ASTM A181	ASTM A181
13	GASKET	CLASS 150 & 300 SPIRAL WOUND 316SS + GRAPHITE / CLASS 600 & ABOVE SOFT RING JOINT						
14	NAMEPLATE	STAINLESS STEEL	STAINLESS STEEL	STAINLESS STEEL	STAINLESS STEEL	STAINLESS STEEL	STAINLESS STEEL	STAINLESS STEEL

Other materials available on request.

MODEL 3150 / 3157 / 3159

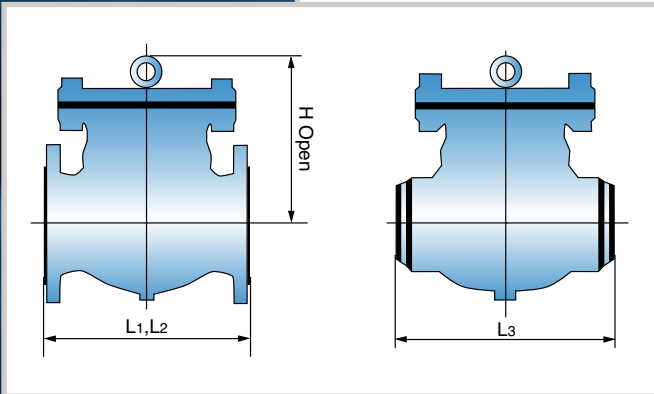

Cast steel swing check valve, horizontal or vertical lines, bolted cover, available in welded seat rings, designed according to API-600/ASME B16.34

DIMENSIONS

Face to Face	ASME B16.10
End Flange	ASME B16.5*
Buttweld	ASME B16.25
Rating	ASME Class 150

* 26" and larger are available with ASME B16.47 end flanges, either Series A or Series B (formerly MSS SP-44 and API 605).

CLASS 150

Dimensions in inches

Valve Size	1-1/2" 40mm	2" 50mm	2-1/2" 65mm	3" 80mm	4" 100mm	6" 150mm	8" 200mm	10" 250mm	12" 300mm	14" 350mm	16" 400mm	18" 450mm	20" 500mm	24" 600mm	30" 750mm	36" 900mm	
Face to Face	L1: RF	6.50	8.00	8.50	9.50	11.50	14.00	19.50	24.50	27.50	31.00	34.00	38.50	38.50	51.00	60.00	77.00
	L2: RTJ	7.00	8.50	9.00	10.00	12.00	14.50	20.00	25.00	28.00	31.50	34.50	39.00	39.00	51.50	60.50	77.50
	L3: BW	6.50	8.00	8.50	9.50	11.50	14.00	19.50	24.50	27.50	31.00	34.00	38.50	38.50	51.00	60.00	77.00
Valve Open Height (H)	5.11	6.30	6.70	7.49	8.87	10.18	12.60	13.72	14.96	15.79	18.11	19.88	22.20	26.89	36.00	41.50	
Weight (lbs).	RF	33	38	48	68	110	203	299	430	628	926	1,102	1,411	1,720	3,285	5,077	8,160
	BW	28	31	38	56	95	183	266	284	572	804	980	1,160	1,495	2,945	4,315	7,010

CAST STEEL SWING CHECK VALVES

Cast steel swing check valve, horizontal or vertical lines, bolted cover, available in welded seat rings, designed according to API-600/ASME B16.34

DIMENSIONS

Face to Face	ASME B16.10
End Flange	ASME B16.5*
Buttweld	ASME B16.25
Rating	ASME Class 300

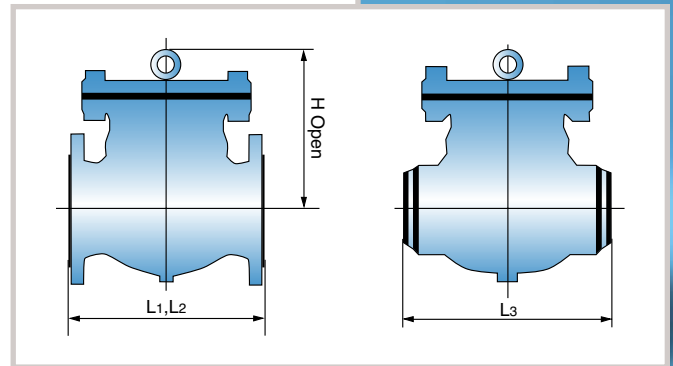

* 26" and larger are available with ASME B16.47 end flanges, either Series A or Series B (formerly MSS SP-44 and API 605).

Dimensions in inches

Valve Size		2" 50mm	2-1/2" 65mm	3" 80mm	4" 100mm	6" 150mm	8" 200mm	10" 250mm	12" 300mm	14" 350mm	16" 400mm	18" 450mm	20" 500mm	24" 600mm	30" 750mm	36" 900mm
Face to Face	L1: RF	10.50	11.50	12.50	14.00	17.50	21.00	24.50	28.00	33.00	34.00	38.50	40.00	53.00	62.75	82.00
	L2: RTJ	11.13	12.13	13.33	14.63	18.13	21.63	25.13	28.63	33.63	34.63	39.13	40.75	53.88	63.75	83.00
	L3: BW	10.50	11.50	12.50	14.00	17.50	21.00	24.50	28.00	33.00	34.00	38.50	40.00	53.00	62.75	82.00
Valve Open Height (H)		6.30	7.44	7.83	8.94	10.94	12.68	15.08	17.13	20.08	20.51	22.52	24.76	28.03	37.00	42.99
Weight (lbs).	RF	56	72	108	160	299	406	657	916	1,503	1,649	2,097	2,494	4,500	5,850	10,500
	BW	43	55	88	102	240	317	525	750	1,241	1,305	1,803	2,150	3,870	5,020	9,450

CLASS 300

MODEL 3600 / 3607 / 3609

Cast steel swing check valve, horizontal or vertical lines, bolted cover, available in welded seat rings, designed according to API-600/ASME B16.34

DIMENSIONS

Face to Face	ASME B16.10
End Flange	ASME B16.5
Buttweld	ASME B16.25
Rating	ASME Class 600

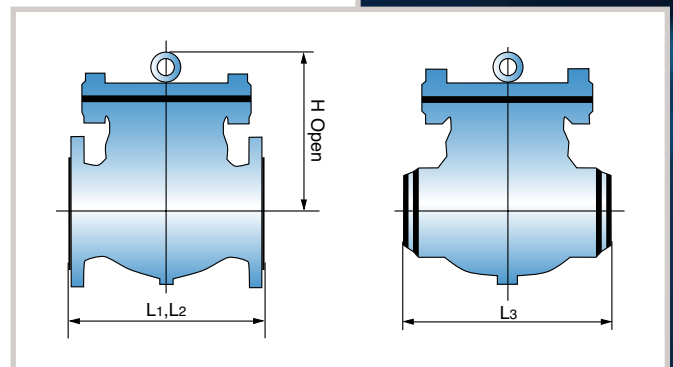

Dimensions in inches

Valve Size		2" 50mm	3" 80mm	4" 100mm	6" 150mm	8" 200mm	10" 250mm	12" 300mm	14" 350mm	16" 400mm	18" 450mm	20" 500mm	24" 600mm
Face to Face	L1: RF	11.50	14.00	17.00	22.00	26.00	31.00	33.00	35.00	39.00	43.00	47.00	55.00
	L2: RTJ	11.63	14.13	17.13	22.13	26.13	31.13	33.13	35.13	39.13	43.13	47.25	55.38
	L3: BW	11.50	14.00	17.00	22.00	26.00	31.00	33.00	35.00	39.00	43.00	47.00	55.00
Valve Open Height (H)		7.38	8.25	10.06	12.94	14.31	18.25	19.13	22.50	26.00	28.00	31.00	34.00
Weight (lbs).	RF	71	130	247	474	849	1,351	1,918	2,068	2,976	4,451	5,269	6,634
	BW	66	110	223	364	686	1,081	1,605	1,693	2,469	3,802	4,443	5,137

CLASS 600

CAST STEEL SWING CHECK VALVES – MODEL 3900 / 3907 /3909

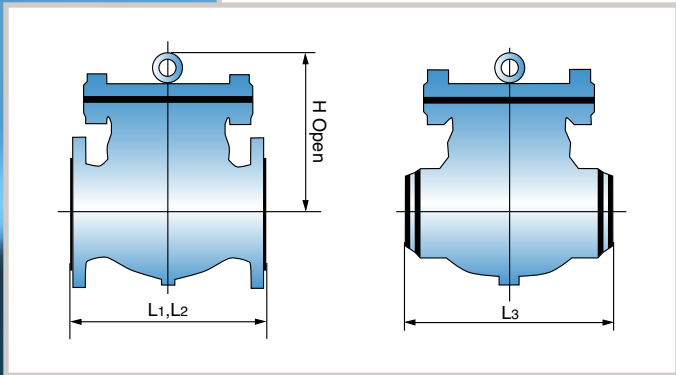

Cast steel swing check valve, horizontal or vertical lines, bolted cover, available in welded seat rings, designed according to API-600/ASME B16.34

DIMENSIONS

Face to Face	ASME B16.10
End Flange	ASME B16.5
Buttweld	ASME B16.25
Rating	ASME Class 900

CLASS 900

Dimensions in inches

Valve Size		2" 50mm	3" 80mm	4" 100mm	6" 150mm	8" 200mm	10" 250mm	12" 300mm	14" 350mm	16" 400mm	18" 450mm	20" 500mm	24" 600mm
Face to Face	L1: RF	14.50	15.00	18.00	24.00	29.00	33.00	38.00	40.50	44.50	48.00	52.00	61.00
	L2: RTJ	14.63	15.13	18.13	24.13	29.13	33.13	38.13	40.87	44.87	48.50	52.50	61.75
	L3: BW	14.50	15.00	18.00	24.00	29.00	33.00	38.00	40.50	44.50	48.00	52.00	61.00
Valve Open Height (H)		10.51	11.42	12.05	13.31	18.11	19.69	22.75	25.47	27.95	30.90	33.46	36.61
Weight (lbs).	RF	161	181	307	582	1,210	1,800	3,200	3,850	5,324	7,150	8,800	12,760
	BW	119	136	235	247	1,010	1,545	2,720	3,190	4,510	5,940	7,260	9,900

MODEL 31500 / 31507 / 31509

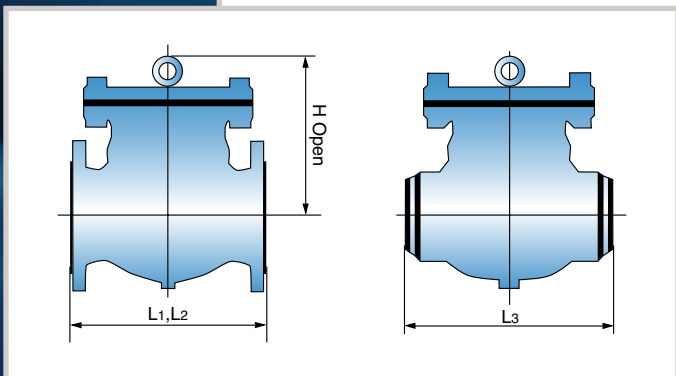

Cast steel swing check valve, horizontal or vertical lines, bolted cover, available in welded seat rings, designed according to API-600/ASME B16.34

DIMENSIONS

Face to Face	ASME B16.10
End Flange	ASME B16.5
Buttweld	ASME B16.25
Rating	ASME Class 1500

CLASS 1500

Dimensions in inches

Valve Size		2" 50mm	3" 80mm	4" 100mm	6" 150mm	8" 200mm	10" 250mm	12" 300mm	14" 350mm	16" 400mm	18" 450mm	20" 500mm	24" 600mm
Face to Face	L1: RF	14.50	18.50	21.50	27.75	32.75	39.00	44.50	49.50	54.50	60.50	65.50	76.50
	L2: RTJ	14.63	18.63	21.63	28.00	33.13	39.37	45.12	50.25	55.37	61.37	66.37	77.63
	L3: BW	14.50	18.50	21.50	27.75	32.75	39.00	44.50	49.50	54.50	60.50	65.50	76.50
Valve Open Height (H)		10.51	11.65	13.98	18.31	21.26	22.64	26.38	28.54	31.89	35.63	39.57	44.27
Weight (lbs).	RF	161	276	467	1,067	2,356	3,663	5,445	7,128	9,700	13,060	16,130	23,265
	BW	119	209	362	813	1,910	2,930	4,310	5,600	7,720	10,395	12,770	17,820

CAST STAINLESS STEEL GATE VALVES – STANDARD PARTS & MATERIALS

STANDARD PARTS & MATERIALS

NO.	PART NAME	STAINLESS STEEL				
		TYPE CF8M	TYPE CF8	TYPE CF3M	TYPE CF3	TYPE CN7M
1	BODY	A351 CF8M	A351 CF8	A351 CF3M	A351 CF3	A351 CN7M
2	BONNET	A351 CF8M	A351 CF8	A351 CF3M	A351 CF3	A351 CN7M
3	GATE	A351 CF8M	A351 CF8	A351 CF3M	A351 CF3	A351 CN7M
4	HANDWHEEL	MALLEABLE IRON	MALLEABLE IRON	MALLEABLE IRON	MALLEABLE IRON	MALLEABLE IRON
5	STEM	A182 F316	A182 F304	A182 F316	A182 F304	B473
6	BACKSEAT BUSHING	A276 316	A276 304	A276 316	A276 304	A276 CN7M
7	GLAND FLANGE	A351 CF8M	A351 CF8	A351 CF3M	A351 CF3	A351 CN7M
8	PACKING GLAND	A276 316	A276 304	A276 316	A276 304	A276 316
9	BONNET BOLT	A193 B8	A193 B8	A193 B8	A193 B8	A193 B8
10	BONNET NUT	A194 8	A194 8	A194 8	A194 8	A194 8
11	GLAND EYEBOLT	A193 B8	A193 B8	A193 B8	A193 B8	A193 B8
12	GLAND ADJUSTMENT NUT	A194 8	A194 8	A194 8	A194 8	A194 8
13	HANDWHEEL NUT	A276 316	A276 304	A276 316	A276 304	A276 316
14	GLAND EYEBOLT PIN	A276 316	A276 304	A276 316	A276 304	A276 316
15	PACKING	TEFLON				
16	GASKET	TEFLON				
17	NAMEPLATE	STAINLESS STEEL	STAINLESS STEEL	STAINLESS STEEL	STAINLESS STEEL	STAINLESS STEEL

MODEL 4150 / 4300

Cast stainless steel gate valve, outside screw and yoke, bolted bonnet, rising stem, non rising handwheel, flexible wedge for Class 150 on 3" and larger and 2" and larger for Class 300. Integral seat designed according to API-603, ASME B16.34.

DIMENSIONS

Face to Face	ASME B16.10
End Flange	ASME B16.5
Buttweld	ASME B16.25
Rating	ASME Class 150/300

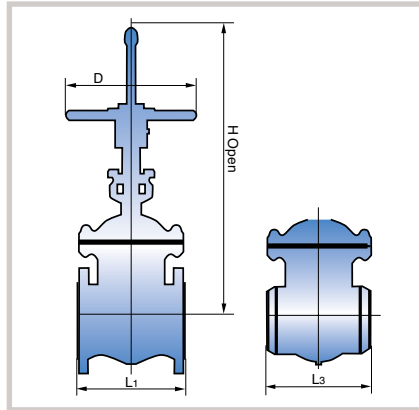

Dimensions in inches

Valve Size	1/2" 15mm	3/4" 20mm	1" 25mm	1-1/2" 40mm	2" 50mm	2-1/2" 65mm	3" 80mm	4" 100mm	6" 150mm	8" 200mm	10" 250mm	12" 300mm	
Face to Face	L1: RF L3: BW	4.25	4.63	5.00	6.50	7.00	7.50	8.00	9.00	10.50	11.50	13.00	14.00
Valve Open Height (H)		7.48	7.83	9.17	11.22	13.11	15.08	16.69	20.86	28.74	36.85	43.86	53.89
Handwheel Diameter (D)		3.94	3.94	4.72	5.51	6.30	7.09	7.87	9.84	12.40	13.98	13.98	17.72
Weight (lbs).		4.85	6.20	9.94	19.20	28.00	38.85	48.00	75.50	126.00	213.00	291.40	434.90

Dimensions in inches

Valve Size	1/2" 15mm	3/4" 20mm	1" 25mm	1-1/2" 40mm	2" 50mm	2-1/2" 65mm	3" 80mm	4" 100mm	6" 150mm	8" 200mm	10" 250mm	12" 300mm	
Face to Face	L1: RF L3: BW	5.50	6.00	6.50	7.50	8.50	9.50	11.13	12.00	15.88	16.50	18.00	19.75
Valve Open Height (H)		8.19	8.30	11.93	13.74	15.35	17.00	19.33	23.15	31.57	39.45	47.87	62.28
Handwheel Diameter (D)		3.93	3.93	4.72	7.09	7.87	7.87	8.82	9.84	13.98	15.75	17.72	19.69
Weight (lbs).		8.00	10.20	20.30	31.80	49.70	77.30	88.30	173.70	310.00	445.00	657.00	942.60

CLASS 150

CLASS 300

CAST STAINLESS STEEL GLOBE VALVES

STANDARD PARTS & MATERIALS

NO.	PART NAME	STAINLESS STEEL				
		TYPE CF8M	TYPE CF8	TYPE CF3M	TYPE CF3	TYPE CN7M
1	BODY	A351 CF8M	A351 CF8	A351 CF3M	A351 CF3	A351 CN7M
2	BONNET	A351 CF8M	A351 CF8	A351 CF3M	A351 CF3	A351 CN7M
3	GATE	A351 CF8M	A351 CF8	A351 CF3M	A351 CF3	A351 CN7M
4	HANDWHEEL	MALLEABLE IRON	MALLEABLE IRON	MALLEABLE IRON	MALLEABLE IRON	MALLEABLE IRON
5	STEM	A182 F316	A182 F304	A182 F316	A182 F304	B473
6	BACKSEAT BUSHING	A276 316	A276 304	A276 316	A276 304	A276 316
7	GLAND FLANGE	A351 CF8M	A351 CF8	A351 CF3M	A351 CF3	A351 CN7M
8	PACKING GLAND	A276 316	A276 304	A276 316	A276 304	A276 316
9	BONNET BOLT	A193 B8	A193 B8	A193 B8	A193 B8	A193 B8
10	BONNET NUT	A194 8	A194 8	A194 8	A194 8	A194 8
11	GLAND EYEBOLT	A193 B8	A193 B8	A193 B8	A193 B8	A193 B8
12	GLAND ADJUSTMENT NUT	A194 8	A194 8	A194 8	A194 8	A194 8
13	HANDWHEEL NUT	A276 316	A276 304	A276 316	A276 304	A276 316
14	GLAND EYEBOLT PIN	A276 316	A276 304	A276 316	A276 304	A276 316
15	DISC NUT	A276 316	A276 304	A276 316	A276 304	A276 316
16	PACKING	TEFLON				
17	GASKET	TEFLON				
18	NAMEPLATE	STAINLESS STEEL	STAINLESS STEEL	STAINLESS STEEL	STAINLESS STEEL	STAINLESS STEEL

MODEL 5150 / 5300



Cast stainless steel globe valve, outside screw and yoke, bolted bonnet, rising stem, non rising handwheel, swivel plug disc. Integral seat designed according to API-603, ASME B16.34.

DIMENSIONS

Face to Face	ASME B16.10
End Flange	ASME B16.5
Buttweld	ASME B16.25
Rating	ASME Class 150/300

Dimensions in inches

CLASS 150

Valve Size		1/2" 15mm	3/4" 20mm	1" 25mm	1-1/2" 40mm	2" 50mm	2-1/2" 65mm	3" 80mm	4" 100mm	6" 150mm	8" 200mm
Face to Face	L1: RF L3: BW	4.25	4.63	5.00	6.50	8.00	8.50	9.50	11.50	16.00	19.50
Valve Open Height (H)		7.50	7.81	8.90	10.25	10.47	11.06	13.46	14.84	16.89	21.97
Handwheel Diameter (D)		3.94	3.94	5.51	7.09	7.09	8.87	8.82	11.02	13.98	15.75
Weight (lbs).		6.62	8.20	10.82	20.30	31.34	43.30	55.10	96.25	173.00	320.00

Dimensions in inches

CLASS 300

Valve Size		1/2" 15mm	3/4" 20mm	1" 25mm	1-1/2" 40mm	2" 50mm	2-1/2" 65mm	3" 80mm	4" 100mm	6" 150mm	8" 200mm
Face to Face	L1: RF L3: BW	6.00	7.00	8.00	9.00	10.50	11.50	12.50	14.00	17.50	22.00
Valve Open Height (H)		7.28	7.64	8.82	10.51	12.99	13.93	15.08	17.44	22.32	27.40
Handwheel Diameter (D)		3.94	3.94	5.51	7.09	7.09	7.87	8.84	11.02	15.75	17.72
Weight (lbs).		8.80	11.50	20.70	32.20	58.50	80.00	119.20	171.00	292.00	574.00

CAST STAINLESS STEEL SWING CHECK VALVES

STANDARD PARTS & MATERIALS

NO.	PART NAME	STAINLESS STEEL				
		TYPE CF8M	TYPE CF8	TYPE CF3M	TYPE CF3	TYPE CN7M
1	BODY	A351 CF8M	A351 CF8	A351 CF3M	A351 CF3	A351 CN7M
2	COVER	A351 CF8M	A351 CF8	A351 CF3M	A351 CF3	A351 CN7M
3	DISC	A351 CF8M	A351 CF8	A351 CF3M	A351 CF3	A351 CN7M
4	HINGE	A351 CF8M	A351 CF8	A351 CF3M	A351 CF3	A351 CN7M
5	HINGE PIN	A276 316	A276 304	A276 316	A276 304	B473
6	DISC NUT	A193 B8	A193 B8	A193 B8	A193 B8	A193 B8
7	DISC WASHER	STAINLESS STEEL	STAINLESS STEEL	STAINLESS STEEL	STAINLESS STEEL	STAINLESS STEEL
8	SPLIT PIN	A276 316	A276 304	A276 316	A276 304	B473
9	COVER BOLT	A193 B8	A193 B8	A193 B8	A193 B8	A193 B8
10	COVER NUT	A194 8	A194 8	A194 8	A194 8	A194 8
11	EYE BOLT	ASTM A181	ASTM A181	ASTM A181	ASTM A181	ASTM A181
12	GASKET	TEFLON				
13	NAMEPLATE	STAINLESS STEEL	STAINLESS STEEL	STAINLESS STEEL	STAINLESS STEEL	STAINLESS STEEL

Cast stainless steel swing valve, horizontal or vertical lines, bolted cover, integral seat designed according to API-603, ASME B16.34.

DIMENSIONS

Face to Face	ASME B16.10
End Flange	ASME B16.5
Buttweld	ASME B16.25
Rating	ASME Class 150/300

MODEL 6150 / 6300

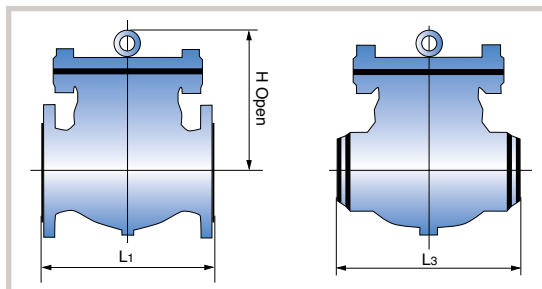

Dimensions in inches

Valve Size		1/2" 15mm	3/4" 20mm	1" 25mm	1-1/2" 40mm	2" 50mm	2-1/2" 65mm	3" 80mm	4" 100mm	6" 150mm	8" 200mm	10" 250mm	12" 300mm
Face to Face	L1: RF L3: BW	4.25	4.63	5.00	6.50	8.00	8.50	9.50	11.50	14.00	19.50	24.50	27.50
Valve Open Height (H)		3.26	3.50	4.00	4.72	5.43	6.10	6.30	7.91	9.76	11.53	12.99	13.94
Weight (lbs).		5.05	6.18	9.05	15.70	27.60	39.50	46.35	75.50	130.90	225.60	499.00	638.00

CLASS 150

Dimensions in inches

Valve Size		1/2" 15mm	3/4" 20mm	1" 25mm	1-1/2" 40mm	2" 50mm	2-1/2" 65mm	3" 80mm	4" 100mm	6" 150mm	8" 200mm	10" 250mm	12" 300mm
Face to Face	L1: RF L3: BW	5.50	6.00	8.50	9.50	10.50	11.50	12.50	14.00	17.50	21.00	24.50	28.00
Valve Open Height (H)		3.66	3.78	4.41	4.96	5.98	6.46	6.93	7.32	10.31	12.28	13.98	15.47
Weight (lbs).		7.73	9.93	22.96	32.20	39.70	79.47	88.30	152.30	234.00	379.70	498.00	638.00

CLASS 300

O-RING SEAL BLOCK & BLEED GATE VALVES

Sizes Available: 2" - 24"
 Class: 150 & 300

Design Features

The dovetail groove feature in the seat ring holds the O-Ring seal in place while allowing it to expand or contract during service and still maintains the proper compression to provide uniform sealing.

The precision ground metal to metal seats with the O-Ring feature as secondary seal provides dual seating and eliminates any media contamination.

A bleed plug is provided at position G to verify shut-off.

Fire Safe, Vapor Tight Shut-off

Should fire occur burning or damaging the O-Ring seal, metal to metal seats will provide an effective fire-safe shut-off.

Service Recommendations

GWC O-Ring Seal Block and Bleed Gate Valves are recommended for hard to hold services such as butane, kerosene, gasoline, propane, diesel oils, fuel oils, jet fuels, steam, air, natural gas, toluene, hydrogen, helium, and oxygen. Manifold tank farms, LPG areas, and airport fueling facilities provide excellent opportunities for savings with the O-Ring Seal Gate Valves. For effective double block and bleed service, the line media should be free of foreign matter and solids in suspension.

Seat Materials

Teflon is considered our standard. It is the most widely used elastomer because of its resistance to corrosive and abrasive conditions. We can also offer other materials. Seat insert materials should be specified along with actual service conditions when ordering.

Type Range Temperature Operating

Teflon (PTFE) -100° F + 400° F

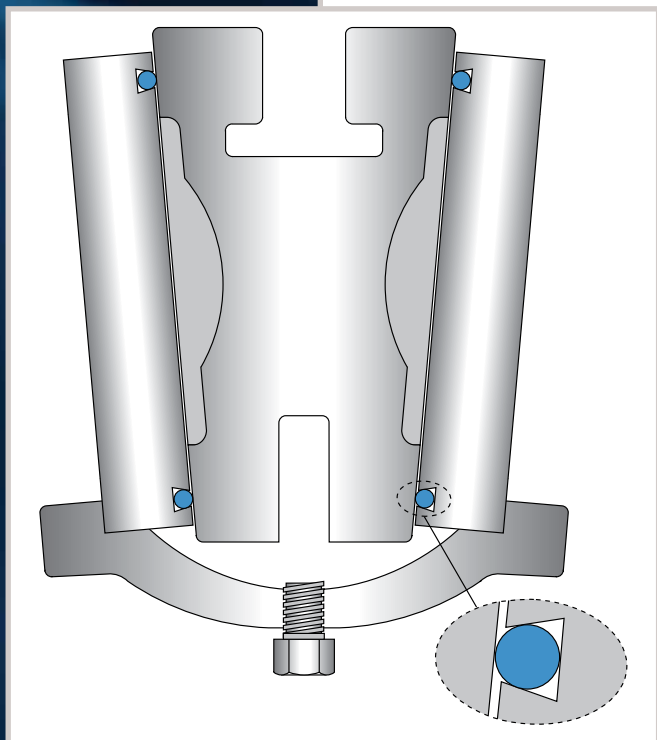
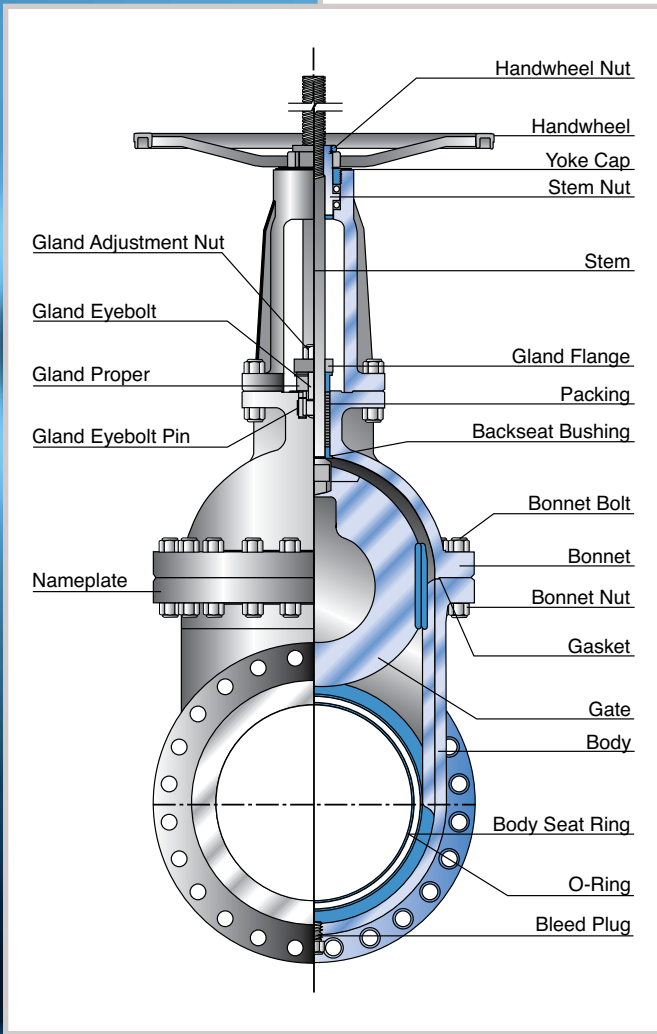

CAST STEEL CYROGENIC GATE, GLOBE & CHECK VALVES

GWC Cryogenic Valves are manufactured to the latest edition of API Standard 600 and/or 603 and tested to API Standard 598.

Application & Function

During the processes of production, transportation, storage and usage of liquefied gases, countless technical problems can be experienced. GWC's cryogenic valves are designed to assure safety and reliability under these critical conditions.

All of GWC's cryogenic valves are thoroughly cleaned and degreased. Afterwards the end ports are sealed to prevent contamination. This process is performed in an approved and designated *clean room*.

Body & Bonnet

The design of the body and bonnet is calculated to achieve the most regular distribution of stress in all directions, as well as the minimum turbulence and resistance to flow.

The extended bonnet provides a gas column which thermally isolates the stem packing and stem nut from the extreme temperatures so they remain functional. Usually the customer specifies the column length.

The body-bonnet joint is bolted using applicable ASTM specified bolting for low temperature/cryogenic conditions.

Gasket

We can supply any style of gasket required by our customer; however, we recommend gaskets that are oxygen compatible.

Closures

Gate Valves – All gates are fully guided to the seats. As standard, our valves are supplied with a stellite faced, solid flexible gate that has a tapered H cross-section. The flexible wedge is cast or machined with a circumferential groove to allow the seating surfaces to move independently and adjust to movement of the body seats.

Globe Valves – The valve is normally supplied with the plug type disc. The disc rotates freely on the stem and incorporates a differential angle from that on the seat ring. This design provides the maximum assurance of shut off, is less likely to stick in the body seat and is considered the simplest design for field repair. Bottom guided discs are available.

Check Valves – Each disc's seating surface is precision ground and mated to the seat ring for insurance of a positive shut off. The disc is bolted to the hinge arm and pinned to prevent disengagement during service.

KEL-F and other soft inserts are available upon request.

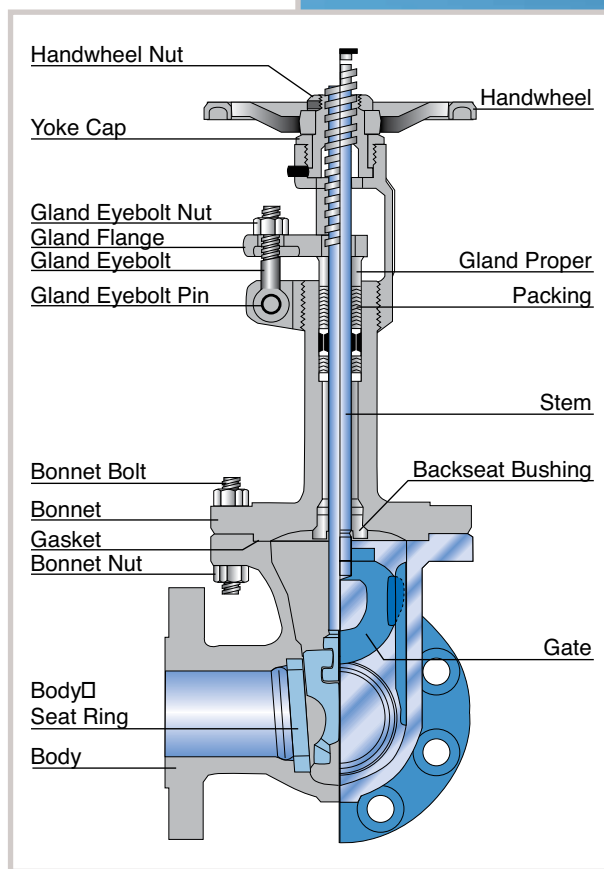

CAST STEEL CYROGENIC GATE, GLOBE & CHECK VALVES**SEAT RING**

Stellite faced seat rings are standard and provide excellent resistance to seizing and galling. KEL-F inserts are available when extremely tight shut-off is required. Our globe and check valves are supplied with KEL-F or other soft inserts as specified by the customer.

STEM

The stem connection to the wedge is a T-head design which is integral (without welding) with the stem. The T-head on NPS 8" and smaller valves are forged. The accuracy in the dimensions and finishes assure a long life with a perfect tightness in the packing area.

The stem-to-gate connection is designed to prevent the turning or the disengagement of stem from the wedge while the valve is in service.

Through calculations and extreme testing, the strength of the stem-to-gate connection has proven to exceed the strength of the stem at the root of its operating thread.

STEM PACKING

The stem packing is designed and arranged to ensure a maximum seal along the stem during operation or while at position. Our packings are NON-ASBESTOS types.

We can supply any style of packing required by our customer.

STEM NUT

The stem nut arrangement and design allows for the removal of the handwheel without allowing the stem and gate to drop into the closed position if the handwheel is removed while the valve is in the open position.

Ball bearings are provided in the stem nut arrangement of Class 150 valves from NPS 14", on Class 300 valves from NPS 12", on Class 600 valves from NPS 6", and on Class 900 and Class 1500 valves from NPS 2".

PACKING GLAND

The packing gland design is a two-piece, self-aligning type. The gland proper has a spherical head that rides within spherical joint of the gland flange. The gland proper has a shoulder, which restricts the complete entry into the stuffing box bore. This particular design assures a straight compression of the packing as the gland eyebolts are being equally adjusted, without injuring the stem.

HANDWHEELS

Handwheels are designed for easy operation and a comfortable grip. Our valves are also available with gearing, motor actuators or cylinder actuators for more demanding services.

END CONNECTIONS

Our standard production covers valves with:

- Flange ends with raised face (RF), flat face (FF) or ring type joint (RTJ) ends that conform to B16.5.
- Butt-welding (BW) ends that conform to B16.25.
- All face-to-face/end-to-end dimensions conform to B16.10.
- Other special end connections are supplied according to customer's requirements.

ACCESSORIES

Accessories such as gear operators, actuators, bypasses, locking devices, chainwheels, and many others are available to meet the customers requirements.

PRESSURE - TEMPERATURE RATINGS

ASME B16.34-2009

COLD WORKING PRESSURE, psig											
CLASS	TEMP °F	A216 WCB A105 & LF2	A352 LCC	A217 WC6 A182 F11	A217 WC9 A182 F22	A217 C5 A182 F5	A217 C12 A182 F9	A351 CF8 A182 F304	A351 CF8M A182 F316	A352 CN7M	
150	20 to 100	285	290	290	290	290	290	275	275	230	
	200	260	260	260	260	260	260	230	230	200	
	300	230	230	230	230	230	230	205	205	180	
	400	200	200	200	200	200	200	190	190	160	
	500	170	170	170	170	170	170	170	170	150	
	600	140	140	140	140	140	140	140	140	140	
	650	125	125	125	125	125	125	125	125		
	700	110	110	110	110	110	110	110	110		
	750	95	95	95	95	95	95	95	95		
	800	80	80	80	80	80	80	80	80		
	850	65	65	65	65	65	65	65	65		
	900	50	50	50	50	50	50	50	50		
	950	35	35	35	35	35	35	35	35		
	1000	20	20	20	20	20	20	20	20		
	1050				20 (a)	20 (a)	20 (a)	20 (a)	20(a)	20(a)	
	1100				20 (a)	20 (a)	20 (a)	20 (a)	20(a)	20(a)	
	1150				20 (a)	20 (a)	20 (a)	20 (a)	20(a)	20(a)	
	1200				15 (a)	15 (a)	15 (a)	20 (a)	20(a)	20(a)	
1250								20(a)	20(a)		
1300								20(a)	20(a)		
1350								20(a)	20(a)		
1400								20(a)	20(a)		
1450								20(a)	20(a)		
1500								15(a)	15(a)		
CLASS	TEMP °F	A216 WCB A105 & LF2	A352 LCC	A217 WC6 A182 F11	A217 WC9 A182 F22	A217 C5 A182 F5	A217 C12 A182 F9	A351 CF8 A182 F304	A351 CF8M A182 F316	A352 CN7M	
300	-20 to 100	740	750	750	750	750	750	720	720	600	
	200	680	750	750	750	750	750	600	620	520	
	300	655	730	720	730	730	730	540	560	465	
	400	635	705	695	705	705	705	495	515	420	
	500	605	665	665	665	665	665	465	480	390	
	600	570	605	605	605	605	605	440	450	360	
	650	550	590	590	590	590	590	430	440		
	700	530	555	570	570	570	570	420	435		
	750	505	505	530	530	530	530	415	425		
	800	410	410	510	510	510	510	405	420		
	850	320	320	485	485	485	485	395	420		
	900	230	225	450	450	375	450	390	415		
	950	135	135	320	385	275	375	380	385		
	1000	85	85	215	265	200	255	355	365		
	1050			145	175	145	170	325	360		
	1100			95	110	100	115	255	305		
	1150			65	70	60	75	205	235		
	1200			40	40	35	50	165	185		
1250							135	145			
1300							115	115			
1350							95	95			
1400							75	75			
1450							60	60			
1500							40	40			

(a) – Permissible, but not recommended for prolonged usage

PRESSURE - TEMPERATURE RATINGS

ASME B16.34-2009

COLD WORKING PRESSURE, psig										
CLASS	TEMP °F	A216 WCB A105 & LF2	A352 LCC	A217 WC6 A182 F11	A217 WC9 A182 F22	A217 C5 A182 F5	A217 C12 A182 F9	A351 CF8 A182 F304	A351 CF8M A182 F316	A352 CN7M
600	-20 to 100	1480	1500	1500	1500	1500	1500	1440	1440	1200
	200	1360	1500	1500	1500	1500	1500	1200	1240	1035
	300	1310	1455	1445	1455	1455	1455	1075	1120	930
	400	1265	1405	1385	1410	1410	1410	995	1025	845
	500	1205	1330	1330	1330	1330	1330	930	955	780
	600	1135	1210	1210	1210	1210	1210	885	900	720
	650	1100	1175	1175	1175	1175	1175	865	885	
	700	1060	1110	1135	1135	1135	1135	845	870	
	750	1015	1015	1065	1065	1065	1065	825	855	
	800	825	825	1015	1015	1015	1015	810	845	
	850	640	640	975	975	975	975	790	835	
	900	460	445	900	900	745	900	780	830	
	950	275	275	640	755	550	755	765	775	
	1000	170	170	430	535	400	505	710	725	
	1050			290	350	290	345	650	720	
	1100			190	220	200	225	515	610	
	1150			130	135	125	150	410	475	
	1200			80	80	70	105	330	370	
	1250							265	295	
	1300							225	235	
1350							185	190		
1400							150	150		
1450							115	115		
1500							85	85		
CLASS	TEMP °F	A216 WCB A105 & LF2	A352 LCC	A217 WC6 A182 F11	A217 WC9 A182 F22	A217 C5 A182 F5	A217 C12 A182 F9	A351 CF8 A182 F304	A351 CF8M A182 F316	A352 CN7M
900	-20 to 100	2200	2250	2250	2250	2250	2250	2160	2160	1800
	200	2035	2250	2250	2250	2250	2250	1800	1860	1555
	300	1965	2185	2165	2185	2185	2185	1615	1680	1395
	400	1900	2110	2080	2115	2115	2115	1490	1540	1265
	500	1810	1995	1995	1995	1995	1995	1395	1435	1165
	600	1705	1815	1815	1815	1815	1815	1325	1355	1080
	650	1650	1765	1765	1765	1765	1765	1295	1325	
	700	1590	1665	1705	1705	1705	1705	1265	1305	
	750	1520	1520	1595	1595	1595	1595	1240	1280	
	800	1235	1235	1525	1525	1525	1525	1215	1265	
	850	955	955	1460	1460	1460	1460	1190	1255	
	900	690	670	1350	1350	1120	1350	1165	1245	
	950	410	410	955	1160	825	1130	1145	1160	
	1000	255	255	650	800	595	760	1065	1090	
	1050			430	525	430	515	975	1080	
	1100			290	330	300	340	770	915	
	1150			195	205	185	225	615	710	
	1200			125	125	105	155	495	555	
	1250							400	440	
	1300							340	350	
1350							280	290		
1400							225	225		
1450							175	175		
1500							125	125		

(a) – Permissible, but not recommended for prolonged usage

PRESSURE - TEMPERATURE RATINGS

ASME B16.34-2009

COLD WORKING PRESSURE, psig										
CLASS	TEMP °F	A216 WCB A105 & LF2	A352 LCC	A217 WC6 A182 F11	A217 WC9 A182 F22	A217 C5 A182 F5	A217 C12 A182 F9	A351 CF8 A182 F304	A351 CF8M A182 F316	A352 CN7M
1500	-20 to 100	3705	3750	3750	3750	3750	3750	3600	3600	3000
	200	3395	3750	3750	3750	3750	3750	3000	3095	3590
	300	3270	3640	3610	3640	3640	3640	3640	2690	2795
	400	3170	3520	3465	3530	3530	3530	3530	2485	2570
	500	3015	3325	3325	3325	3325	3325	3325	2330	2390
	600	2840	3025	3025	3025	3025	3025	3025	2210	2255
	650	2745	2940	2940	2940	2940	2940	2940	2160	2210
	700	2665	2775	2840	2840	2840	2840	2840	2110	2170
	750	2535	2535	2660	2660	2660	2660	2660	2065	2135
	800	2055	2055	2540	2540	2540	2540	2540	2030	2110
	850	1595	1595	2435	2435	2435	2435	2435	1980	2090
	900	1150	1115	2245	2245	1870	2245	1945	2075	
	950	685	685	1595	1930	1370	1885	1910	1930	
	1000	430	430	1080	1335	995	1270	1770	1820	
	1050			720	875	720	855	1630	1800	
	1100			480	550	495	565	1285	1525	
	1150			325	345	310	375	1030	1185	
	1200			205	205	170	255	825	925	
1250							670	735		
1300							565	585		
1350							465	480		
1400							380	380		
1450							290	290		
1500							205	205		
CLASS	TEMP °F	A216 WCB A105 & LF2	A352 LCC	A217 WC6 A182 F11	A217 WC9 A182 F22	A217 C5 A182 F5	A217 C12 A182 F9	A351 CF8 A182 F304	A351 CF8M A182 F316	A352 CN7M
2500	-20 to 100	6170	6250	6250	6250	6250	6250	6000	6000	5000
	200	5655	6250	6250	6250	6250	6250	5000	5160	4320
	300	5450	6070	6015	6070	6070	6070	4480	4660	3880
	400	2280	5865	5775	5880	5880	5880	4140	4280	3520
	500	5025	5540	5540	5540	5540	5540	3880	3980	3240
	600	4730	5040	5040	5040	5040	5040	3680	3760	3000
	650	4575	4905	4905	4905	4905	4905	3600	3680	
	700	4425	4630	4730	4730	4730	4730	3520	3620	
	750	4230	4230	4430	4430	4430	4430	3440	3560	
	800	3430	3430	4230	4230	4230	4230	3380	3520	
	850	2655	2655	4060	4060	4060	4060	3300	3480	
	900	1915	1855	3745	3745	3115	3745	3240	3460	
	950	1145	1145	2655	3220	2285	3145	3180	3220	
	1000	715	715	1800	2230	1655	2115	2950	3030	
	1050			1200	1455	1200	1430	2715	3000	
	1100			800	915	830	945	2145	2545	
	1150			545	570	515	630	1715	1970	
	1200			345	345	285	430	1370	1545	
1250							1115	1230		
1300							945	970		
1350							770	800		
1400							630	630		
1450							485	485		
1500							345	345		

(a) – Permissible, but not recommended for prolonged usage



**WORLDWIDE
HEADQUARTERS**

GWC Italia S.p.A.

Via A. Grandi, 5
20056 Trezzo Sull'Adda
Milano, Italy
ph: 39-02-86882941
fax: 39-02-86882942

USA HEADQUARTERS

GWC Italia

7600 District Blvd.
Bakersfield, CA 93313 USA
ph: 661-834-1775
fax: 661-834-2072

www.gwcitalia.com